

BULLETIN NO. 202  
ISSUE 1  
APRIL, 1948

# TELETYPE

## PRINTING TELEGRAPH SYSTEMS

### DESCRIPTION

#### REPERFORATOR TRANSMITTER (MODEL 14)

FRXD9 AND FRXDIO  
TYPE PALLET ARRANGEMENT 201  
MOTOR ARRANGEMENTS EL AND EN



CORPORATION  
SUBSIDIARY OF  
*Western Electric Company*  
CHICAGO, U.S.A.

BULLETIN NO. 202  
ISSUE I  
APRIL, 1948

# TELETYPE

## PRINTING TELEGRAPH SYSTEMS

### DESCRIPTION

#### REPERFORATOR TRANSMITTER (MODEL 14)

FRXD9 AND FRXDIO  
TYPE PALLET ARRANGEMENT 20I  
MOTOR ARRANGEMENTS EL AND EN



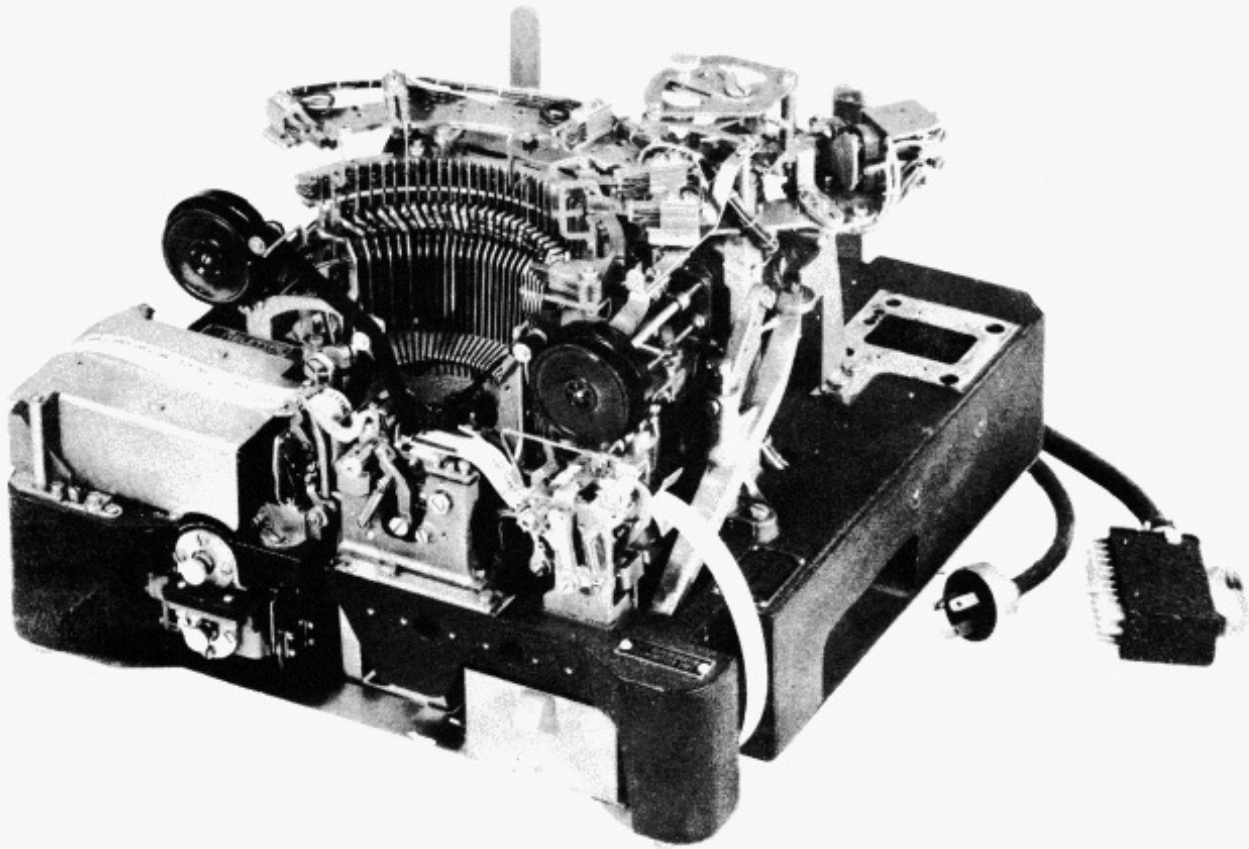

REPERFORATOR TRANSMITTER  
FRXD 9

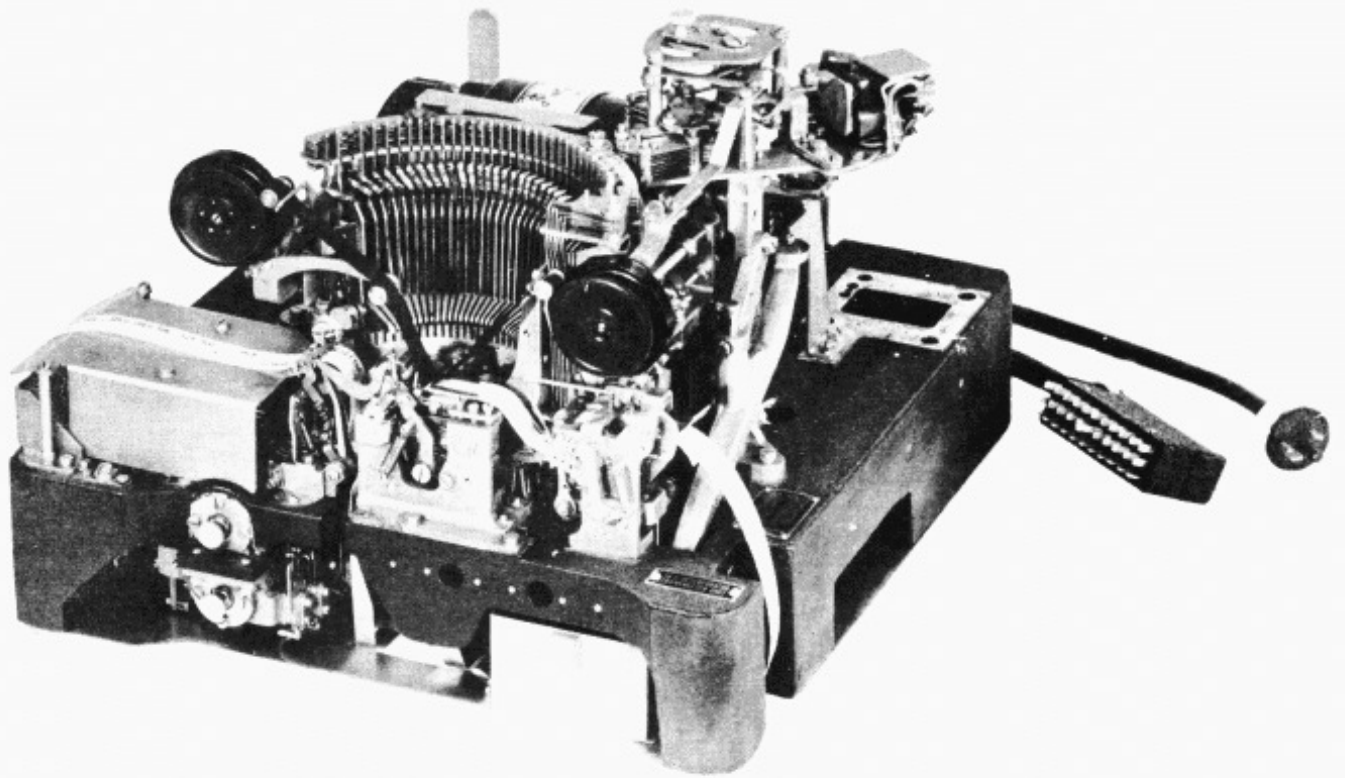

REPERFORATOR TRANSMITTER  
FRXD 10

## TABLE OF CONTENTS

<u>Paragraph</u>	<u>Page</u>
SECTION I DESCRIPTION	
1. General -----	1-1
2. Typing and Reperforating Mechanism -----	1-1
a. General -----	1-1
b. Main-Shaft Assembly -----	1-1
c. Range-Finder Assembly -----	1-1
d. Selector Assembly -----	1-2
e. Tape Feed-Out Mechanism -----	1-3
f. Clutch Throwout Lever -----	1-3
g. Printing -----	1-3
h. Code-Bar Locking Lever -----	1-4
i. Code-Punch Mechanism -----	1-4
j. Feed-Hole Prepunch Mechanism -----	1-4
k. Overlap -----	1-5
m. Ribbon Feeding -----	1-5
n. Ribbon Reverse -----	1-5
o. Upper and Lower Case Shift Mechanism -----	1-5
p. Motor Units -----	1-6
q. Synchronism -----	1-6
r. Orientation -----	1-6
3. Pivoted Tape Transmitter and Distributor Mechanism -----	1-7
a. General -----	1-7
b. Pivoted Transmitter Yoke -----	1-7
c. Sensing-Shaft Magnet Contact -----	1-7
d. Tape Depressor (Tape Operating Bail) -----	1-7
e. Tape Feeding Mechanism -----	1-7
f. Signal Transfer and Storage Mechanism -----	1-8
g. Signal Retransmitter -----	1-9
4. Contact Assemblies and Other Features -----	1-10
a. Switching Contacts (FRXD9 Only) -----	1-10
b. Universal Contacts -----	1-10
c. Tape-Feed-Indicator Contact -----	1-10
d. Miscellaneous Features -----	1-10

## SECTION I

## DESCRIPTION

## 1. GENERAL

a. The Reperforator Transmitter Distributor is a motor driven mechanism which combines in a single unit the functions of a typing reperforator and a tape transmitter distributor.

b. The unit provides a fully automatic mechanism in which the perforated tape may be stored in the form of a loop to accommodate any delay in transmission, or in which all the combinations in the tape up to and including the last character perforated may be immediately transmitted. This is accomplished by means of a pivoted tape transmitter which moves along the tape, as it becomes taut, until it reaches a position one character space (.100") away from the point at which code perforation takes place. Standard 11/16" wide perforator tape is used.

c. The FRXD9 and FRXD10 reperforator transmitter distributors have the same mechanical features with the exception of the pull-bar-operated switching contacts which are provided on the FRXD9 only.

d. The reperforator transmitter distributor receives and retransmits signal combinations of the start-stop five-unit code (Figure 3). This code utilizes five selecting elements in combinations of current and no-current intervals to form thirty-two code combinations. In order to maintain synchronism between transmitting and receiving units, each group of five selecting intervals is preceded by a START interval and followed by a STOP interval. Intervals during which current is transmitted are designated as MARKING intervals and those during which no current is transmitted are designated as SPACING intervals.

## 2. TYPING AND REPERFORATING MECHANISM

## a. GENERAL

(1) A method of tape perforating known as chadless perforating is used to permit both printed and perforated characters to occupy the same portion of the tape. The punchings, or chads, are not completely severed from the tape but remain attached to it at their leading edges so as to form lids over the holes. The printed characters are legible because the perforating does not eliminate any portion of

the tape.

(2) Typing and perforating occur simultaneously, but due to the fact that the platen is to the right of the perforator die block, characters are typed at the right of their respective perforations. The separation between the printed character and its associated perforation is six character spaces. This separation must be taken into account when tearing message tapes from the unit or in cutting the tape. When the tape is to be used for transmission by means of an external transmitter distributor, the end of the tape should include all of the printed characters in the message and the first printed character of the message must be preceded by at least six sets of code perforations in order to transmit the entire message.

(3) When a message tape is inserted in the tape guide of an external transmitter distributor, and the printed symbol of the character to be transmitted is positioned opposite the tape locating mark impressed in the tape guide, the code perforation for that character will be over the tape sensing pins in position for transmission. Under this condition, if the tape retainer of the transmitter distributor is fastened over the tape, the tape locating mark will be covered, but the printed character will be visible immediately to the right of the tape retainer.

## b. MAIN-SHAFT ASSEMBLY

Motion for the setting up of selections and for the performance of all functions is derived from cams mounted on the main shaft (Figure 4). This shaft is driven by a motor through the medium of a pinion and worm gear. The selector cam sleeve is fitted over the end of the main shaft and is driven through the medium of a friction clutch formed by two pairs of steel discs separated by felt washers. The main-bail cam (which provides motion for all other functions of the receiving unit except selecting, perforating and spacing) and the punch-arm cam are assembled in one unit and are driven by a positive clutch consisting of a driving member and a driven member.

## c. RANGE-FINDER ASSEMBLY

(1) The range-finder assembly (Figure 6)

consists essentially of a mounting plate with graduated scale, an index arm, stop lever, trip latch, bell crank and trip-latch plunger.

(2) The angular position of the stop lever is controlled by the index arm so as to stop the selector cam sleeve at the required position. The trip latch, under tension from a compression spring, latches the stop lever and consequently holds the selector cam sleeve in the stop position.

(3) Release of the stop lever and selector cam sleeve occurs when the selector-magnet armature, under tension of its spring, impresses the trip-off screw located on the upper extension of the armature, against the trip-latch plunger. Movement of the plunger tilts the bell crank and raises the trip latch clear of the stop lever.

#### d. SELECTOR ASSEMBLY

(1) The selector assembly (Figure 5), located below the range finger, consists essentially of a two-coil selector magnet, armature, selector arm, locking lever, and five each of selector levers, swords and T levers.

(2) The armature pivots on the selector-magnet bracket, extends above the selector arm, and, under tension of the armature spring, rides the armature cam on the selector cam sleeve. This cam impresses the armature against the core of the magnet in timed relation to the code impulses. If the magnet is not energized when the armature is presented, the armature is immediately retracted by its spring; if energized, the armature is held by the magnet for the duration of the marking impulse. The armature carries two adjusting screws; the trip-off screw on an upper extension (Figure 6) and a selector-arm operating screw (Figure 5) on a lower extension. A selector-arm spring links the selector arm to the armature and tends to hold the selector arm against the head of the selector-arm adjusting screw.

(3) The selector arm pivots on a bracket located in front of the magnet bracket. Vertical extensions of the selector arm are positioned so as to present a blocking surface to the arms of the five swords. A locking wedge (Figure 5) with stud extending downward, is attached to the forward end of the selector arm. A stop detent, into which the stud projects, limits the travel of the selector arm and tends to hold it to either side.

(4) The locking wedge is acted upon by a locking lever, the forward extension of which locks the selector arm to right or left as

the locking lever drops into each indent of the locking cam (second from the top) on the cam sleeve. The locking lever rides its cam under tension from the locking-lever spring.

(5) The five selector levers and the swords, which are coupled to them by floating pivots, lie between separator plates. The swords are under slight pressure from the tongues of these plates. The selector levers pivot on a single post and under tension of their springs impress the tips of the swords against the arms of the T levers. The T levers also lie between the separator plates and pivot on a single post. Five cam teeth on the cam sleeve actuate the selector levers in sequence, causing the swords to be withdrawn from the T levers for repositioning by the selector arm.

(6) Selection of a character is accomplished as follows:

(a) From an idling condition, under which the main shaft rotates with the magnet energized and with the selector cam sleeve and the punch-arm cam stationary, the selecting cycle is initiated by the reception of the start impulse (no current - spacing). The armature spring retracts the armature and with it the selector arm, to the spacing side. Pressure on the trip-latch plunger by the trip-off screw causes release of the selector cam sleeve by the range-finder mechanism.

(b) During rotation of the sleeve, the armature will be impressed on the core of the magnet each time the armature rises from an indent in its cam. Assuming that code impulses representing the Y character are being applied to the magnet, the first will be MARKING (current). This impulse will hold the armature attracted on the first presentation. The selector arm, co-active with the armature, will likewise be in its MARKING position where it will be immediately locked by the locking lever as it drops from the high part of its cam. The No. 1 selector lever, riding to the peak of its cam, will shift the No. 1 sword in the direction of the selector arm. Assuming that the tip of the sword is in the SPACING position (tip toward the right as viewed from the front of the unit), its right arm will be blocked by the selector arm, causing the sword tip to shift to MARKING (left). As No. 1 selector lever drops from the peak of the cam, the No. 1 sword will be impressed against the left arm of No. 1 T lever, causing it to rotate counter-clockwise (as viewed from above) due to tension exerted by the selector-lever spring. If the tip of the No. 1 sword is in the MARKING position when responding to the selector action described in the foregoing, it will not require

repositioning and will merely perform a simple motion without contacting the selector arm. The armature will be impressed on the magnet core in time with No. 2 code impulse, but since this impulse is SPACING (no current), the armature and selector arm will immediately return to SPACING in time for the selector arm to be locked in that position by the locking lever. No. 2 sword will move toward the selector arm as its associated selector lever is actuated, and its left arm will be blocked by the selector arm, provided its tip is in the MARKING position (left). The tip of the sword will be thrown to spacing where it will impart clockwise motion to No. 2 T lever as No. 2 selector lever drops off the peak of its cam.

(c) Corresponding actions accompany the reception of the third impulse MARKING, fourth SPACING, and fifth MARKING, for completion of the "Y" character selection. Subsequently, Nos. 3 and 5 T levers will assume positions corresponding to No. 1. while No. 4 will correspond to No. 2.

(d) Immediately following the fifth impulse, the armature will again be presented to the magnet where it will be retained by the stop impulse (MARKING). During this interval, no locking action will be applied to the selector arm, since, at that time, the locking lever will be riding the long high portion of its cam. During the stop interval, the stop arm of the selector cam sleeve will come to rest against the stop lever on the range finder, thus completing the selecting cycle.

(e) From the above, it is apparent that the code impulses are utilized to direct the tips of the swords relative to the arms of the T levers, and that the motivating force applied to the T levers derives from the tension of the selector-lever springs.

#### e. TAPE FEED-OUT MECHANISM

(1) The tape feed-out mechanism is used for the purpose of starting a roll of tape through the prepunch and perforating mechanisms or to prepare a series of rubouts (when the line is idle and the selector magnet is energized).

(2) The tape feed-out mechanism is mounted on top of the selecting unit and consists of a tape feed-out lever, a release rod, a spring, and mounting screws (Figures 1 and 6). It provides a means of releasing the trip latch of the range-finder assembly manually freeing the selector-clutch cam sleeve to rotate while the selector magnet is energized. The release

lever is mounted on a range-finder mounting post of the selector plate and pivots at this point. The lever has two arms, one projecting to a position to engage the bell crank of the range-finder assembly, the other mounted to the clutch release rod. The release rod is mounted to a bracket and a post by two elongated holes so that it may be moved back and forth. A spring is attached to the rod to hold it in a forward position.

(3) When pressure is applied to the release rod of the tape-feed-out mechanism, the release lever turns slightly in a counterclockwise direction causing one of the tape-out-lever arms to actuate the bell crank of the range finder and release the trip latch. The selector-clutch cam sleeve is then free to rotate as long as the lever is pressed. As soon as pressure is removed from the release rod, its spring pulls the mechanism out of engagement with the range-finder bell crank and the selector-clutch cam sleeve is stopped by the trip latch re-engaging the stop pawl of the range scale. When this mechanism is used the LETTERS code combination is perforated in the tape, since the magnet is energized during the complete revolution of the selector cam sleeve.

#### f. CLUTCH THROWOUT LEVER

During the positioning of the No. 5 selector sword, the sixth cam of the selector cam sleeve disengages the clutch stop arm from the driven clutch member (Figure 4). The main-shaft clutch spring then moves the clutch members into engagement with each other and causes the main-bail cam and punch-arm cam to rotate. Rotation continues until transmission ceases. Then the clutch stop arm of the clutch throwout lever engages the cam surface of the projection on the driven clutch member and cams it out of mesh with the driving clutch member. Thus it may be seen that immediately after the completion of a selecting cycle the main-bail cam and punch-arm cam will be permitted to rotate one revolution to perform the operations required for printing and perforating, respectively.

#### g. PRINTING

(1) The power for the performance of printing and other functions (except selecting, perforating and spacing) is derived from the main bail which is operated by the main-bail cam through the medium of a bell crank, lever, and plunger (Figure 7). In the normal stop position, the main-bail bell-crank roller is on the high part of its cam as shown in Figure 7. In this position the main bail engages the camming surface of the pull bars, pushing them forward away from the code bars so that



the code bars can be positioned by the selector mechanism. When the main-bail cam rotates, the main-bail bell-crank roller rides down the slope of the main-bail cam and permits the main-bail spring to raise the bail through the medium of the main-bail plunger and the main-bail lever.

(2) As the main bail moves upward, the pull-bar springs move the pull bars toward the code bars. The unselected pull bars are blocked by the code bars but the selected pull bar moves into the path set up by the alignment of notches in the code bars, and a hooklike projection of the rear edge of the selected pull bar is engaged by the main bail, causing the pull bar to be raised. The rack and gear connection between the pull bar and type bar causes the type bar to rotate about its pivot toward the platen. As the pull bar is moved upward, the sloping surface of the rear projection on the pull bar strikes a stripper plate and causes the pull bar to be disengaged from the main bail shortly before the type bar reaches the platen. Momentum carries the type bar the remaining distance to the platen. Further rotation of the main-bail cam restores the main bail and pull bars to their normal stop position.

(3) Letter characters are printed near the top of the tape and figure characters are printed near the bottom of the tape.

#### h. CODE-BAR LOCKING LEVER

The code bars are locked in position after each selection by the code-bar locking lever, located in the extreme right-hand slot of the pull-bar guide (Figure 9A). The locking lever is brought into engagement with "V" shaped notches in the code bars by a spring during the early part of the upward stroke of the main bail. It is cammed out of engagement with the notches by the main bail as the main bail nears the end of its downward stroke (Figure 7). When the code bars are not engaged by the locking lever (Figure 9B), they are free to be positioned by the selector swords and T levers (Figure 5).

#### i. CODE-PUNCH MECHANISM

(1) Power for perforating the tape is derived from the punch-arm cam on the main shaft which actuates the code punches by means of the punch arm through the medium of the punch-arm bracket, punch-arm link, punch bail, and punch selector fingers (Figure 10). The punch selector fingers are positioned by the punch bell-crank springs so that the selection set up in the code bars will be perforated in

the tape. The positioning of the punch selector fingers takes place early in the upward stroke of the main bail. The motion of the code-bar locking lever is utilized to operate the code-bar bell cranks which move toward the code bars with the locking levers (Figure 9A and B). If a code bar has been positioned to the right, the motion of the associated code-bar bell crank will be blocked by the code bar as the code-bar locking lever moves toward the code bars, and the punch selector finger will remain in position to engage the punch as shown in Figure 10. If the code bar has been positioned to the left, the code-bar bell crank will be free to follow the code-bar locking lever, and the train of linkage between the code-bar bell crank and the punch bell crank will cause the punch bell crank to be turned in a clockwise direction, thereby moving the punch selector finger to the right in a position to prevent engagement with the punch.

(2) Shortly after the punch selector fingers have been positioned, the punch-arm cam rotates the punch bail through the medium of the punch-arm bracket and the punch-arm link. As the punch-arm cam rotates, the selector fingers which are in line with the punches raise the punches to perforate the tape. A feed pawl attached to the punch bail rotates the feed roll after each code combination is perforated and advances the tape for the next combination to be perforated (Figure 10).

#### j. FEED-HOLE PREPUNCH MECHANISM

In order to permit the last character combination perforated in the tape to be sensed at a point .100" from the code punches, the feed holes must be perforated in the tape before it reaches the code punches. This is accomplished by means of a prepunch mechanism. This mechanism consists of a lower bail, an upper bail, a feed pawl, a feed-roll assembly, a tape tension lever, a feed-hole punch, and a detent lever with a roller (Figure 11). The mechanism is operated with each revolution of the punch-arm cam through the medium of the punch arm and the punch-arm link. The parts are so assembled and adjusted that when the lower extension of the lower bail is moved to the left by the punch-arm link, the left end of the upper bail moves downward and drives the feed-hole punch through the tape in the die block. At the time this motion takes place the feed pawl moves upward and engages a higher tooth in the feed-roll ratchet. When the lower extension of the lower bail moves to the right, the reverse motion of the upper bail and the feed pawl takes place. The feed-hole punch withdraws from the tape just before the feed pawl rotates the feed roll by engaging

a tooth on its ratchet during its downward movement. Simultaneously with the above action, the detent roller rides over a tooth on the star wheel of the feed-roll assembly to insure even spacing of the feed-hole perforations. Since the feed hole punch is located several feed hole spaces to the right of the feed roll it is necessary to assist the mechanism manually, when inserting tape, until properly spaced feed holes reach the feed roll. This may be done by applying a slight pressure to the tape tension lever so that the feed roll grips the tape.

#### k. OVERLAP

In summarizing the selecting, printing, and perforating operations described in the foregoing, it should be noted that the selecting cycle is followed immediately by the operating cycle. Near the end of the selecting cam sleeve revolution, the sixth cam trips the clutch throwout lever and allows the main-bail cam and punch-arm cam to make one revolution. Thus it may be seen that the printing of a character or the operation of a function requires time equivalent to both a selecting and an operating cycle. However, the selection of the next character may be made at the same time that an operating cycle is taking place. This arrangement is known as overlap and is used to facilitate printer operation at high speeds. Without this feature, it would be necessary to allow time for operation after each selection.

#### m. RIBBON FEEDING

The ribbon feed lever is operated by an indent in the main-bail plunger. Attached to the upper end of the ribbon feed lever is the ribbon feed pawl which engages with the teeth on the ribbon feed ratchet. With each operation of the main bail, the ratchet is rotated a slight amount. This motion is carried through either one or two bevel gears on the ribbon spool shafts and causes one of the ribbon spools to revolve (Figures 12 and 13).

#### n. RIBBON REVERSE

Assuming that the ribbon is being wound on the left-hand spool and is almost unwound from the right-hand spool, an eyelet which is fastened to the ribbon engages and moves the right-hand ribbon reverse arm. This arm moves the right-hand ribbon reverse pawl into the path of the ribbon reverse bail (Figure 13). As the bail moves downward it engages the ribbon reverse pawl and shifts the ribbon feed shaft (Figure 14) from the left-hand ribbon feed bevel gears to the right-hand bevel gears.

The ribbon then becomes wound on the right-hand spool. The reversing operation takes place in a similar manner on the left-hand side of the assembly when the eyelet near the left end of the ribbon engages with the left-hand ribbon reverse arm.

#### o. UPPER AND LOWER CASE SHIFT MECHANISM

(1) The platen consists of a plug of composition material about 1/4" in diameter mounted on a steel bar about 3/8" square and about 2" long. This assembly fits on the platen frame which is mounted so that it can be shifted back and forth on shafts in the platen-shift bracket (Figure 15).

(2) To print letters when the platen is in the FIGURES position the LETTERS pull bar is selected. As the main bail moves upward it raises the LETTERS pull bar and a horizontal projection at the lower end of the pull bar engages the shift latch (Figure 16) and turns it in a clockwise direction. This latch which engages a notch on the shift bail (Figures 15 and 16) moves out of engagement with its notch and frees the shift bail to be turned counter-clockwise on its axis by tension of its spring. As this bail turns, an extension arm at the upper side of the bail engages the platen frame and moves it toward the rear of the machine until it is latched by the shift lever (Figure 17). In this position the platen supports the tape opposite the letters on the type pallets.

(3) Engaging the rear extension of the shift bail is an intermediate bail which is turned clockwise by the foregoing action of the shift bail. The intermediate-bail adjusting screw at the rear end of the intermediate bail is then positioned above the lowest travel of the main-bail-plunger extension bracket (Figure 15). All this action takes place during the upward movement of the main-bail plunger. When the main-bail plunger moves downward again, the plunger extension strikes the intermediate-bail adjusting screw and drives it downward to reset this chain of linkage and restore the shift latch to its latched position in the notch of the shift bail.

#### NOTE

The foregoing action also takes place when the SPACE selection is made if the machine is equipped with a space pull bar.

(4) To print figures when the platen is in the LETTERS position, the FIGURES pull bar is selected (Figure 17). As the main bail

moves upward, it lifts the FIGURES pull bar. A horizontal projection at its lower extremity unlatches the shift lever from the platen frame and permits the platen frame spring to move the platen frame to the FIGURES (forward) position against the FIGURES stop screw (Figure 15). In this position, the platen supports the tape opposite the figures on the type pallets.

p. MOTOR UNITS

(1) Synchronous motors (110 volt 60 cycle) are furnished with the FRXD9 and FRXD10. However, 110 volt 50 cycle synchronous motors, 110 volt 60 cycle series, and 110 volt D.C. shunt-wound motors are also available for use on this apparatus.

(2) A resistor unit is connected in series with the armature of D.C. shunt-wound motors and in series with both field and armature of series-wound motors. The resistor unit consists of appropriate elements which are used in parallel for the series-wound motor and in series for the shunt-wound motor. The contact of a governor assembly shunts the resistor elements.

(3) The governor assembly (Figure 18) is mounted on the motor shaft and consists essentially of a contact, contact spring, speed adjusting spring, and adjusting wheel. The resistance is shunted by the contact until the motor reaches a speed at which centrifugal force overcomes the contact spring tension and opens the contact. Alternate opening and closing of the contact causes the resistor elements to hold the motor to the required speed in accordance with the contact spring tension as regulated by the speed adjusting wheel.

(4) The motor is equipped with a target having black spots on a white background. A speed indicator (tuning fork with shutters attached to the ends of the tines) is used to visually check the motor speed. With a properly adjusted spring tension, the spots on the target will appear stationary, when observed through the shutters of the vibrating fork.

q. SYNCHRONISM

(1) In order that the signals sent out by the transmitting station may be interpreted correctly by the receiving units, it is necessary to keep the receiving units in synchronism with the transmitted signals. Synchronism is maintained by having the receiving selector cam sleeve rotate faster than the transmitting cam sleeve and by use of the start and stop

impulses in the following manner:

(2) The reception of the start impulse starts the selector cam sleeve on the receiving unit revolving. At that instant, the selector cam sleeve is in unison with the transmitting cam sleeve. The selector cam sleeve is so constructed that the distance traveled from the position where the cam sleeve starts to move a selector lever to the position where it starts to move the next selector lever is greater than the distance traveled by the transmitting cam sleeve, during the same interval; but since the selector cam sleeve travels faster, it reaches its second position at the same time the transmitting cam sleeve reaches its second position.

(3) The selector cam sleeve completes its revolution before the transmitting cam sleeve, but the transmitting cam sleeve sends out the stop impulse which stops the selector cam sleeve until the transmitting cam sleeve again sends out the start impulse. Usually the selector cam sleeve is one-seventh faster than the transmitting cam sleeve, and the selector cam sleeve is at rest one-seventh of the transmission time. If the speed of the selector cam sleeve is faster or slower than the proper speed, the cam remains at rest more or less, as the case may be. Of course, there may be a slight error in the relative position of the selector cam sleeve in the various positions, but the mechanism is so constructed as to compensate for this and, due to the fact that the selector cam sleeve starts each revolution simultaneously with the transmitting cam sleeve, this error does not become accumulative.

r. ORIENTATION

(1) In order to synchronize the action of the selector mechanism with that of the transmitting mechanism and to utilize the receiving margin of the selector to the best advantage, it is necessary to locate the starting point of the selector cam sleeve at the most favorable angle. This is accomplished by positioning the index arm of the range finder.

(2) When available, a signal-distortion test set should be used for orienting the range finder. The index arm, in its final setting, should be at the optimum position for bias in accordance with procedures outlined in the Teletype distortion distributor bulletin applying to the test set.

(3) When a signal-distortion test set is not available, the orientation range may be determined while receiving the characters

"RY." The index arm should be moved in one direction until errors appear in the perforated tape and then retracted slowly until the errors disappear. After noting this position, the index arm should be moved toward the opposite end of the scale and the other limit determined in a similar manner. The final setting should be midway between the determined limits.

### 3. PIVOTED TAPE TRANSMITTER AND DISTRIBUTOR MECHANISM

#### a. GENERAL

The pivoted tape transmitter and distributor mechanism consists essentially of a tape-sensing and a tape-feeding mechanism, a transfer mechanism, a set of transmitting contacts, a set of distributor contacts, a sensing cam-shaft assembly and a distributor cam-shaft assembly. Each of these shafts get their power from the motor through the medium of the main shaft and the subshaft assembly.

#### b. PIVOTED TRANSMITTER YOKE

The tape-sensing and tape-feeding mechanisms are arranged so that the portions of these mechanisms that feed and sense the tape are mounted on a pivoted transmitter yoke (Figure 2). This yoke is moved toward the perforator die block by the tape-feeding mechanism which pulls it along the tape so that the tape can be sensed up to and including the last combination perforated. Also this yoke can be moved away from the perforator die block by the perforated tape (until it rests against its backstop) to permit the tape to move downward into a storage compartment or form a loop between the perforator die block and the yoke.

#### c. SENSING-SHAFT MAGNET CONTACT

(1) This contact is located directly under the rear of the perforating die block and is operated by the pivoting motion of an extension on the rear of the transmitter yoke. Its function is to make and break a circuit to the sensing-shaft magnet. As the tape is advanced out of the perforator die block the pivoted transmitter yoke moves to the left away from the die block and the transmitter yoke extension permits the contact to close. A circuit is then completed through the sensing-shaft magnet which attracts its armature and pulls the sensing shaft clutch throwout lever (attached to it) out of engagement with its clutch member. This frees the sensing-shaft cam sleeve to rotate with the sensing shaft and operate the tape feeding and tape sensing mechanisms.

(2) After perforation is stopped, the pivoted sensing mechanism is pulled to the right along the tape, by means of the tape feeding mechanism, until the extension at the rear of the transmitter yoke opens the contact and breaks the circuit to the sensing-shaft magnet. When the sensing-shaft clutch throwout lever is released from the power of the magnet, it is pulled by its spring into engagement with the camming surface of the clutch driven member where it disengages the clutch teeth and stops the tape-feeding and tape-sensing mechanisms. The contact is adjusted in such a manner that it opens just as the sensing fingers sense the last perforation in the tape and the pivoted mechanism comes to rest against the die block.

#### d. TAPE DEPRESSOR (TAPE OPERATING BAIL)

A tape depressor is provided to start the tape moving downward into the storage compartment when transmission is stopped or does not keep up with the tape as it is being perforated. As soon as a loop of tape forms, an arm of the tape depressor engages the pivoted yoke to prevent its movement when the tape is being pulled from the storage compartment after transmission is again resumed. When the stored tape feeds through the sensing mechanism until the loop shortens, it lifts the tape depressor out of the way and frees the sensing mechanism for movement along the tape until it reaches the perforator die block.

#### e. TAPE FEEDING MECHANISM

(1) The tape is fed through the tape sensing mechanism or the tape sensing mechanism is advanced along the tape in order to sense the code combinations in the tape. This is accomplished by means of the tape feed-pin oscillating arm and the tape feed arm (Figure 19). These arms are actuated by the tape feed-arm oscillating-lever bail and the tape feed lever respectively. Each arm is pivotally attached to its associated part on the same center as the pivoted yoke and is operated in the pivoted yoke by cams on the sensing shaft. The tape feed-arm oscillating-lever bail is clamped to the tape feed-pin oscillating-lever extension, which rides on its cam; and the tape feed lever is clamped to the tape feed-lever extension. A roller on the lower end of the tape feed-lever extension rides on its cam. The tape feeding operations in the various steps of one complete cycle are as follows:

(a) In the initial position the pins in the upper end of the tape feed-pin oscillating arm engage with the tape (Figure 19). From this position the tape feed-pin oscil-

lating arm is advanced to its second position as the tape feed-arm roller rides down the cam surface of the tape feed-pin oscillating arm in response to action by its operating spring and cam. The tape feed-arm roller then wedges between the cam surface of the tape feed-pin oscillating arm and a surface on the transmitter yoke to hold the tape feed-pin oscillating arm firmly against its adjusting screw (Figure 20). At this time the tape feed-lever extension roller is held suspended from its cam due to the wedging position of the tape feed-arm roller.

(b) The tape is then clamped in position by the tape holding-finger pin (located just in front of the sensing pins) and the tape-out finger pin (located behind the sensing pins) pressing the tape upward against the transmitter lid. These fingers are operated by cams on the sensing shaft through the medium of their respective operating levers.

(c) Immediately thereafter, the oscillating-lever extension rides to the high part of its respective cam and pulls the tape feed pins downward from the tape. At the same time the tape feed-lever extension roller engages the low part of its cam (Figure 21).

(d) The tape feed-lever extension roller then rides to the high part of its cam and pushes the tape feed-arm roller up the cam surface on the tape feed-pin oscillating arm. This arm is then pulled horizontally to the right against its stop by means of two springs and takes a position directly under the next set of feed holes (Figure 22).

(e) The last step in this cycle is the upward movement of the tape feed-pin oscillating arm to re-engage the tape and the downward movement of the tape-out pin and holding pin to release their hold on the tape. These movements are brought about as the tape feed-pin oscillating-lever extension moves to the low part of its cam and the holding-pin lever and tape-out-pin lever cam followers move to the high part of their cams (the initial position).

(2) These movements take place with each complete revolution of the sensing-shaft cam sleeve to feed the tape through the sensing mechanism.

#### f. SIGNAL TRANSFER AND STORAGE MECHANISM

(1) At the time that step two in the tape-feeding cycle is taking place, the sensing fingers feel the tape and take a setting according to the code combination punched in the tape.

The selector levers may assume either of two positions according to whether their associated sensing-finger pins are blocked by the tape or pass through a hole in the tape (Figure 23). If tape, perforated with code combinations, is in the sensing mechanism at this time, the sensing fingers under these perforations project their pins through the holes in the tape and permit their selector-lever cam followers to be pulled toward the low part of their respective cams; while the other selector levers are held in their upward position as their sensing-finger pins strike the unperforated portions of the tape. The transfer-bail roller then rides to the high part of its cam and moves the T-transfer levers to the right against their selector levers.

(2) Under the above condition the mechanism is positioned so that the operated selector levers (those which have their sensing-finger pins through perforations in the tape) have their lower extensions in line with the lower arms of their respective T-transfer levers. The unoperated selector levers (those which have their sensing-finger pins against the tape) have their upper extensions in line with the upper arm of their respective T-transfer levers. When the transfer bail is operated by its cam (Figure 23), those T-transfer levers engaging the operated selector levers rotate clockwise and move their transfer slides upward; whereas, those T-transfer levers engaging the unoperated selector levers rotate counterclockwise and move their transfer slides to the downward position. Upward movement of a transfer slide places its respective switching-control contact pile-up in what is called the operated position; whereas, downward movement of a transfer slide places the contact pile-up in the unoperated position.

(3) It should be noted that if one or more switching-control contacts do not require a change in setting from the previous selections, there will be no engagement between the corresponding selector levers and their associated T-transfer levers. Therefore, the positions of the T-transfer lever, the transfer slide, and the contact bail will remain unchanged.

(4) Assuming that the code combination for the letter E is received, the operation of the mechanism from the perforated tape to the setting of the switching-control contacts is as follows: In the stop position (Figure 23) the sensing fingers are held flush with or below the top surface of the tape-guide plate on which the tape slides. This is due to the fact that the selector-lever cam followers are on the high part of their cams. As the cam sleeve of the sensing shaft rotates

in a counterclockwise direction to a point on the cam where the selector-lever cam followers are freed from the cam, the selector levers (being acted upon by their selector-lever springs) push the sensing fingers upward to sense the tape. Since the letter E code combination is perforated in the tape, the No. 1 sensing finger pin passes through the hole in the tape. The No. 1 selector lever continues to turn in a counterclockwise direction until its lower arm takes a position in line with the lower extension of the No. 1 T-transfer lever (Figure 24). The remaining sensing fingers (being blocked by the tape) hold the upper arms of their selector levers in line with the upper extensions of their T-transfer levers. The transfer-bail roller, which is also operated from a cam on the sensing-shaft assembly, then rides to the high part of its cam and moves the axis, on which the T-transfer levers are pivoted, to the right. As this motion is brought about, the lower extension of the No. 1 T-transfer lever engages the lower arm of the No. 1 selector lever and the T-transfer lever rotates slightly in a clockwise direction. The end of the T-transfer lever which is engaged in the No. 1 transfer slide moves the No. 1 transfer slide upward as the T-transfer lever rotates. A projection on this transfer slide rides on a cam-like surface of the No. 1 contact bail arm and presses the top of the arm to the left. At the top of this contact bail arm is an eccentric which is adjusted against an insulator that operates the No. 1 switching-control contact-spring pile-up.

(5) From the description of the foregoing action it may be seen that if the code being sensed in the tape permits a sensing finger to pass through the tape, the associated switching-control contact pile-up will be operated; or if the code being sensed in the tape blocks a sensing-finger pin the associated switching control contact pile-up will remain unoperated. These switching-control contacts originate electrical circuits which may be connected to external apparatus.

#### g. SIGNAL RETRANSMITTER

(1) Associated with the sensing mechanism is a distributing mechanism which consists of a magnet-controlled cam-shaft assembly and a set of distributor contacts. This mechanism is located directly under the sensing mechanism. Its function is to transmit pulse elements of a code combination which is set up on the five distributor contacts by means of electrical circuits from the switching-control contacts, and send them in the proper sequence to external apparatus. The contacts on the right side of the distributor contact assembly are wired

individually and terminate in the 33-point multiple plug. The start-stop, 1, 2, 3, 4, and 5 contacts on the left side of the distributor contact assembly are wired together (Figure 25) and terminate in the 33-point multiple plug.

(2) The distributor contacts are mechanically operated from the cam shaft through the medium of contact levers and close invariably with each revolution of the cam assembly (Figure 26). The cams are arranged on their assembly in such a manner that the contacts are made to close and open in timed relation to each other during each revolution of the cam shaft assembly. MARKING and SPACING impulses are sent to the line in the order in which they are set up electrically on the distributor contacts. Assume that the letter "E" code combination is set up mechanically on the switching-control contacts, and these contacts are connected directly to the distributor contacts instead of passing through the external apparatus. Under this condition the No. 1 switching-control contact pile-up is operated and connects current to the No. 1 distributor contact, while the Nos. 2, 3, 4, and 5 transfer contacts are open and no current is connected to the Nos. 2, 3, 4, and 5 distributor contacts. When operating locally the distributing shaft cam-sleeve assembly is set in motion when a contact, operated from the sensing shaft through the medium of a contact lever, closes and completes a circuit to the distributor magnet which becomes energized. Energization of the magnet attracts the magnet armature and causes the throwout lever (which is attached to the armature) to free the distributor cam-sleeve assembly so that it may rotate. While the cam-sleeve assembly rotates, the distributor start-stop contact opens and sends a start (SPACING) impulse to the line. This contact remains open until the Nos. 1, 2, 3, 4, and 5 distributor contacts all close and open in sequence. Since No. 1 distributor contact has current, and Nos. 2, 3, 4, and 5 distributor contacts have no current, a MARKING impulse followed by four SPACING impulses enters the line. The start-stop contact then closes to send a stop (MARKING) impulse to the line. This completes the cycle. Thus a code combination for the letter E which was set up on the switching-control contacts of separate electrical circuits is sent into the line through the distributor contacts.

(3) The distributor auxiliary contact, closes after the No. 3 distributor contact opens in the foregoing cycle and opens after the start-stop contact closes.

(4) The pattern of the code combinations to be sent to the line may be received from the switching-control contacts associated with the sensing mechanism previously described through an external apparatus, or it may be received from remote relay controlled contacts. If the code combination to be sent into the line comes from a remote source through remotely controlled relays the sensing mechanism (if operating) may be stopped from the remote source to send a different message to the line. After the transmission from the remote source is completed the sensing mechanism may be released and local transmission resumed. While the foregoing operations are taking place, an incoming message may be received and stored in the tape for future transmission.

#### 4. CONTACT ASSEMBLIES AND OTHER FEATURES

##### a. SWITCHING CONTACTS (FRXD9 ONLY) (Figure 1)

The FRXD9 is equipped with a set of switching contacts located above the code bars. These contacts are actuated by specially designed pull bars which respond to code combinations received by the selector in the same manner as other pull bars.

##### b. UNIVERSAL CONTACTS (Figure 27)

The universal contacts located under the

base casting are actuated by an extension of the main-bail plunger through the medium of a contact lever. These contacts are actuated with each downward stroke of the main bail and function to apply battery to associated contacts.

##### c. TAPE-FEED-INDICATOR CONTACT (Figure 28)

The tape-feed-indicator contact assembly is attached to the base casting directly to the rear of the prepunch mechanism. A contact lever extends forward to a position directly above the tape as it passes from the prepunch mechanism to the code punch mechanism. If for some reason the tape becomes taut, the contact lever is raised by the tape. Rotation of the contact lever opens the tape-feed-indicator contact and breaks a circuit through it. When this circuit breaks, an audible or visible signal warns the attendant that the unit is not feeding tape properly.

##### d. MISCELLANEOUS FEATURES (See Figures 1 and 2)

The Reperforator Transmitter Distributors are equipped with a code-munch feed-pawl release lever to facilitate manual movement of the tape through the code punch block. They are also equipped with a prepunch feed-pawl release lever which, when depressed, permits rotation of the prepunch feed roll in either direction.

SWITCHING CONTACT CABLE

SWITCHING CONTACT ASSEMBLY

CODE BARS

SENSING SHAFT

DISTRIBUTING SHAFT

FEED-PAWL RELEASE LEVER

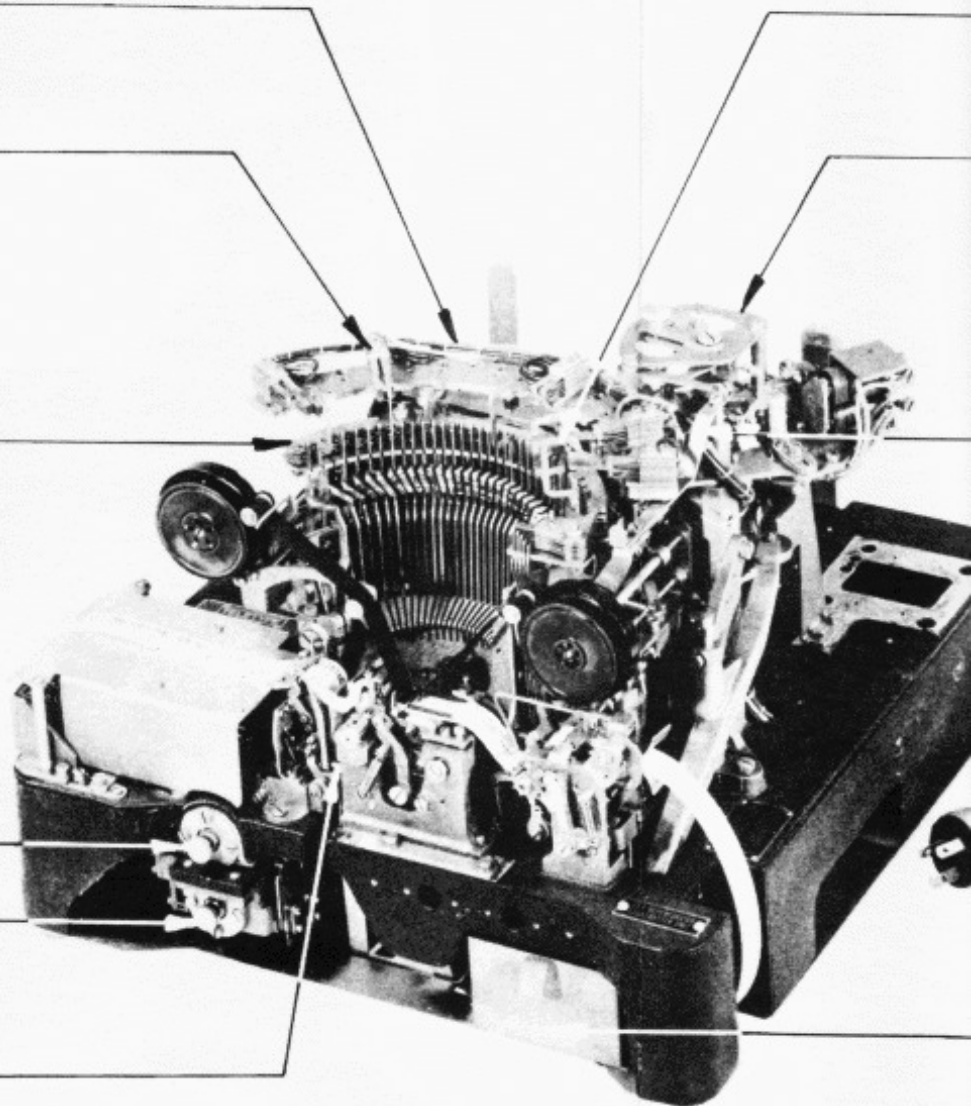

REPERFORATOR TRANSMITTER DISTRIBUTOR

(FRXD 9)

FIGURE 1



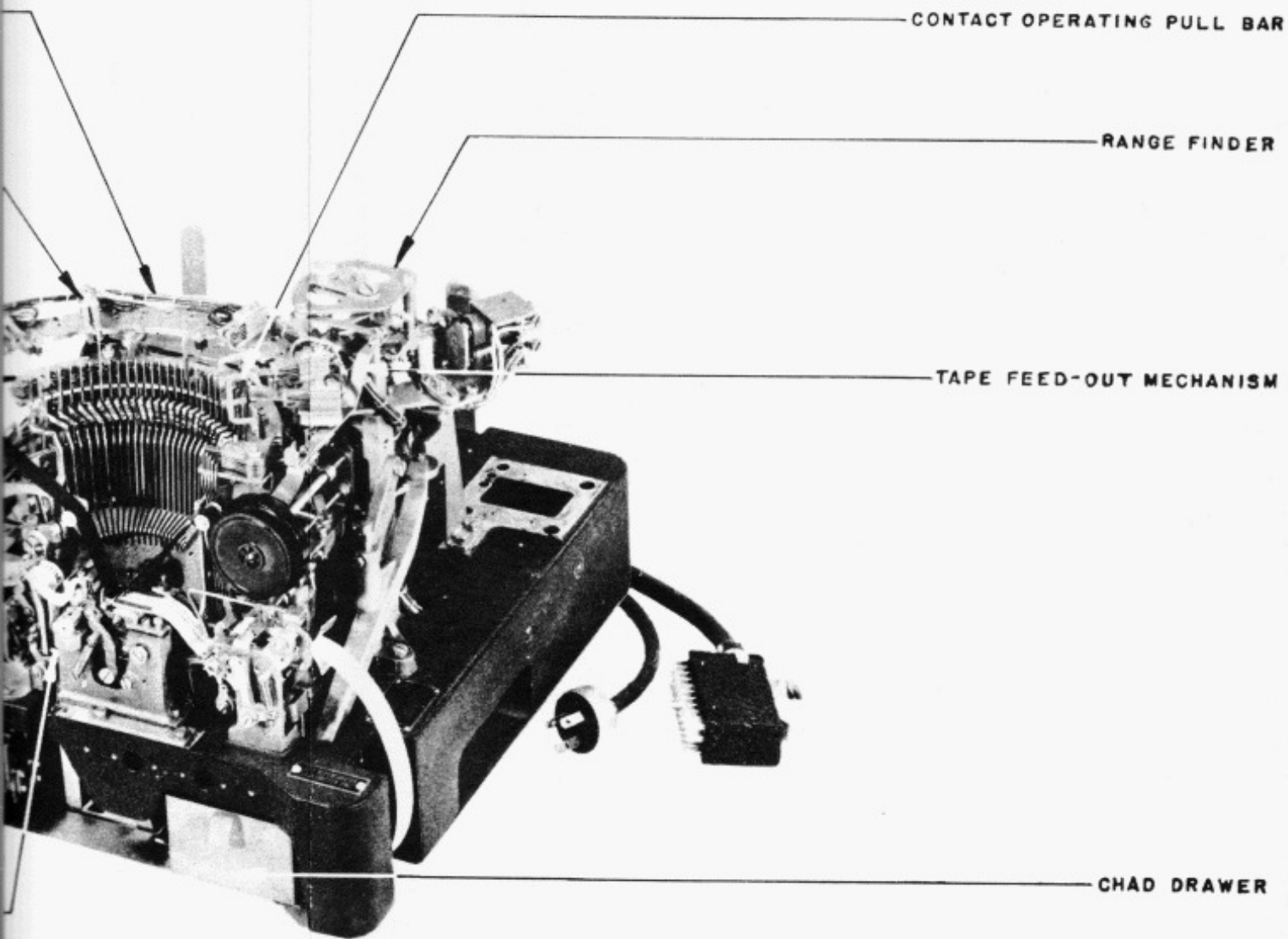

PERFORATOR TRANSMITTER DISTRIBUTOR

(FRXD 9)

FIGURE 1

PULL BARS

TYPE BARS

TYPE BAR SEGMENT

TAPE DEPRESSOR

PIVOTED TRANSMITTER

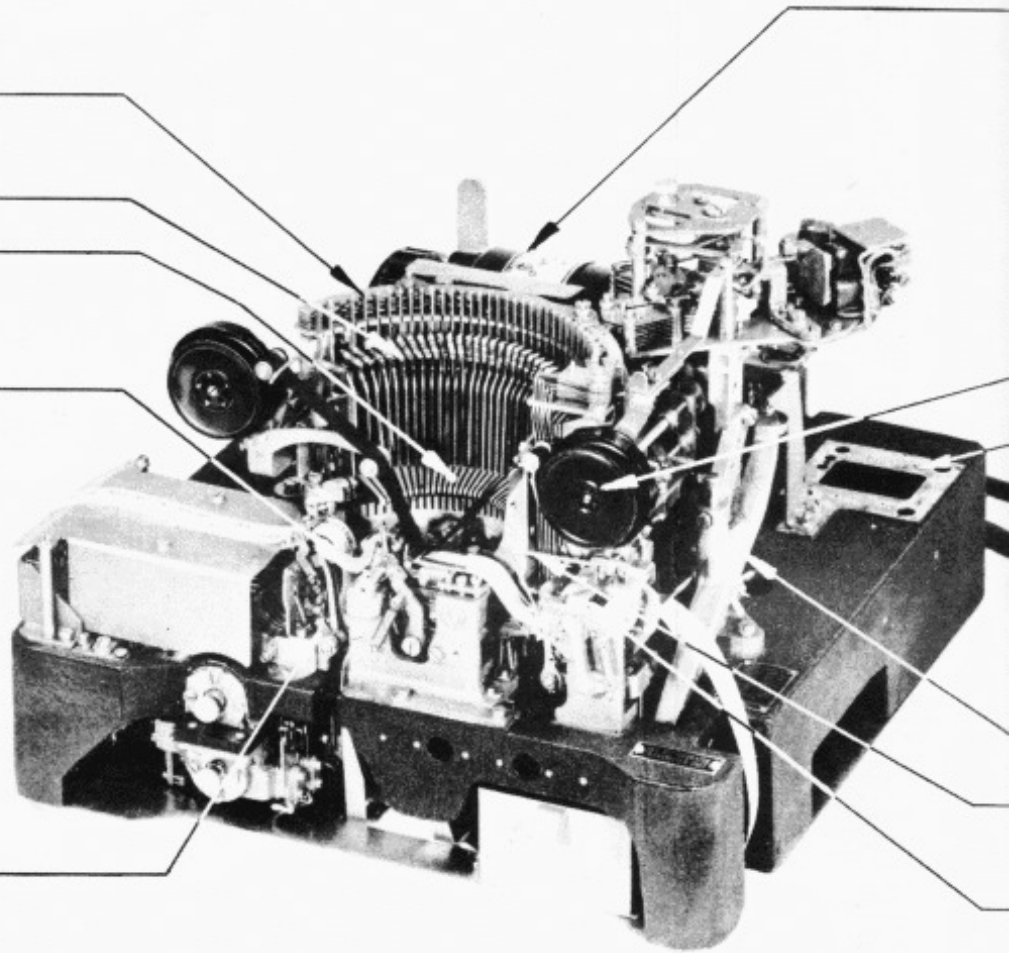

REPERFORATOR TRANSMITTER DISTRIBUTOR  
(FRXD 10)

FIGURE 2

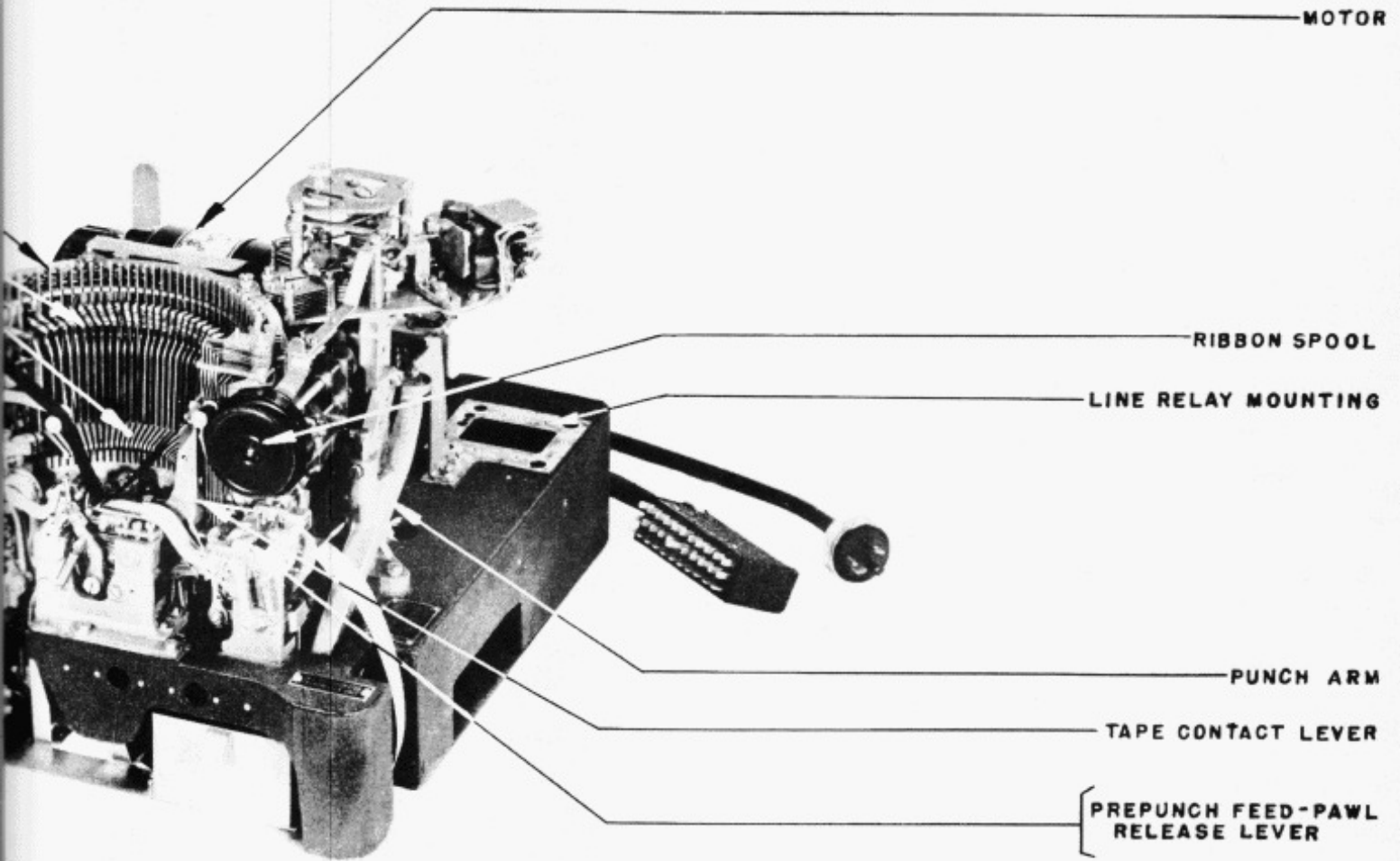

PERFORATOR TRANSMITTER DISTRIBUTOR  
(FRXD 10)  
FIGURE 2

UPPER CASE																											BLANK	C.R.	L.F.	SPACE	LTR	FIG
	-	5	8	3	4	B	#	8	1	2	3	4	7	9	0	1	4	5	7	3	2	/	6	"	∞	∞	∞	∞				
LOWER CASE	A	B	C	D	E	F	G	H	I	J	K	L	M	N	O	P	Q	R	S	T	U	V	W	X	Y	Z	∞	∞	∞	∞		
1	●	●	●	●	●				●	●						●	●			●	●	●	●	●	●					●	●	
2	●		●				●		●	●	●	●				●	●	●			●	●	●	●	●					●	●	
FEED HOLES	○	○	○	○	○	○	○	○	○	○	○	○	○	○	○	○	○	○	○	○	○	○	○	○	○	○	○	○	○	○	○	
3		●			●			●	●	●			●	●	●	●	●		●	●	●	●	●	●	●					●	●	
4		●	●	●		●	●			●	●		●	●	●	●		●				●	●					●		●	●	
5		●				●	●					●	●	●	●	●			●	●	●	●	●	●	●					●	●	

FIGURE 3

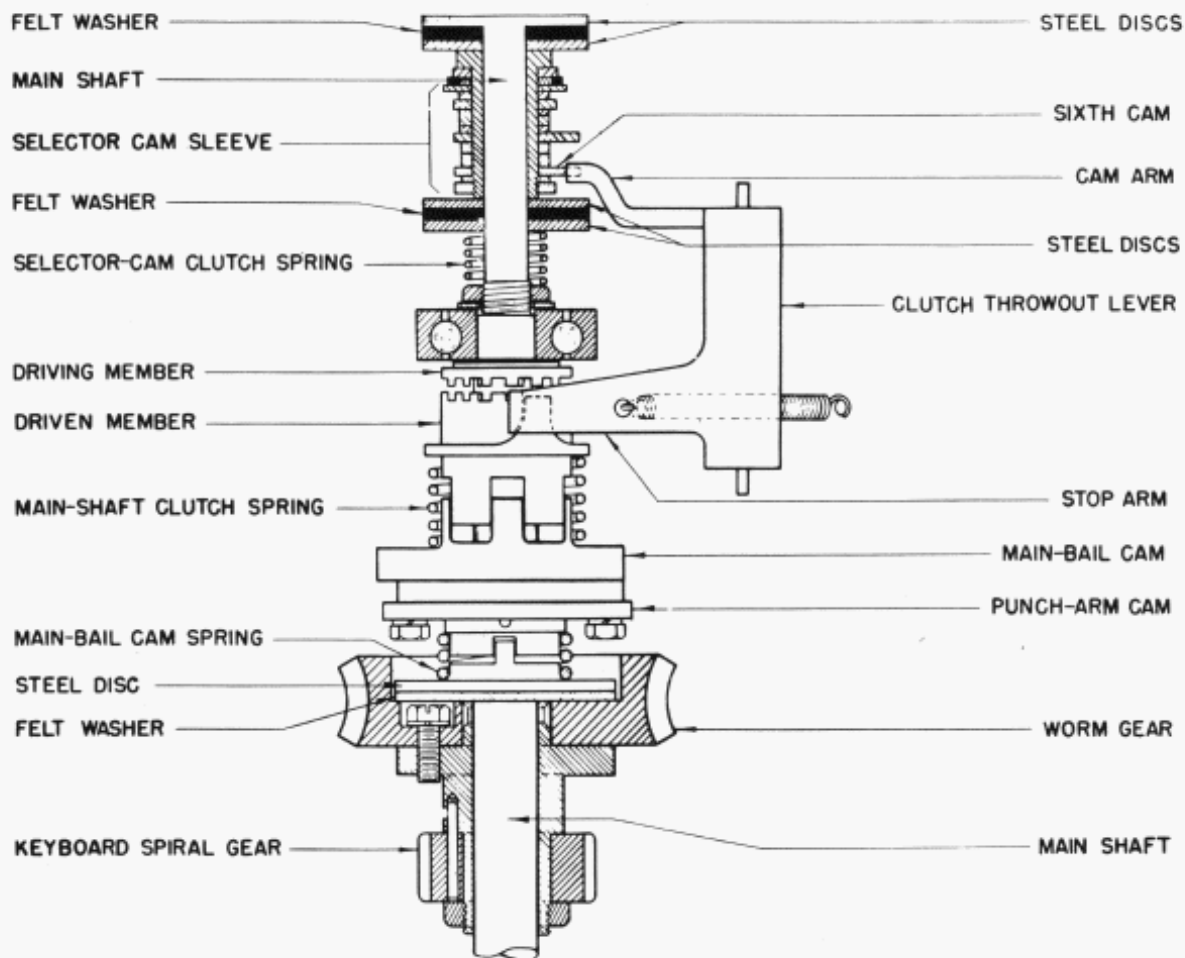

RIGHT SIDE VIEW  
FIGURE 4

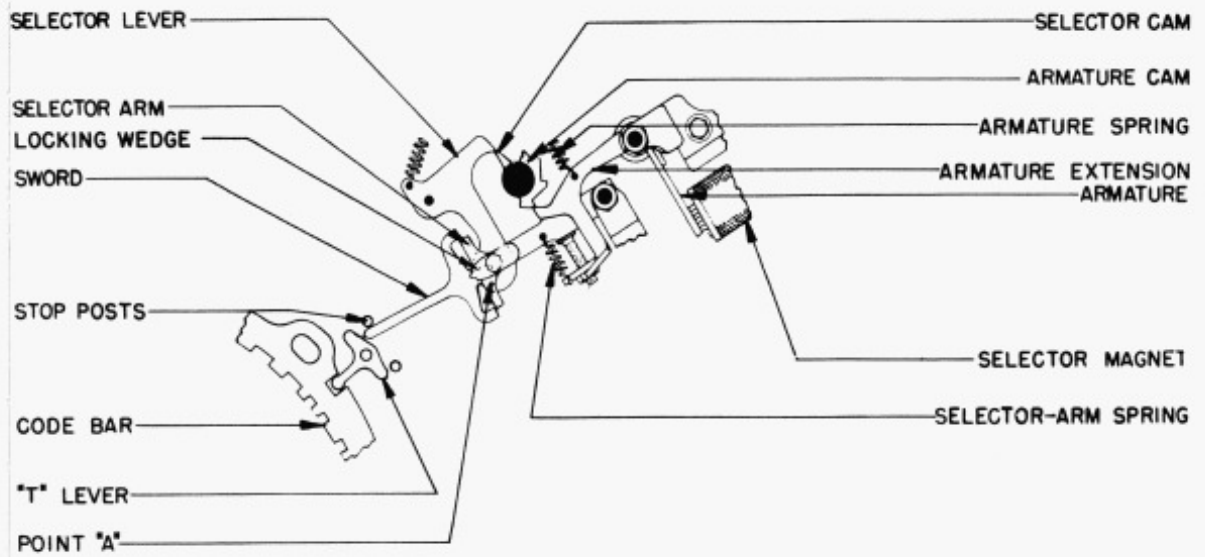

TOP VIEW  
FIGURE 5

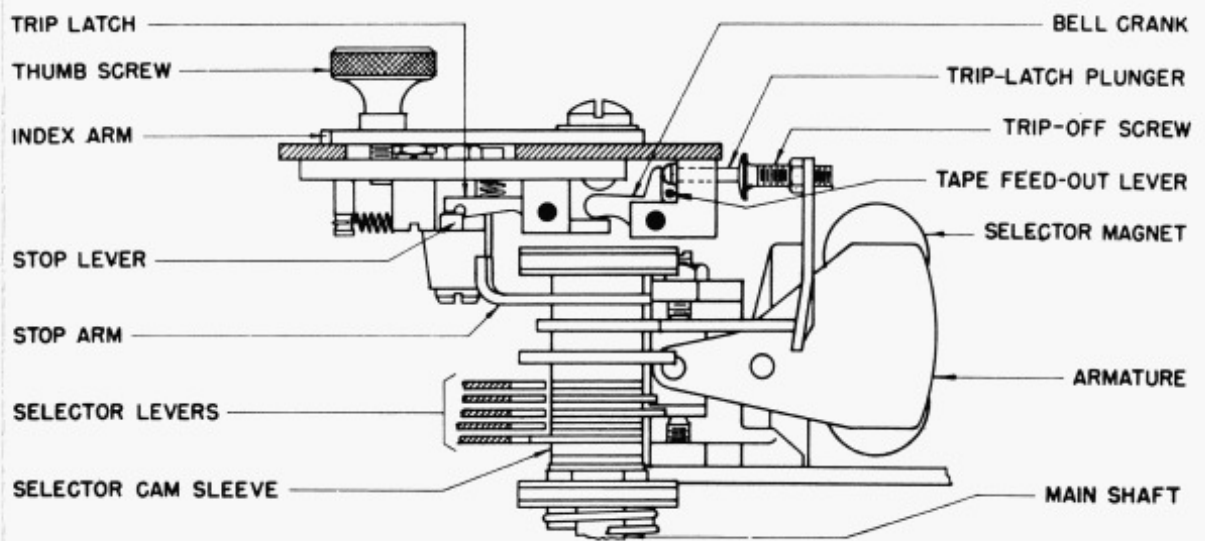

LEFT FRONT VIEW  
FIGURE 6

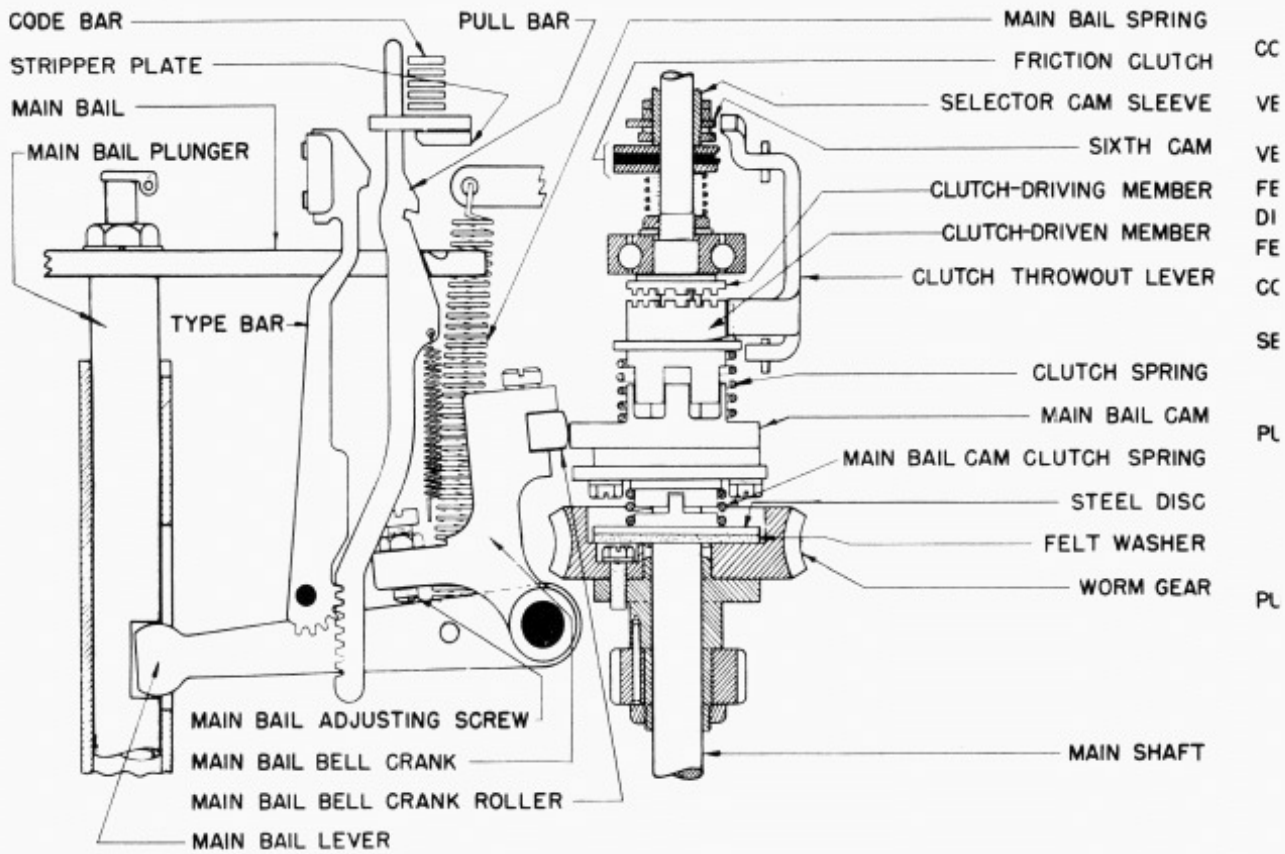

RIGHT SIDE VIEW  
FIGURE 7

CC  
VE  
VE  
FE  
DI  
FE  
CC  
SE  
PL  
PL

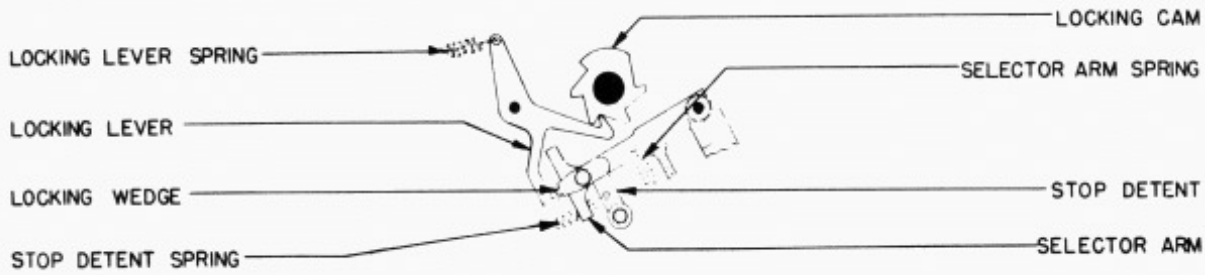

TOP VIEW  
FIGURE 8

FE  
DI  
TZ  
TZ  
FE  
FE  
S'

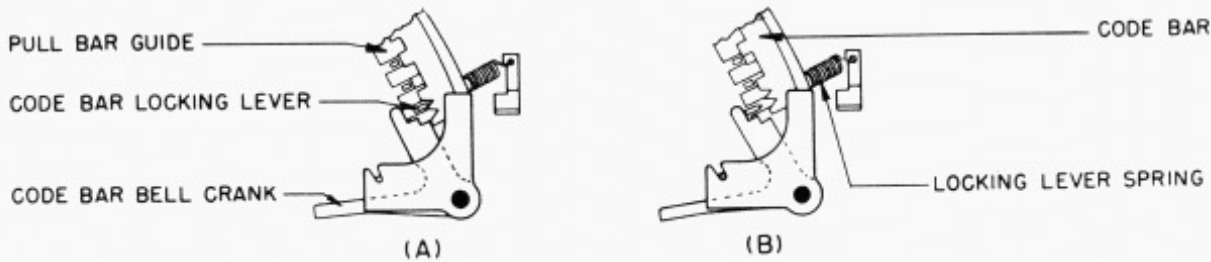

TOP VIEW  
FIGURE 9

FE

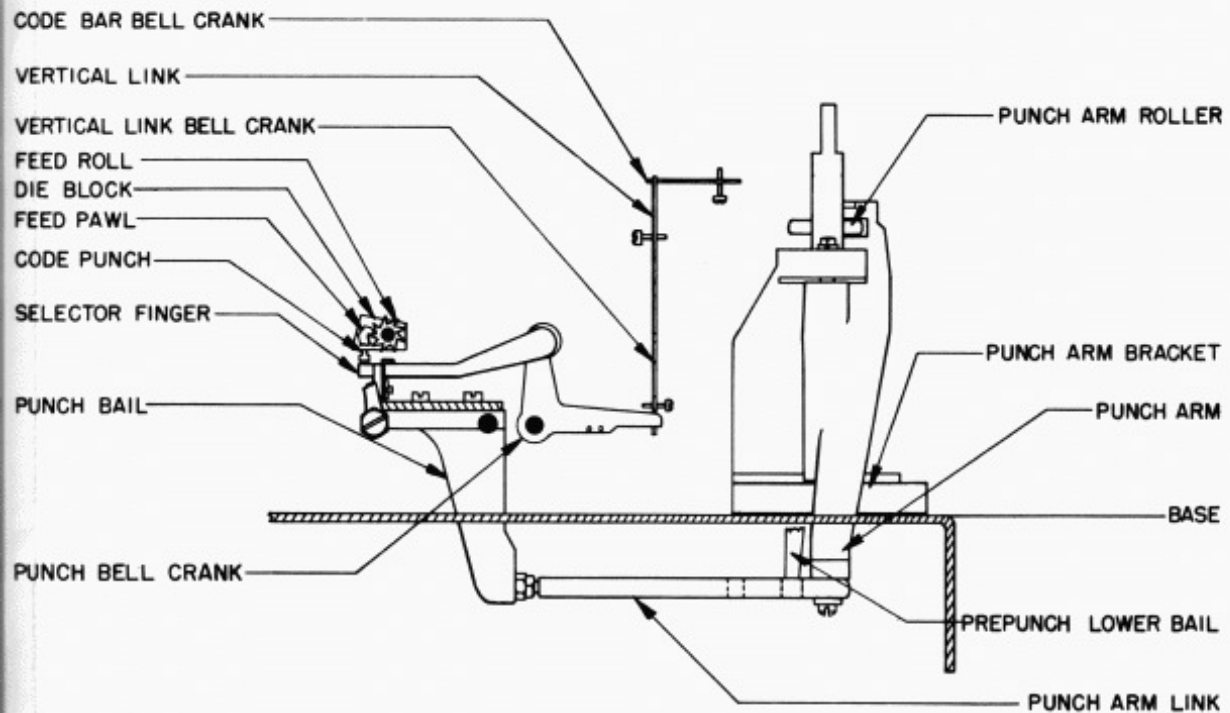

FRONT VIEW  
FIGURE 10

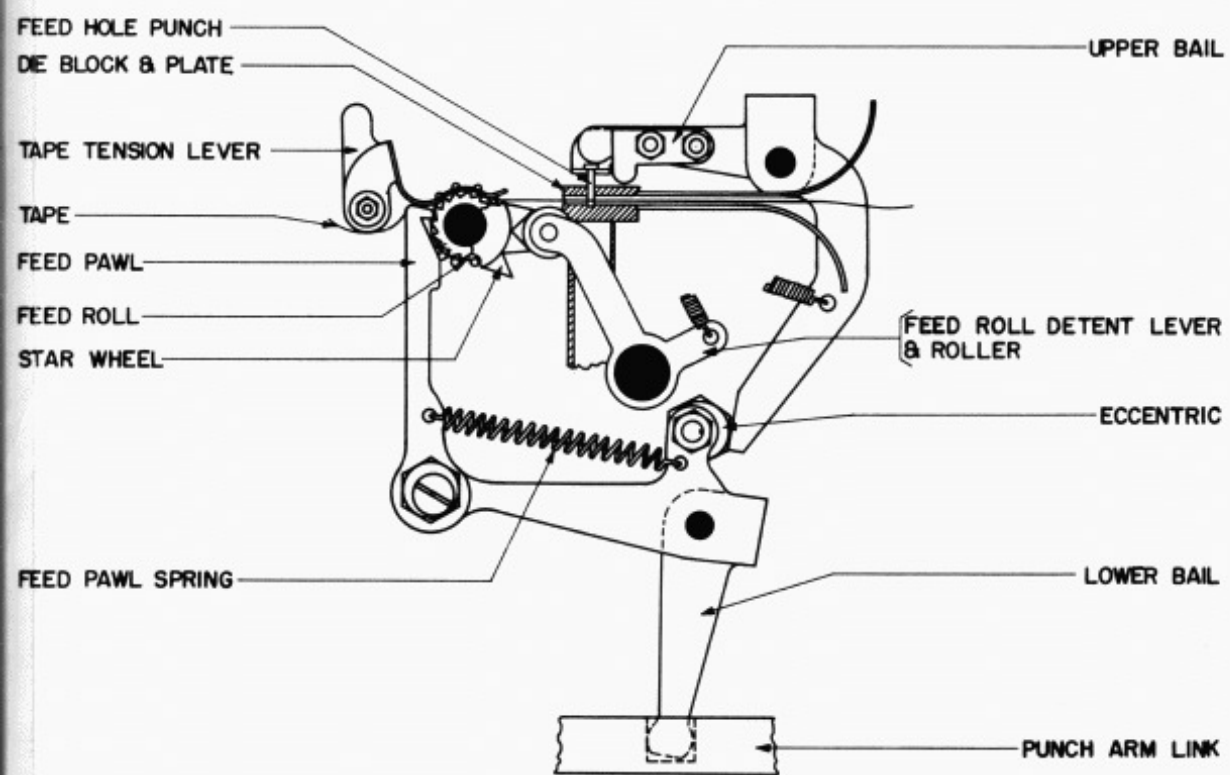

FRONT VIEW  
FIGURE 11

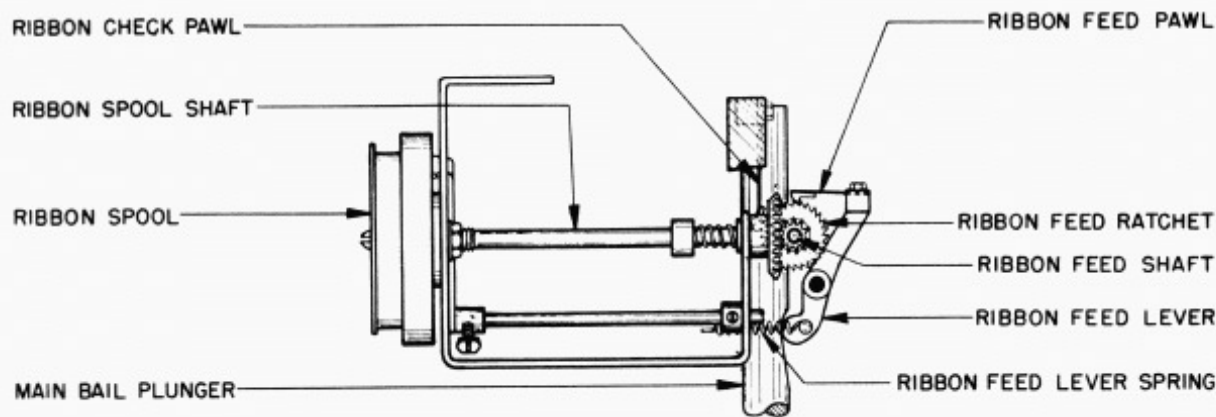

RIGHT SIDE VIEW  
FIGURE 12

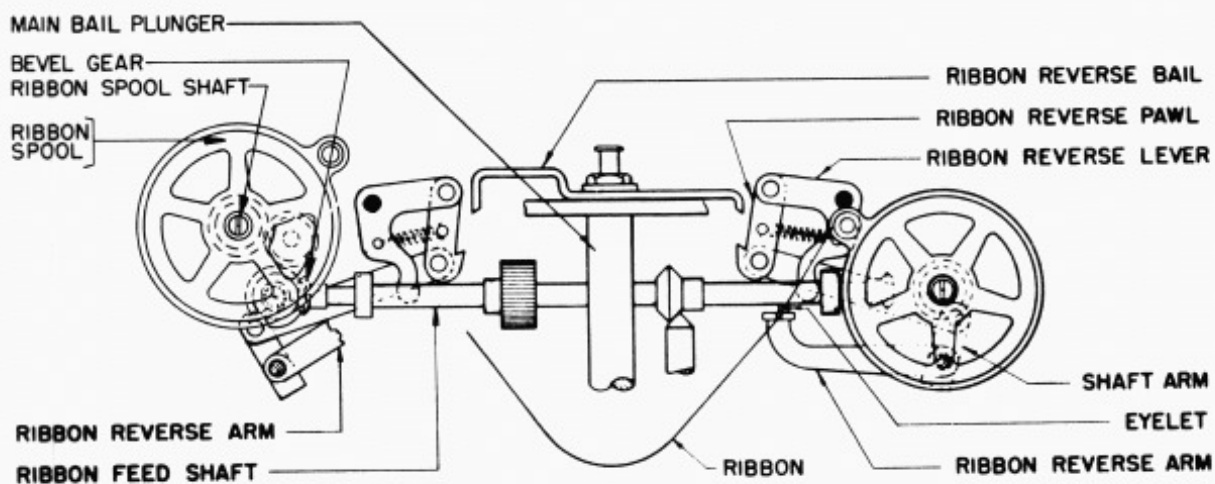

FRONT VIEW  
FIGURE 13

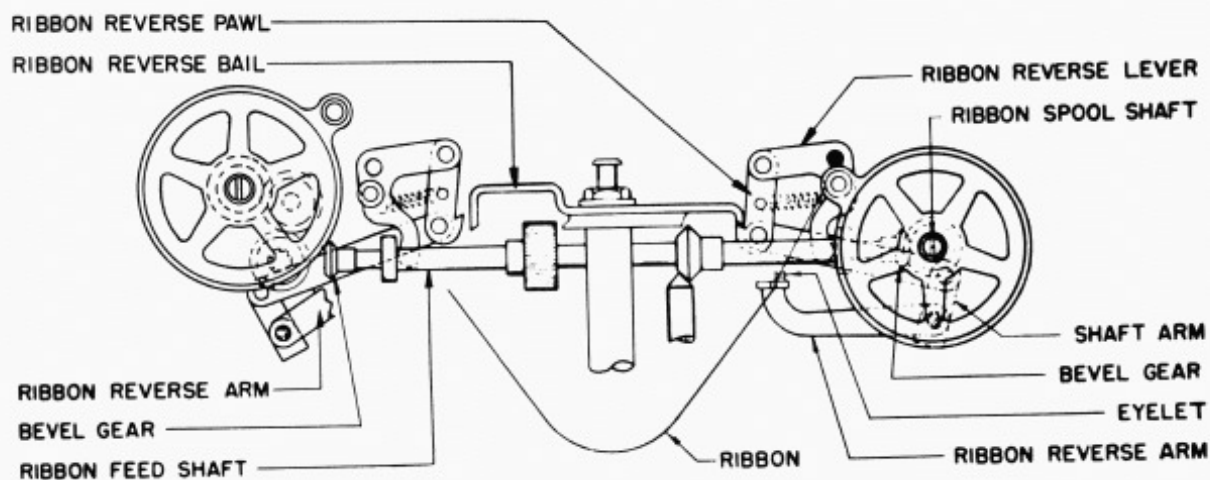

FRONT VIEW  
FIGURE 14



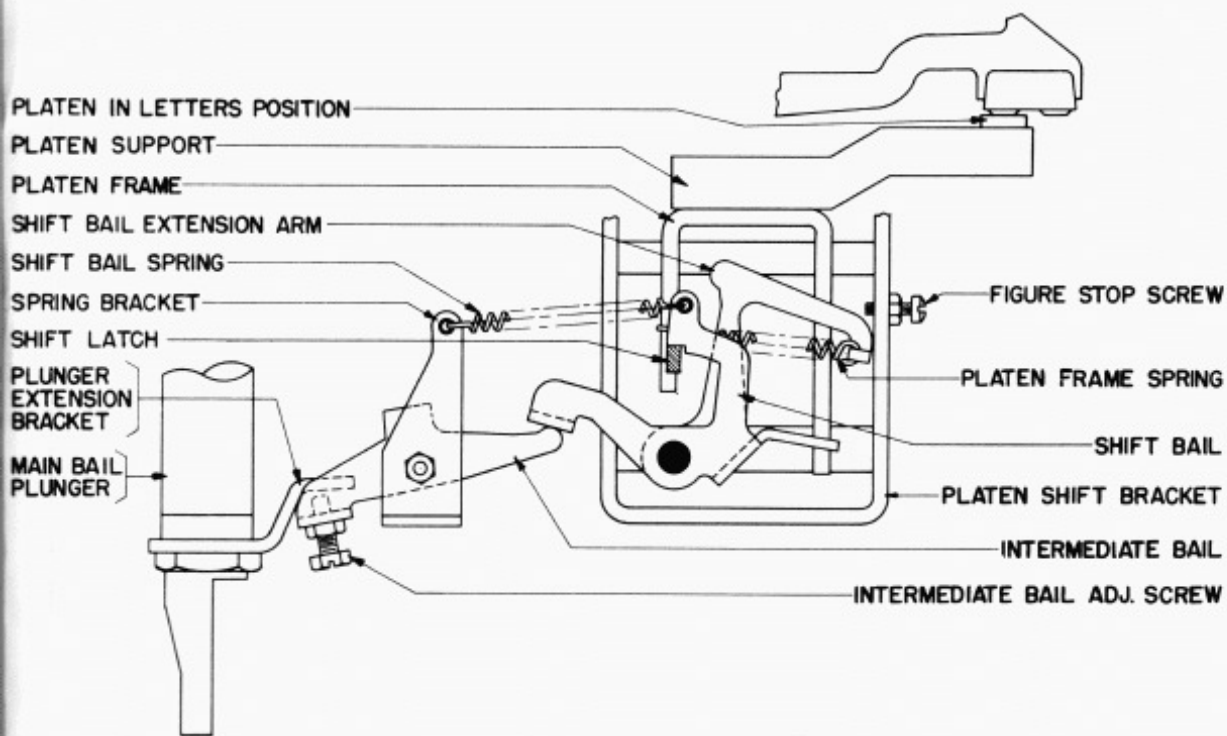

LEFT SIDE VIEW  
FIGURE 15

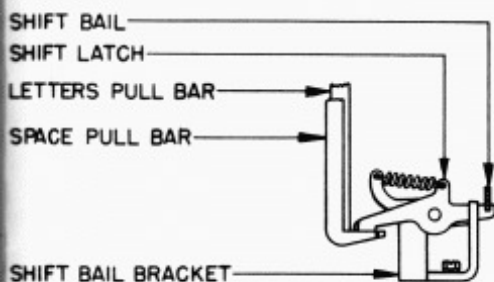

FRONT VIEW  
FIGURE 16

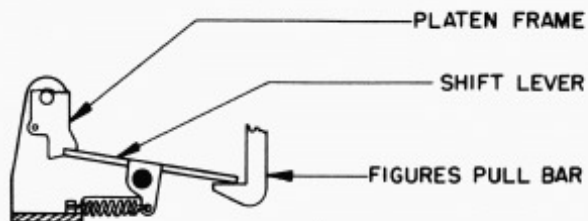

FRONT VIEW  
FIGURE 17

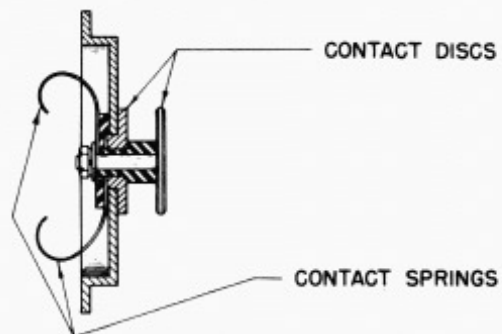
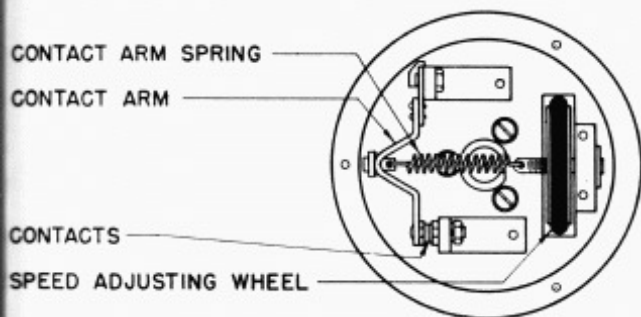
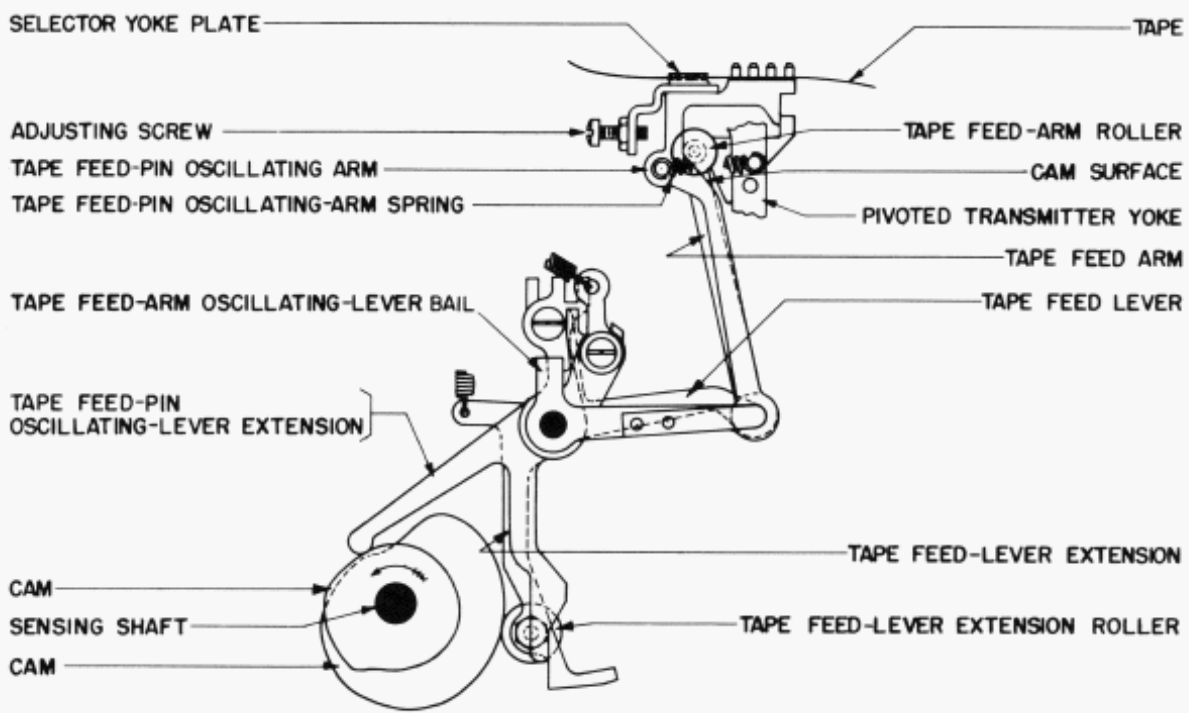
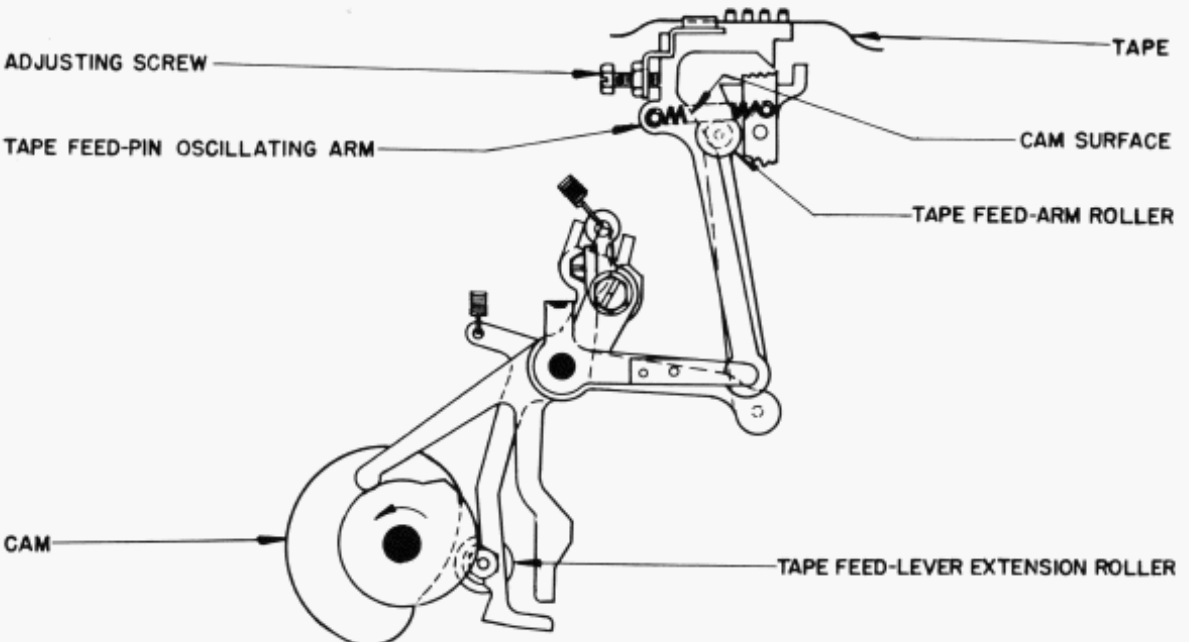

FIGURE 18



FRONT VIEW  
FIGURE 19



FRONT VIEW  
FIGURE 20

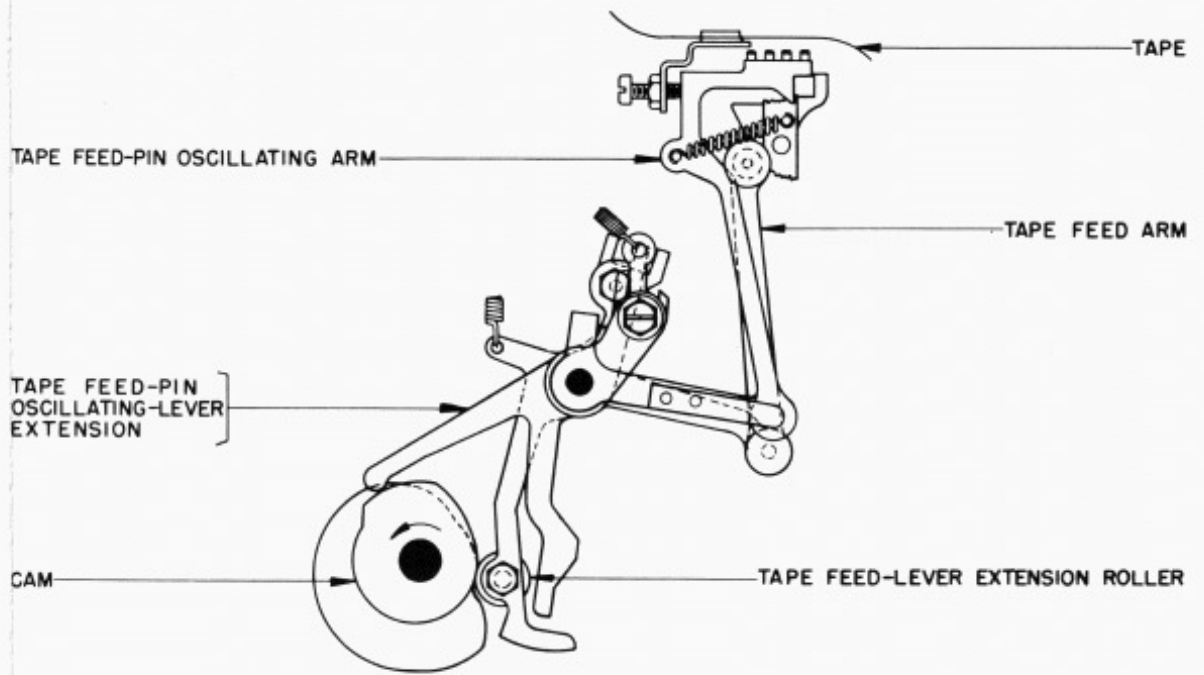

FRONT VIEW  
FIGURE 21

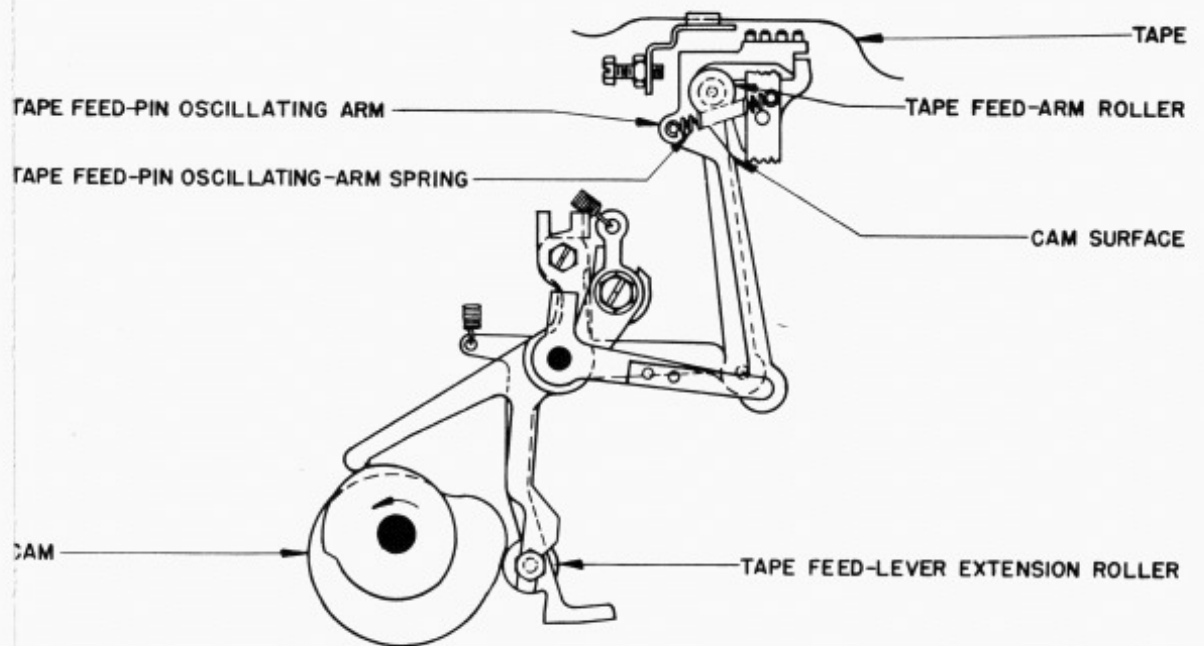

FRONT VIEW  
FIGURE 22

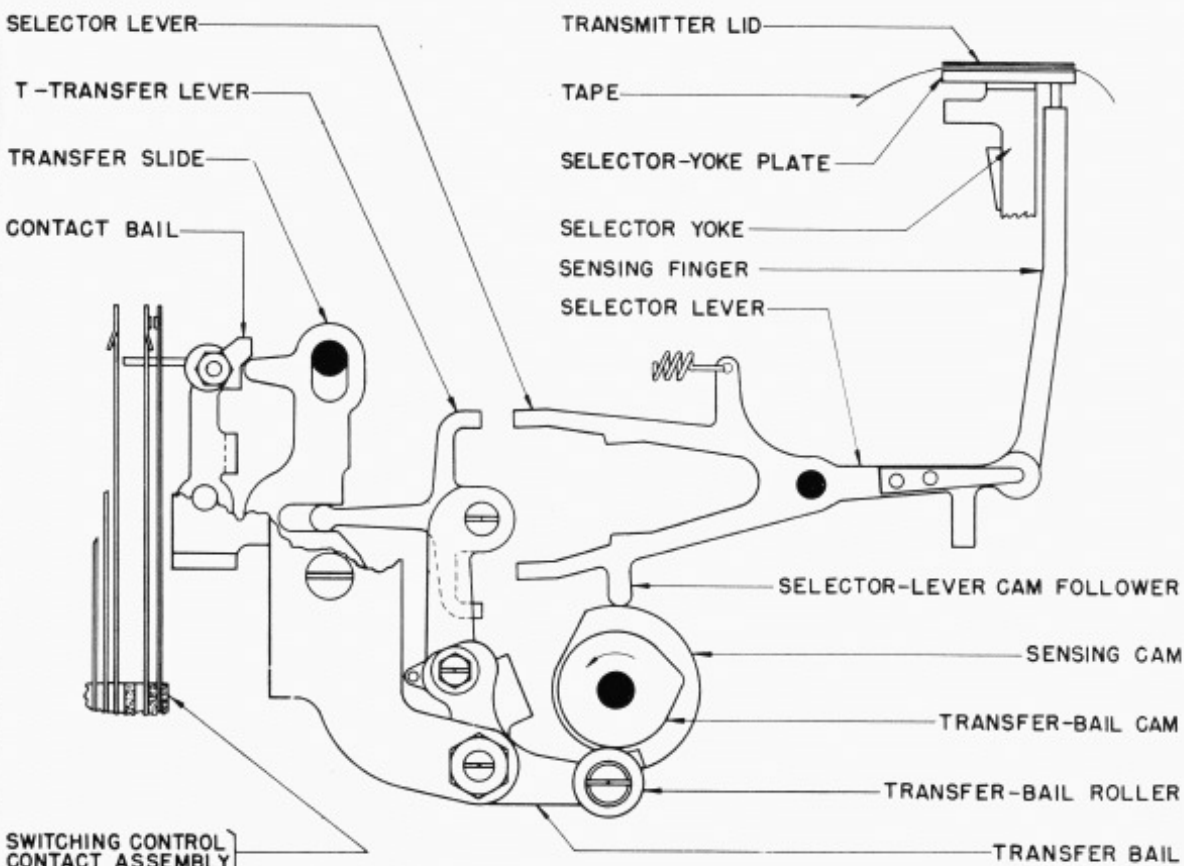

FRONT VIEW  
FIGURE 23

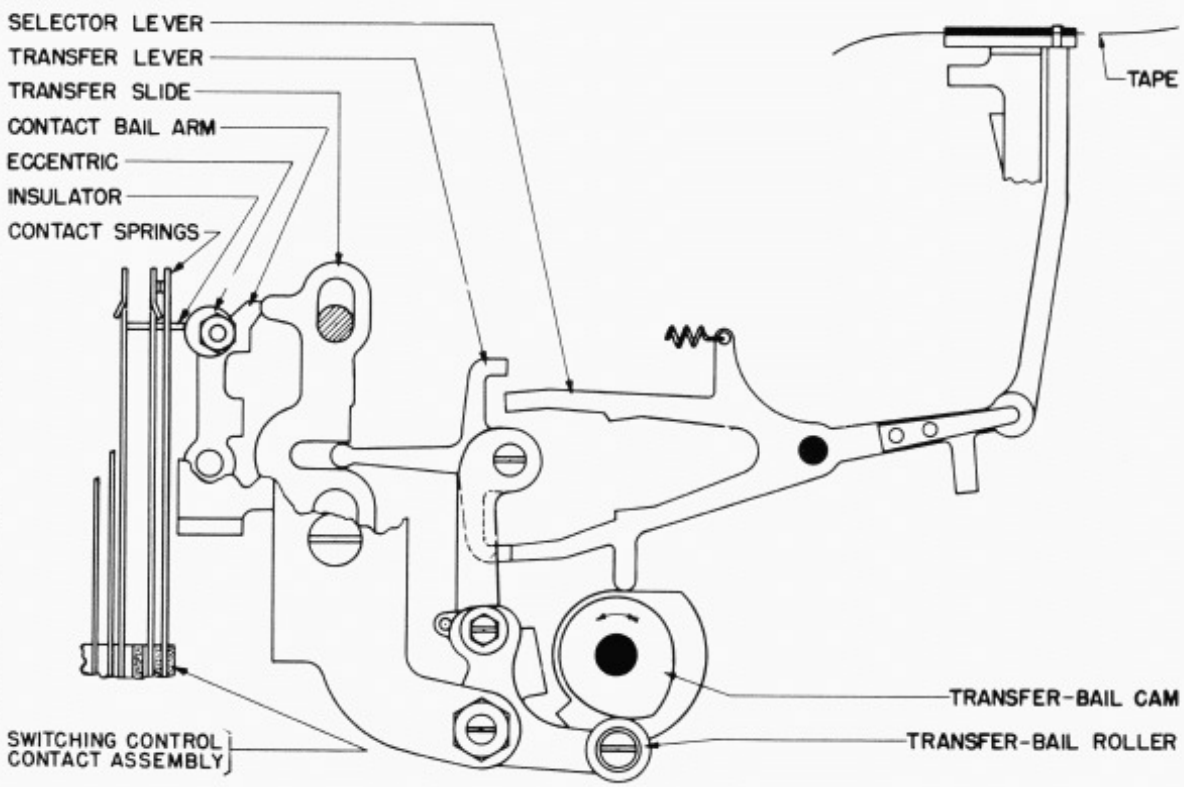

FRONT VIEW  
FIGURE 24

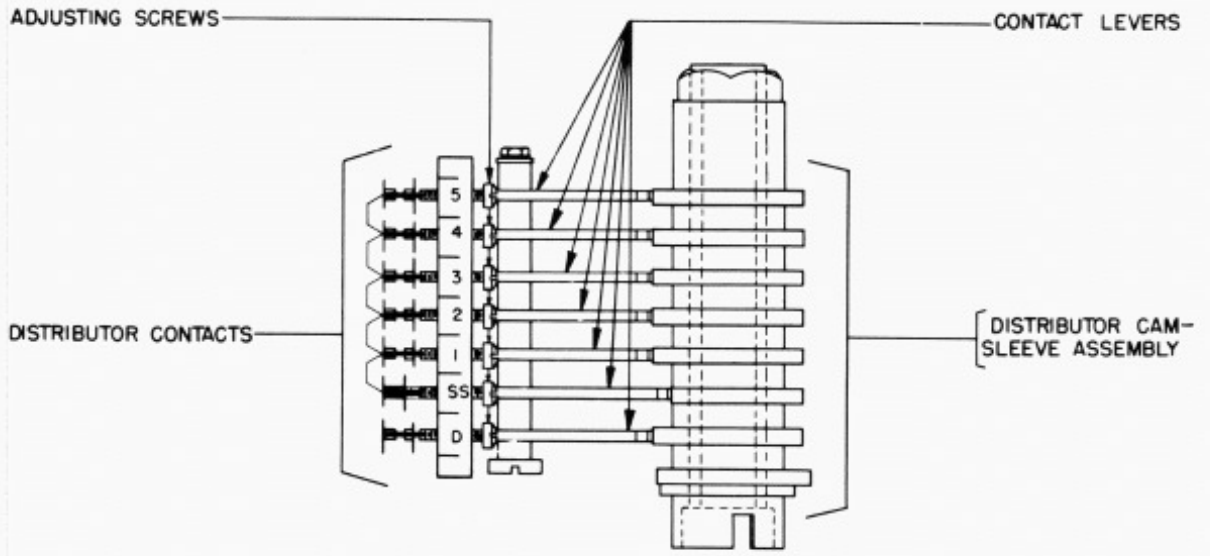

BOTTOM VIEW  
FIGURE 25

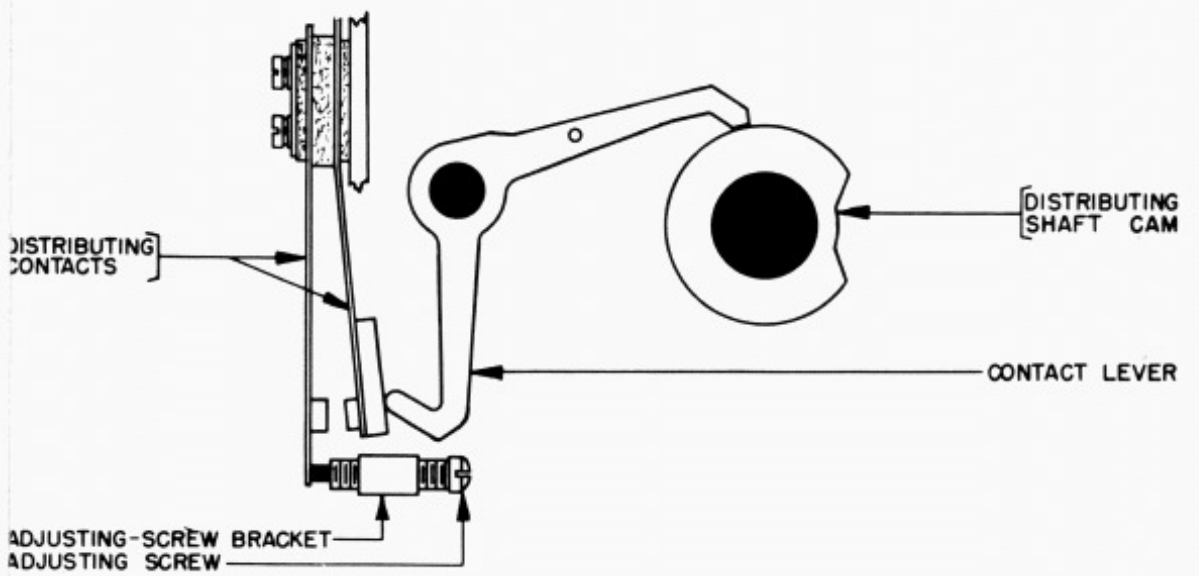

FRONT VIEW  
FIGURE 26

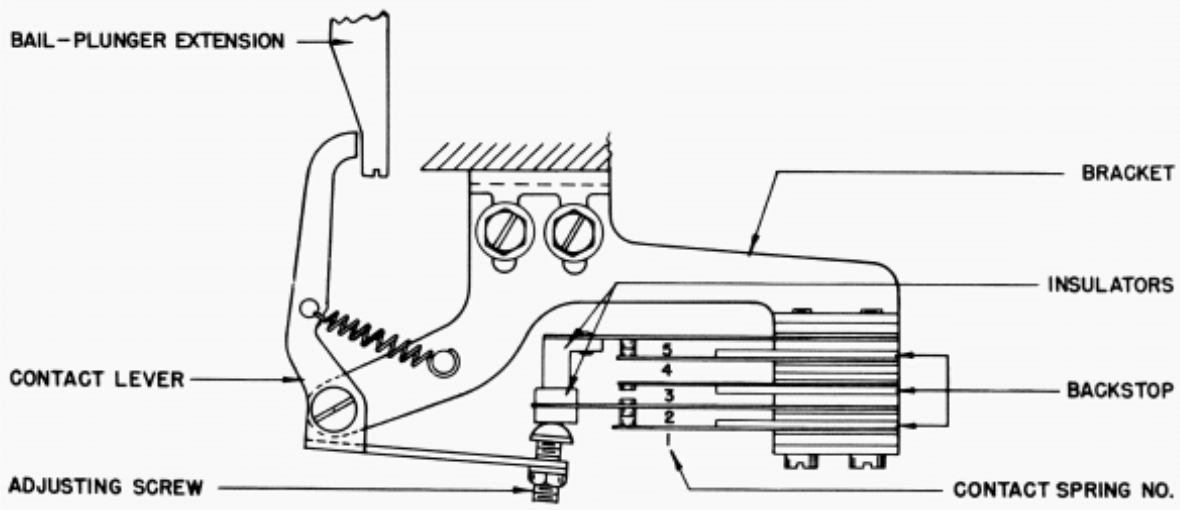

FIGURE 27

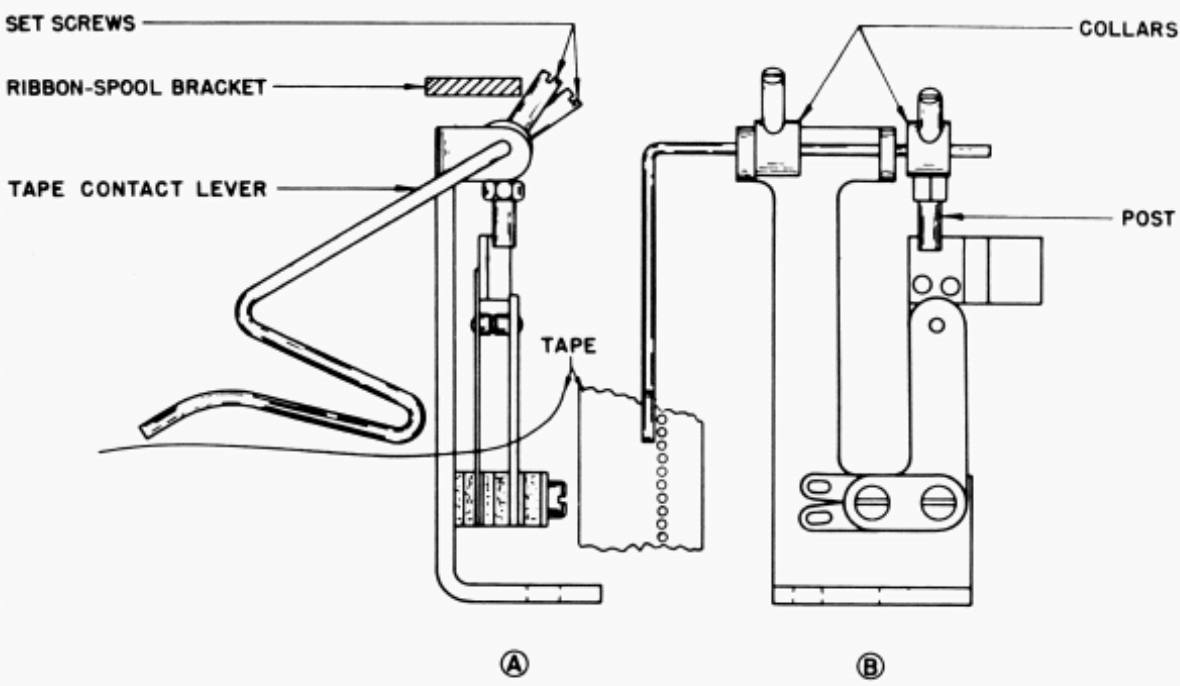

FIGURE 28