

BULLETIN 141B

DESCRIPTION AND ADJUSTMENTS
MODELS 14 AND 20 TRANSMITTER DISTRIBUTOR
MODEL 14 DISTRIBUTOR, TWO-CHANNEL
START-STOP TRANSMITTER DISTRIBUTOR,
SIGNAL DISTORTION TEST SET (TAPE
OPERATED)



TELETYPE[®]
CORPORATION

5555 TOUHY AVENUE, SKOKIE, ILLINOIS

BULLETIN 141B

DESCRIPTION AND ADJUSTMENTS
MODELS 14 AND 20 TRANSMITTER DISTRIBUTOR
MODEL 14 DISTRIBUTOR, TWO-CHANNEL
START-STOP TRANSMITTER DISTRIBUTOR,
SIGNAL DISTORTION TEST SET (TAPE
OPERATED)

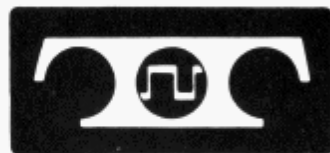

TELETYPE[®]
CORPORATION

5555 TOUHY AVENUE, SKOKIE, ILLINOIS

LIST OF EFFECTIVE PAGES

APRIL, 1964

(Supersedes Issue of July, 1962)

PAGE NUMBER	CHANGE IN EFFECT
Cover Page	CHANGE 2
Title Page	CHANGE 2
A	CHANGE 2
B to D	ORIGINAL
E to I	CHANGE 1
1-1	CHANGE 1
1-2	CHANGE 2
1-3 to 1-8	CHANGE 1
2-1 to 2-6	CHANGE 1
2-7	CHANGE 2
2-8	CHANGE 1
2-9 to 2-10	CHANGE 2
2-11 to 2-12	CHANGE 1
2-13	CHANGE 2
2-14 to 2-18	CHANGE 1
2-19	CHANGE 2
2-20 to 2-21	CHANGE 1
2-22	CHANGE 2
2-23 to 2-29	CHANGE 1
3-0 to 3-0b	CHANGE 1
3-1	ORIGINAL
3-1a	CHANGE 1
3-2 to 3-8	ORIGINAL
3-9	CHANGE 1
3-10	ORIGINAL
3-11	CHANGE 1
3-12 to 3-17	ORIGINAL
3-18 to 3-19	CHANGE 1
3-20 to 3-22	ORIGINAL
3-23	CHANGE 1

The above list indicates the effective pages as of the date of issue. Upon receipt of change pages, insert them numerically and discard any superseded pages.

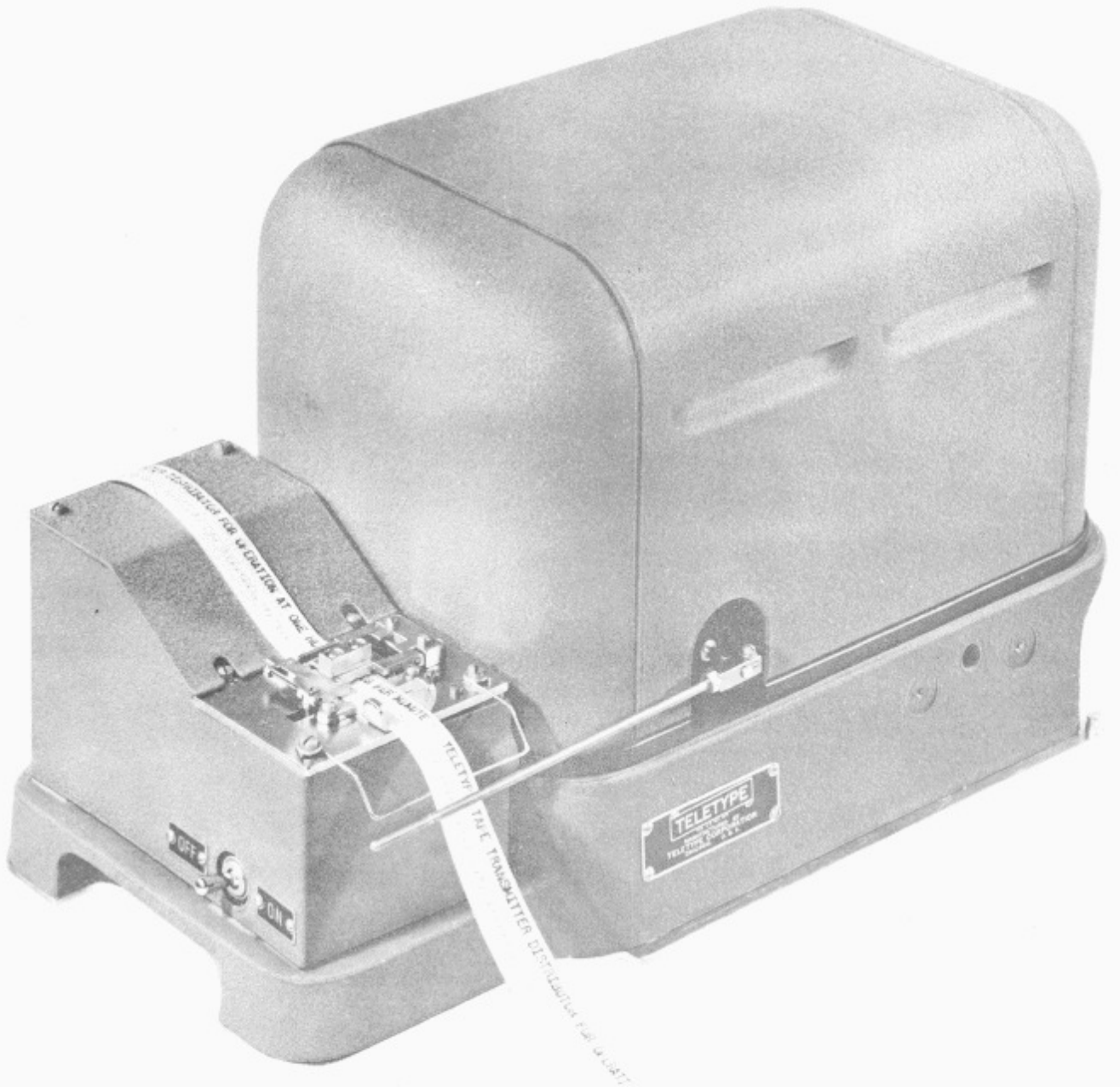

TRANSMITTER DISTRIBUTOR

141B



DISTRIBUTOR

ORIGINAL

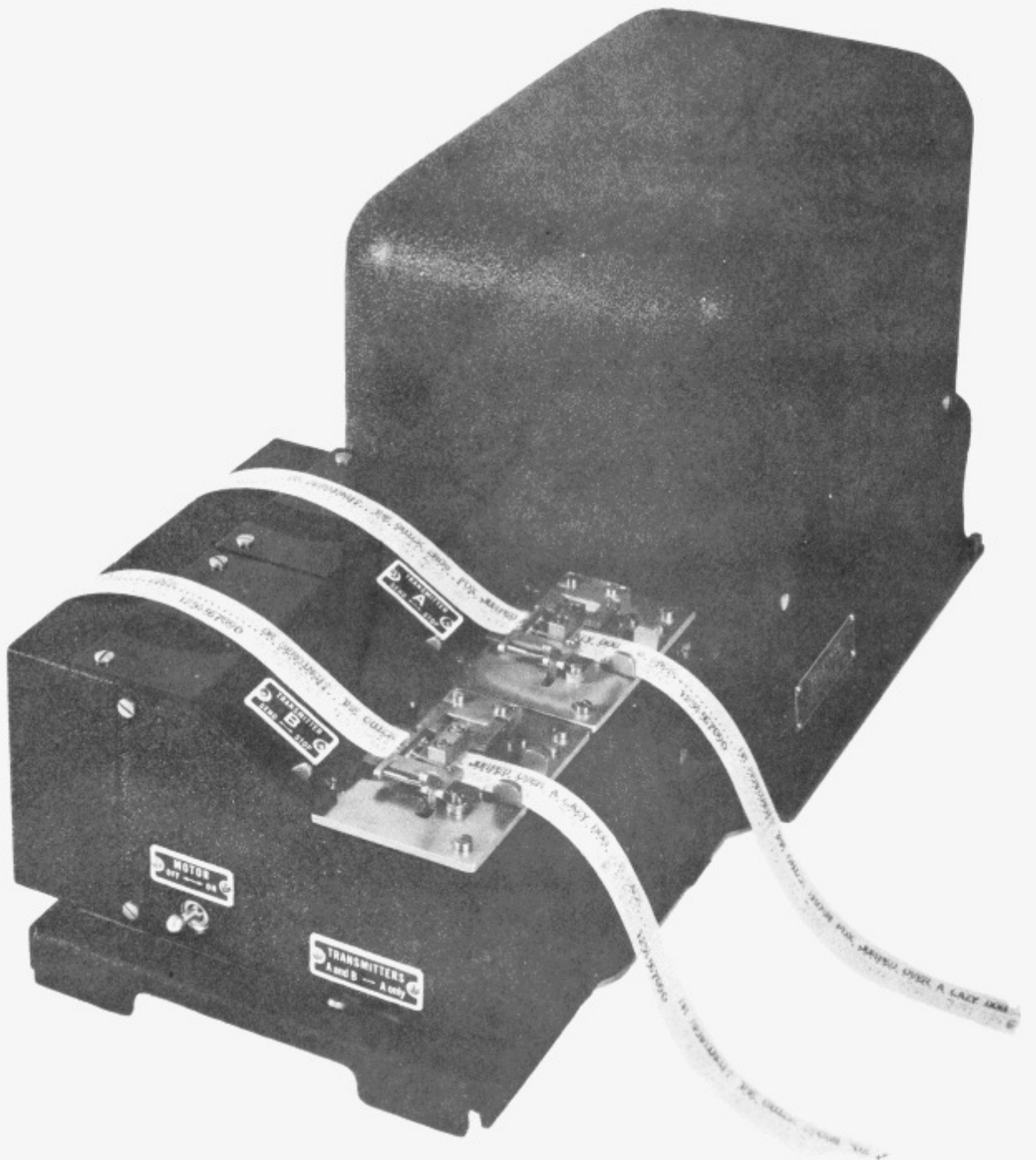

TWO-CHANNEL START-STOP TRANSMITTER DISTRIBUTOR

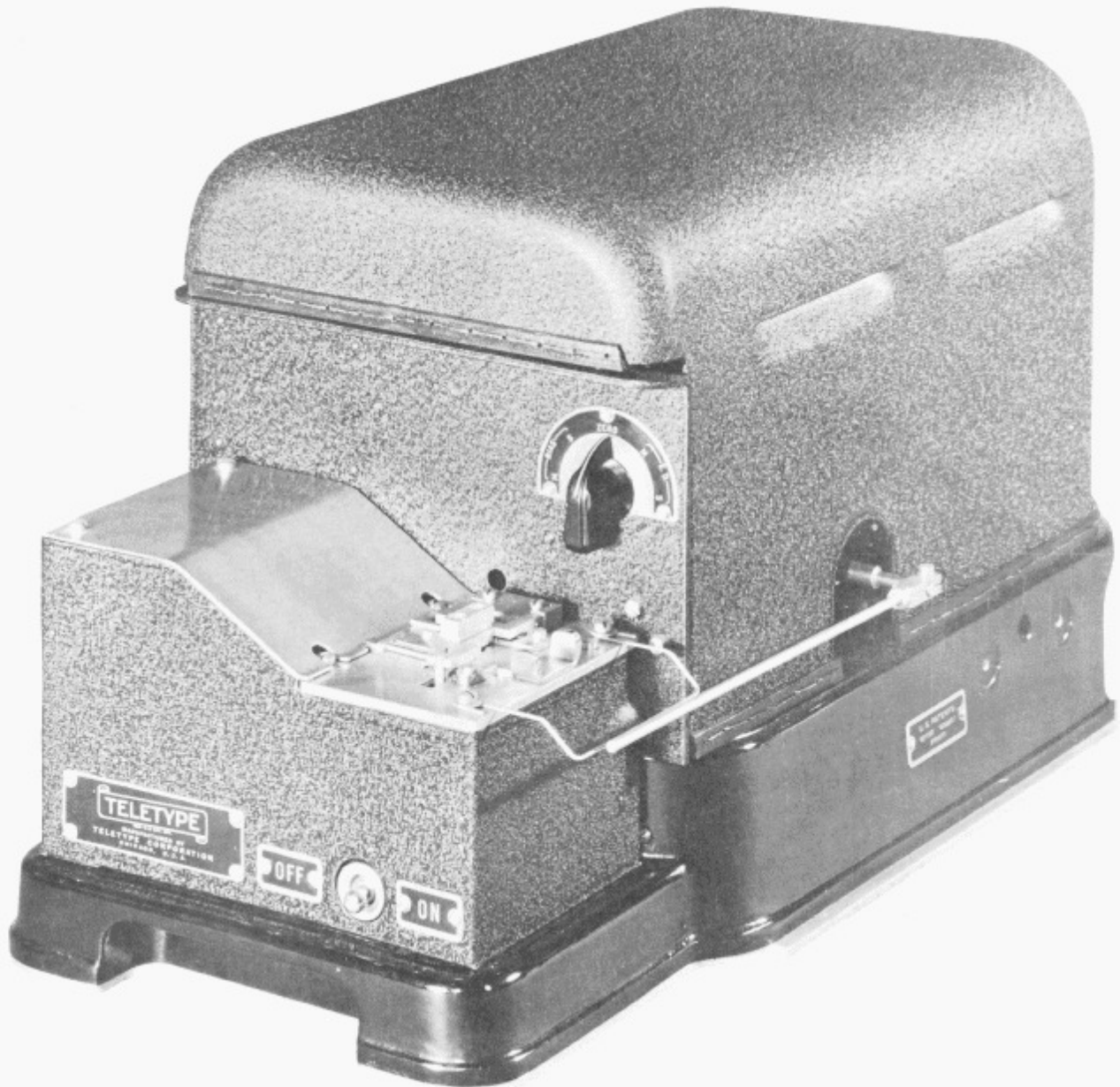

SIGNAL DISTORTION TEST SET

CONTENTS

Paragraph	Page	Paragraph	Page
SECTION 1 - DESCRIPTION		17. Rubout Deleting Mechanism	1-8
SECTION 1 - DESCRIPTION		SECTION 2 - ADJUSTMENTS	
1. General	1-1	1. General	2-1
a. Transmitter Distributors	1-1	2. Adjusting Procedure	2-1
b. Distributors	1-1	a. Distributor Proper	2-1
c. Two-Channel Start-Stop Transmitter Distributor	1-1	(1) "B" Transmitter Operating Lever	2-1
d. Signal Distortion Test Set	1-2	(2) Main Shaft	2-2
2. Theoretical Circuit	1-2	(3) Motor Position	2-2
3. Theoretical Transmitting Circuits	1-2	(4) Magnet Core	2-2
a. Transmitter Distributors and Signal Distortion Test Set	1-3	(5) Armature Plate	2-2
b. Distributor	1-3	(6) Stop Lever Pilot Screws	2-2
c. Signal Distortion Test Set	1-3	(7) Stop Lever and (Latch Lever) Pilot Screws	2-2
4. The Tape Sensing Mechanism	1-3	(8) Start Magnet Bracket	2-2
(1) For Transmitter Distributors	1-3	(9) Armature Lever Spring Tension	2-3
(2) For Distributors	1-4	(10) Stop Lever Spring Tension	2-3
5. Tape Sensing Mechanism	1-4	(11) Latch Lever Spring Tension	2-3
6. Distributor Mechanism	1-4	(12) Latch Lever Stop	2-3
7. Distributor Mechanism	1-5	(13) Reset Cam	2-3
8. Tape Feed Mechanism	1-5	(14) Clutch Shoe Lever	2-3
9. Starting and Stopping Transmission	1-5	(15) Clutch Shoe Spring Tension	2-4
a. Transmitter Distributor or Signal Distortion Test Set	1-5	(16) Clutch Shoe Lever Spring Tension	2-4
(1) Units equipped with friction clutch	1-5	(17) Gear Guard	2-4
(2) Units equipped with all metal clutch	1-6	(18) Operating Lever Spring Tension (100 WPM Operation)	2-4
(b) Clutch engagement	1-6	(19) Bail Spring Tension (100 WPM Operation)	2-4
(c) Clutch disengagement	1-6	(20) Tape Stop-Magnet Bracket	2-4
b. Two-Channel Start-Stop Transmitter Distributor	1-6	(a) Universal Magnet	2-4
c. Signal Distortion Test Set - Control Switch	1-6	(b) D. C. Magnet	2-4
10. Tight-Tape Stop Mechanism (Auto-Stop Mechanism)	1-6	(21) Stop-Arm Pilot Screws	2-5
11. Tape Stop Switch	1-7	(22) Stop-Arm Spring Tension	2-5
12. End-Of-Tape Stop Mechanism	1-7	(23) Stop Lever Pilot Screws	2-5
13. Bell-On-Blank Signal Mechanism	1-7	(24) Armature Backstop	2-5
14. Torn Feed Hole Tape Stop Mechanism	1-7	(25) Stop Magnet Contact	2-5
15. Synchronous and Governed Motors	1-8	(26) Tape Feed-Pawl Spring Tension	2-6
16. Filter Cutout Switch - Signal Distortion Test Set	1-8	(27) Detent-Lever Spring Tension	2-6
		(28) Feed Wheel Shaft Bearings	2-6
		(29) Tape Retaining-Lid Latch Wearing-Strip Shims	2-6
		(30) Tape Space	2-6
		(31) Tape Guide	2-6
		(32) Detent Bracket	2-7
		(33) Tape Retaining-Lid Plate	2-7
		(34) Retaining-Lid Latch Spring Tension	2-7
		(35) Feed-Lever Adjusting Screw	2-7
		(36) Operating-Lever Adjusting Screw	2-7

CONTENTS (Cont'd.)

<u>Paragraph</u>	<u>Page</u>	<u>Paragraph</u>	<u>Page</u>
(37) Contact Tongues Alignment	2-7		
(38) Feed-Lever Stop	2-8		
(39) Tape Transmitter Contacts	2-8		
(40) Lower Contact Screw	2-8		
(a) For Units Designed to use Chadless Tape	2-8		
(b) For Units Designed to use Regular Tape Exclusively	2-8		
(41) Upper Contact Screw	2-8		
(42) Contact-Lever Spring Tension	2-8		
(43) Contact Lever Movement	2-8		
(44) Feed-Lever Spring Tension	2-9		
(45) Tight-Tape-Stop or Auto-Stop Mechanism	2-9		
(46) Distributor Brushes	2-10		
1. Carbon Brush	2-10		
2. Braided Brush - Low Brush Arm	2-11		
3. Braided Brush - High Brush Arm	2-11		
BREAK-LOCK MECHANISM ADJUSTMENTS			
(47) Mounting Plate	2-11		
(48) Magnet Bracket	2-11		
(49) Magnet Core	2-12		
(50) Shunt Contact	2-12		
(51) Shunt Contact Bracket	2-12		
(52) Push Rod Lock	2-12		
(53) Break Contact	2-12		
(54) Make Contact	2-12		
(55) Contact Pawl Spring Tension	2-12		
(56) Shunt Contact Lever Spring Tension	2-12		
(57) Armature Lever Spring Tension	2-12		
(58) Armature Lever Spring	2-13		
END OF BREAK-LOCK MECHANISM ADJUSTMENTS			
(59) Operating Cam	2-13		
(a) Transmitter Distributors and Signal Distortion Test Set	2-13		
(b) Distributors	2-13		
(c) Two-Channel Units	2-14		
(59.1) Tape Lockout Solenoid	2-14		
(60) Control Relay Timing Contacts	2-14		
(61) Transmitter, Operating Lever Spring Tension	2-14		
(62) Lock Pawl ("A" and "B" Transmitters)	2-14		
(63) Line Shorting Contact			
		("A" and "B" Transmitters)	2-14
		(64) Line Shorting and Transfer Contact Adjustments ("A" and "B" Transmitters)	2-15
		(65) Transmission Control Relay Switch Lever Pivot Plate	2-15
		(66) Send-Stop Lever Spring Tension ("A" and "B" Transmitters)	2-16
		(67) Transmission Control Relay Switch Lever Pivot Plate	2-16
		(68) Send-Stop Lever Spring Tension	2-16
TRANSMISSION CONTROL RELAY ADJUSTMENTS			
		(69) Contact Springs and Armature Hinge Positions	2-16
		(70) Adjusting Stud Clearance	2-16
		(71) Adjusting Nut Tightness	2-16
		(72) Armature Travel	2-17
		(73) Contact Spring Tension	2-17
		(74) Stud Gap	2-17
		(75) Contact Sequence	2-17
		(76) Contact Make	2-17
END OF TRANSMISSION CONTROL RELAY ADJUSTMENTS			
		(77) Main Shaft Clutch Torque	2-18
		(a) Transmitter Distributor	2-18
		(b) Distributor	2-18
		(c) Signal Distortion Test Set	2-18
RUBOUT DELETING MECHANISM ADJUSTMENT			
		(78) Rubout Ball Position	2-19
		(79) Control Assembly Contact Spring Clearance and Tension	2-19
		(80) Control Assembly Cam Follower Position	2-19
		(81) Control Assembly Position	2-19
		(82) Rubout Lever Mounting Bracket	2-19
		(83) Rubout Lever Adjusting Bracket	2-19
		(84) Rubout Contact	2-19
		(85) Rubout Contact Assembly	2-19

CONTENTS (Cont'd.)

<u>Paragraph</u>	<u>Page</u>	<u>Paragraph</u>	<u>Page</u>
(86) Control Relay	2-19	(110) Contact Operating-Lever Spring Tension	2-24
(87) Rubout Bail Spring Tension	2-20	(111) Break-Relay Armature Yoke	2-24
(88) Intermediate Lever Spring Tension	2-20	(112) Residual Screw	2-24
(89) Control Switch	2-20	(113) Break-Relay Contact	2-24
(90) Control Switch Contact Spring	2-20	(114) Armature Arm	2-24
(91) Signal Distortion Calibration	2-20	(115) Armature Arm Backstop	2-24
END-OF-TAPE STOP MECHANISM ADJUSTMENTS		END OF BELL-ON-BLANK ADJUSTMENTS	
(92) End-Of-Tape Stop- Contact-Pin Guide	2-21	(116) Stop-Arm Contact Spring Tension	2-25
(93) End-Of-Tape Stop- Contact-Spring	2-22	(117) Stop-Arm Contact Gap	2-25
SINGLE STEP TAPE FEED SUPPRESSION MECHANISM ADJUSTMENTS		TORN FEED HOLE TAPE STOP ASSEMBLY ADJUSTMENTS	
(94) Tape Feed Lever Latch	2-22	(118) Feed Wheel Shaft Bearings	2-25
(95) Trip-Off Latch Eccentric	2-22	(119) Detent Lever Spring Tension	2-25
(96) Restoring Lever Eccentric	2-22	(120) Tape Retaining Lid Latch Wearing Strip Shims	2-25
(97) Restoring Lever Plate	2-22	(121) Tape Space	2-25
(98) Trip-Off Lever Spring Tension	2-22	(122) Tape Finger	2-25
(99) Non-Repeat Lever Spring Tension	2-22	(123) Tape Retaining Lid Plate	2-25
(100) Tape Feed Lever Latch Spring Tension	2-23	(124) Tape Guide	2-25
(101) Restoring Lever Spring Tension	2-23	(125) Retaining Lid Latch Spring	2-25
(102) Trip-Off Latch Spring Tension	2-23	(126) Detent Bracket	2-25
(103) Restoring Bail Spring Tension	2-23	(127) End-of-Tape Stop Con- tact Spring	2-25
END OF SINGLE STEP TAPE FEED SUPPRESSION MECHANISM ADJUSTMENTS		(128) Operating Instructions	2-25
(104) Tape Guide Wire	2-23	EXTERNAL CIRCUIT CONTROL CONTACT MECHANISM ADJUSTMENTS	
BELL-ON-BLANK SIGNAL MECHANISM ADJUSTMENTS		(129) Contact Spring Tension	2-26
(105) Contact Operating-Lever Latch	2-23	(130) Contact Clearance	2-26
(106) Contact Operating-Lever Bracket	2-23	(131) Operating Lever Spring Tension	2-26
(107) Contact Operating-Lever Latch Overtravel	2-23	b. Synchronous Motors - Starting Switch	2-26
(108) Contact	2-23	c. Governed Motors	2-26
(109) Bell-On-Blank	2-24	(1) Motor Armature Thrust Spring Compression	2-26
		(2) Governor Shell	2-27
		(3) Governor	2-27
		(a) Alignment and Square- ness of Governor Contacts	2-27
		(b) Speed-Adjusting-Wheel Friction Washer	2-27
		(c) Speed-Adjusting-Lever Stop Plate	2-27
		(d) Governor Shims	2-27
		(e) Speed Setting	2-27

CONTENTS (Cont'd.)

<u>Paragraph</u>	<u>Page</u>	<u>Paragraph</u>	<u>Page</u>
(4) End-Ring Governors	2-28	(d) Governor Guard	2-28
(a) Inner and Outer Disk Contact Spring	2-28	(5) Peripheral-Ring Governors	2-28
(b) Governor-Brush Spring-Plate Bracket	2-28	(a) Governor-Brush Bracket	2-28
(c) Governor-Brush Spring Pressure	2-28	(b) Governor-Brush Spring Tension	2-28

SECTION 3 - LUBRICATION

SECTION 1

DESCRIPTION

1. GENERAL

a. TRANSMITTER DISTRIBUTOR (Figure 1)

(1) The transmitter distributor is a motor driven device which translates code combinations, perforated in a paper tape, into electrical impulses and transmits these impulses to one or more receiving stations. The tape may be perforated by any one of several models of Teletype perforating or re-perforating machines.

(2) There are two kinds of transmitter distributors; one for transmitting five unit code, and the other for transmitting six unit code. These two kinds are identical except that the six unit code machine accommodates a wider tape and provides for the transmission of an additional impulse. The following description pertains specifically to the five unit transmitter distributor.

b. DISTRIBUTORS

(1) The distributors described herein are motor driven devices, which translate code combinations from fully perforated or chadless tape into electrical impulses. These impulses (set up locally) are combined with impulses from an external source and these combined signals are used in printing telegraph transmitting or receiving circuits.

(2) As the tape automatically feeds through the sensing mechanism, the tape pins sense the perforations in the tape and thereby determine the positions of the contact tongues with relation to the upper or lower contact screws. The signals received on the distributor segments are routed through the contact tongues to either the upper or lower contacts depending upon the selected combination in the tape.

(3) The distributor combines the impulses from the local and external source and completes the connection to the signal line. Connections are made in sequence at a uniform rate of speed by the brushes which traverse the segments and collector rings.

c. TWO-CHANNEL START-STOP TRANSMITTER DISTRIBUTOR

(1) The Teletype two-channel start-stop transmitter distributors herein described are motor driven units that utilize the circuit in such a manner as to provide two-channel transmission of messages from two separate per-

forated tapes (either chadless or fully perforated) at 368 o. p. m. per channel. When conditions do not warrant two-channel transmission, the unit may be operated as a single channel transmitter distributor.

(2) Since the frequency of the transmitted impulses at 368 o. p. m. is 23 cycles per second for single channel operation, and 46 cycles for two-channel, consideration should be given to the characteristics of the circuit on which the unit is to be used.

(3) At receiving stations, standard start-stop printers or re-perforators connected in series may be used. It is recommended that these units be equipped with holding magnet selectors to provide maximum orientation range. Signals from "A" channel will be recorded on its respective receiving unit when the index arm of the range finder is oriented to the most favorable position on the upper portion of the range scale. Signals from "B" channel will be recorded on its respective receiving unit when the index arm is oriented to the most favorable position on the lower portion of its range scale.

(4) Where Teletype units with selectors of the pulling magnet type are used at receiving stations, or where it is desirable to use spare receiving units interchangeably on all channels, without reorientation, it is suggested that a pair of Teletype regenerative repeater units be connected in series with the line and that each be oriented to its respective channel. The regenerative repeater units, being equipped with the holding magnet feature, provide maximum orientation range for two-channel operation. The regenerated impulses relayed to the receiving units will be of the required length to provide normal orientation range for the selectors. This arrangement facilitates the interchange of receiving units between associated start-stop channels and circuits.

(5) Two transmitter distributors are available which differ as follows:

(a) Transmits BLANK combination when one channel only is idling.

(b) Transmits LETTERS combination when one channel only is idling.

(6) These two-channel transmitter distributors (Figure 2) each include two tape sensing and transmitting mechanisms and a special distributor commutator having five pairs of segments for the transmission of intelligence

impulses, a start segment, a stop segment, and an "X" segment located between the start and stop segments. Since no distributor clutch is provided, the distributor brushes rotate continuously with the motor. The present arrangement requires fully attended service in which the operator inserts the message tape and starts and stops the transmitters manually. No tight-tape or end-of-tape stop mechanisms are being provided. A switch lever, located on the lower front portion of the unit, switches the distributor circuits in preparation for either single channel or two-channel operations. A send-stop lever associated with each transmitter controls transmission on individual channels. During single channel operation, the "A" channel transmitter only can be used. A toggle switch controls the starting and stopping of the motor.

d. **SIGNAL DISTORTION TEST SET** - The signal distortion test set is a motor driven mechanism designed to transmit signals which are distorted by either bias or end distortion. It is used for the purpose of determining the efficiency of start-stop selectors on Teletype apparatus. In all other respects it is similar to the Model 14 Transmitter Distributor.

NOTE

In all the figures of this bulletin, end views of fixed pivot points are designated by solid black circles.

2. THEORETICAL CIRCUIT - See Note (1) on Page 2-1

a. Interposed in the circuits between the transmitter tongues and the distributor code segments are the contacts of the transmission control relay (Figure 3). This relay is under the control of the switch lever located on the lower front portion of the unit. With the relay energized (switch lever thrown to left), its contacts connect the five tongues of the "B" channel transmitter to the "B" segments of the distributor. The tongues of the "A" channel transmitter are directly connected to the "A" segments. Parallel paths from the "A" tongues lead to open contacts on the relay. Under these conditions, the rotating distributor brush will alternately connect "B" and "A" channel transmitter tongues to the signal line thus providing two-channel transmission. The code impulses transmitted will depend on the positions of the transmitter tongues with relation to their upper and lower contact screws. The lower contact screws of each transmitter are permanently connected to marking line battery. No battery is applied to the upper contact screws when the transmitters are sending neutral telegraph impulses. Spacing battery is applied to these contact screws when sending polar impulses. Means is provided for switching the up-

per contacts of each transmitter on certain units to marking battery when idling. The stop segment is permanently connected to marking battery; the start segment to the spacing battery lead. The center solid ring of the distributor is connected to the signal line. During two-channel transmission, the relay contacts connect the "X" segment to the stop segment. The start and stop impulses then transmitted are effective on both channels. The signal line frequency will be doubled due to intelligence impulses being one-half their normal length, and selectors of receiving units will register corresponding reductions in orientation range.

b. With the transmission control relay de-energized (switch lever thrown to right), the "B" transmitter tongues are disconnected from the "B" segments and the "A" and "B" segments of each pair are electrically joined through the contacts of the relay. The "X" segment is switched from the stop to the start segment. This lengthening of the start segment causes an upward shift of the orientation range with reference to the range scale on receiving units. The "B" channel receiving unit will be out of range and the normal single channel impulses then transmitted will be presented to the "A" channel receiving unit, so timed, that a change in the index arm position should be unnecessary.

c. When the send-stop lever of a transmitter is placed in the stop position, the BLANK or LETTERS (whichever unit is used) combination is repeatedly transmitted on the respective channel, provided that one channel only is idle. With both send-stop levers in the stop position, line-shorting contacts associated with these levers unite to close a line-shorting circuit which shunts the distributor segments and connects marking battery directly to the signal line to prevent the transmission of impulses during idle rotations of the brush. A set of control relay timing contacts located in the circuit leading to the transmission control relay winding, and actuated by mechanism associated with the main shaft, prevents channel switching except during the time in which the brush is traversing the stop segment.

d. Units that transmit the LETTERS combination are equipped with two sets of transfer contacts which are actuated by the send-stop levers. With a send-stop lever in the stop position, these contacts apply marking battery to the upper contacts of the associated transmitter (or switch the contacts from spacing to marking battery in the case of polar transmission) causing the LETTERS combination to be continuously transmitted on the idle channel.

3. THEORETICAL TRANSMITTING CIRCUITS - See Note (G) on Page 2-1

a. **TRANSMITTER DISTRIBUTORS AND SIGNAL DISTORTION TEST SET** - The portion of the unit through which the perforated tape feeds is known as the transmitter (Figure 4). The transmitter prepares electrical paths from the signal line battery to the commutator segments of the distributor. (See Figure 5). These paths are controlled by tape pins which sense the perforations in the tape and thereby determine the positions of the contact tongues (Fig. 6) with relation to their upper and lower contact screws.

b. **DISTRIBUTOR** - The distributor (Figure 4) completes the connections to the signal line. Connections are made in sequence at a constant rate of speed by brushes which traverse the segments and the collector ring.

c. **FOR SIGNAL DISTORTION TEST SET** - The commutator distributor completes the connection between the commutator segments and the signal line in the proper sequence and at a given and constant rate of speed. This is accomplished by brushes which are drawn across the segments by the distributor brush arm attached to the distributor shaft. The brush arm supports two sets of brushes: one pair of brushes makes contact with the inner solid collector ring and the segments of the stationary ring; the second pair of brushes makes contact with the remaining solid collector ring and the segments mounted on the movable ring. The latter brushes and rings are used alone for normal signal transmission but both sets of brushes and rings are used for the transmission of distorted signals by making various combinations of electrical connections between the segments and rings.

4. THE TAPE-SENSING MECHANISM - See Notes (F) and (G) on Page 2-1.

a. The tape-sensing mechanism consists essentially of a group of five similar contact levers (Figure 6) with associated contact tongues, a contact block with five pairs of contact screws (five marking and five spacing), and a group of parts consisting of a contact lever bail, operating lever and roller, and operating cam (Figure 7).

b. The five contact levers (Figure 6) are positioned vertically in the transmitter and all pivot on the same shaft S. Each contact lever has three irregularly shaped extensions - to the left A, downward B, and to the right C. Extension C projects upward at the end and has a small tape pin embedded vertically into the end of the extension. An opening is provided in a tape guide, located above the right-hand extension C of the contact lever, to permit the tape pins to enter the code holes in the tape. The left-hand extension A has a contact tongue assembly attached to it by a pivotal mounting. Each contact

tongue is positioned to move between two contact screws, a spacing contact screw above, and a marking contact screw below. A contact-lever spring is attached to the mounting end of each contact and tends to hold it against the lower contact screw. Extension B extends vertically downward and engages the contact-lever bail.

c. A contact-lever bail, pivotally mounted just below contact lever lower extensions, has an arm which extends downward and engages a transmitter operating lever. This transmitter operating lever (Figure 7) has a central pivot screw and moves in a horizontal plane. A roller on the rear end of the lever rides a transmitter operating cam mounted on the lower end of the distributor (main) shaft. The motion imparted to the transmitter operating lever by the operating cam causes the contact lever bail to rotate the contact levers on their shafts sufficiently to move the contact tongues up and down between the marking and spacing contact screws. After the tongues strike the upper screws, any additional clockwise rotation of the contact levers is absorbed by the contact lever springs.

(1) For Transmitter Distributors - When the distributor brush comes to rest on the stop segment (Figure 4), the transmitting operating-lever roller is on the peak of its cam. This position of the operating-lever roller, through the medium of the operating lever and the contact lever bail, holds the contact levers in such a position that the tape pins are below the upper surface of the tape guide, and the contact tongues rest against the spacing (upper) contact screws.

(2) For Distributors - When the main shaft is stopped (lug on stop cam against the end of stop lever) (Figure 8) the contact tongues are held against the spacing or upper contact screws and the tape pins mounted on the right-hand extensions of the contact levers are held below the holes in the tape.

d. As the operating lever roller rides to the low part of its cam, the tape pins rise. If tape perforated with code combinations is in the tape guide at this time, the contact lever pins will project through the tape wherever the tape is perforated and permit the associated contact tongues to rest on the marking contacts (lower contact screws), while the pins will be blocked at the unperforated portions and the associated contact tongues will be held against the spacing contacts (upper contact screws).

(1) For Transmitter Distributors

(a) The tape will be held stationary and the contact tongues will maintain their positions as determined by the code perforations while the distributor brush is traversing seg-

ments one to five inclusive. The inner distributor brush will transmit marking impulses to the line from segments associated with tongues that rest on the lower contacts, and spacing impulses (for polar signal transmission) from segments associated with tongues that are on the upper contacts. When "make-break" signal transmission is used (battery applied only to the lower contacts), a no-current interval occurs when the contact tongues are against the spacing contacts.

(b) When a message on chadless tape is inserted in the tape guide, with the printed symbol of the character to be transmitted positioned opposite the tape locating mark impressed in the tape guide, the code perforation for that character will be over the tape sensing pins in position for transmission. Under this condition, if the tape retainer of the transmitter distributor is fastened over the tape, the tape locating mark will be covered, but the printed character will be visible immediately to the right of the tape retainer.

(2) For Distributors - The tape will be held stationary and the contact tongues will maintain their positions as determined by the code combinations perforated in the tape while the distributor brushes are traversing the segments and collector ring. The inner brush picks up signals from the line and the outer brush distributes them to their proper segments which, in turn, are connected to their corresponding contact tongue.

5. TAPE SENSING MECHANISM - See Note (1) on Page 2-1

a. The contact levers (Figure 6) are positioned vertically in the two transmitters. Each contact lever pivots on a shaft and has a tape pin located at the extremity of its right-hand extension which projects upward through an opening in the tape guide and senses the code holes in the tape. A contact tongue, which moves vertically between two contact screws (upper - spacing, and lower - marking) is attached to the left-hand extension of each contact lever by a pivotal mounting. A contact lever spring attached to the mounting end of each contact tongue tends to hold the tongue against the lower contact screw.

b. Each of two transmitter contact lever balls, pivotally mounted just below the contact lever lower extension, has an arm extending downward (Figure 6). One arm engages the "A" transmitter operating lever and the other engages the "B" transmitter operating lever (Figure 9). A cam on the lower end of the main shaft imparts motion to "A" and "B" transmitter operating levers which are linked together. This motion causes the contact lever bail to rotate the contact levers on their shaft sufficiently to move the con-

tact tongues up and down between the marking and spacing contact screws. After the tongues strike the upper screws, any additional clockwise rotation of the contact levers is absorbed by the contact lever springs.

c. When the distributor brush is on the stop segment, the transmitter operating lever roller is on the peak of its cam, thereby holding the tongues against the SPACING contact screws and also holding the tape pins, located in the right-hand extensions of the contact levers, below the holes in the tape (see Figure 6). As the transmitter operating lever roller (Figure 9) rides to the low part of its cam, the tape pins rise. If the tape perforated with code combinations is in the tape guide at this time, the contact lever pins will project through the tape wherever the tape is perforated, and will permit the associated contact tongues to rest on the MARKING contact screws. Contact lever pins that are blocked by the unperforated portions of the tape will cause the associated contact tongues to be held against the SPACING contact screws. The tape will be held stationary and the contact tongues will maintain their positions as determined by the code perforations while the distributor brush is traversing segments B-1 and A-5 inclusive. The distributor brush will transmit MARKING impulses to the line from segments associated with tongues that rest on the lower contact screws, and SPACING impulses for polar transmission) from segments associated with tongues that are against the upper contacts. If "make-break" transmission is used (battery applied to the MARKING contact screws only), a no-current interval occurs when the brush traverses segments associated with contact tongues that are against SPACING contact screws.

6. DISTRIBUTOR MECHANISM - See Note (G) on Page 2-1

a. The distributor mechanism consists of the distributor disk and the distributor brush assembly.

b. The distributor (Figure 4) is made up of two concentric conducting rings mounted on an insulated disk. The outer ring is divided into seven segments. The inner ring is a continuous conductor. Segment Nos. 1 to 5, inclusive, of the outer ring, correspond to the five intelligence intervals of the five unit code and are connected to the five contact tongues. Immediately preceding No. 1 Segment is the start segment. The segment following No. 5 Segment is the stop segment. The stop segment and the lower contact screws are permanently connected to marking line battery. The start segment and the upper contact screws are connected to spacing line battery only when it is desired to transmit polar signals; otherwise, the upper contact screws and the start segment have no battery connections.

c. The distributor brush assembly consists of a pair of brushes clamped in a metal brush holder. The brush holder is attached to the brush holder arm, which is mounted on the upper end of the main shaft. The brushes are spaced in the brush holder the same distance apart as the concentric rings on the distributor disk and revolve with the main shaft. The brush assembly makes one complete revolution to transmit the code combination for each character or function. When the distributor brush passes over the start segment, a spacing impulse is always transmitted, whereas a marking impulse always results when the brush traverses the stop segment. These two invariable impulses cause the receiving mechanism to operate in unison with the distributor brush arm.

7. DISTRIBUTOR MECHANISM (FIGURE 8) - See Note (F) on Page 2-1

a. The distributor brush arm is mounted on the upper end of the main shaft and is driven by a gear through the medium of a friction clutch.

b. The distributor commutator is made up of two concentric conducting rings mounted on an insulated disk. The outer ring is divided into five large and ten small segments. The inner ring has two segments; one is a small segment and the other a large segment which forms the most of the ring. The brushes on the brush arm wipe over the rings, thereby connecting the inner segments to the outer segments.

c. In the normal unoperated position, the main shaft is held stationary, because the lug of the stop cam is against the end of the stop lever. Under this condition, the brush arm is positioned so that the one brush rests on the large inner ring segment and the other brush is on one of the small segments to the left of the stop segment on the outer segment ring.

d. When the start impulse is received, positive battery is applied to the operating magnet coils through the large inner ring segment and the small segment on the outer ring.

e. This will energize the operating magnet coils so that the stop lever is unlatched from the armature extension and is held out of the way of the lug on the stop cam, permitting the main shaft to rotate.

f. When the brush reaches the start segment, it closes a path to transmit a start or positive battery signal. When the brush reaches the No. 1 Segment, the line signal will be connected to the No. 1 Contact Tongue. The same procedure takes place when the brush reaches the Nos. 2, 3, 4, and 5 Segments on the outer ring.

g. When the brush reaches the stop segment on the outer ring, negative battery is applied to the stop segment from the small segment on the inner ring.

h. When the brush reaches the rest segment on the outer ring, the stop lever is latched on the operating armature extension by means of the reset extension of the stop lever which rides on the lug on the stop cam, resetting the stop lever so it will be latched during the time the operating magnet armature is in its unoperated position.

8. TAPE FEED MECHANISM

Positioned to the rear of the contact levers and pivoted on the contact lever shaft is a feed lever (Figure 11) which is similar in shape to a contact lever. The feed lever has a spring attached to its left-hand extension and a feed pawl mounted on its right-hand extension C. A feed pawl spring holds the feed pawl in contact with a feed wheel ratchet. Pins on the circumference of the feed wheel (Figure 6) project through an opening in the tape guide and mesh with the feed holes in the tape. A retaining lid, under which the tape passes, holds the tape in contact with the feed wheel pins. When the action of the contact lever bail on the contact lever moves the tape pins downward, the feed lever responds in similar manner, causing the feed pawl to engage a tooth on the feed wheel ratchet and rotate the feed wheel. With each downward motion of the feed pawl, the tape will be advanced from right to left, the distance required to bring the succeeding code combination over the tape pins. The setting of the feed pawl is such that it does not start to rotate the feed wheel until the tape pins have moved clear of the tape. A feed wheel detent is provided to insure alignment of the code perforations with the tape pins. The position of the operating cam with relation to the distributor brush is such that the contact tongues are not moved from the lower contacts until after the brush has reached the stop segment. While the brush is passing over the stop segment, the tape is advanced.

9. STARTING AND STOPPING TRANSMISSION

a. TRANSMITTER DISTRIBUTOR OR SIGNAL DISTORTION TEST SET

(1) Units Equipped with Friction Clutch - The main shaft is driven by a motor through the medium of gears and a friction clutch. When the motor is running, transmission is stopped by blocking the rotation of the main shaft and started by unblocking it. This is done through the medium of a stop arm which is under the control of a tape stop magnet and a spring. (Figure 4). The magnet, when energized, holds the

stop arm clear of the lug. The spring holds the stop arm in the path of the lug when the magnet is de-energized. The circuit to the magnet is controlled by two pairs of contacts and a switch which are in series with the magnet and the power supply. See paragraphs 10, 11, and 12.

(2) Units Equipped with All Metal Clutch

(a) With the start magnet de-energized, the stop lever engages the shoe release lever which permits the clutch shoes to withdraw from the clutch drum. The clutch drum, gear and gear bearing are then free to rotate with the motor pinion while the main shaft remains stationary. A latch lever drops in a notch in the stop disk and prevents oscillation of the disk. Energization of the start magnet causes the stop lever to release the clutch shoe release lever. The release lever causes the clutch shoes to engage the drum so that the entire clutch assembly rotates. Since the disk is attached to a disk bearing on the main shaft, the shaft rotates with the clutch.

(b) Clutch engagement (Figure 10) is accomplished by releasing the lower end of lever B. The upper end of lever B pivots about its ear C (which bears against the upper end of the secondary shoe) and moves its ear D, and the upper end of the primary shoe, toward the left until the shoe makes contact with the drum at point E. As the drum turns counterclockwise, it drives the primary shoe downward, so that it again makes contact with the drum, this time at point F. There, the combined forces acting on the primary shoe cause it to push against the secondary shoe at point G. The lower end of the secondary shoe then bears against the drum at point H. The revolving drum acts to drive this shoe upward so that it again makes contact with the drum at point I. Since the forces involved are multiplied at each succeeding step, the final force developed at point I is very great. This force is applied to the lug J on the clutch cam disk to cause it to turn in step with the drum. The cam disk on the clutch is connected to the cam shaft imparting rotary motion to the cam assembly.

(c) Clutch disengagement (Figure 10) is accomplished by bringing together lug A on the clutch cam disk, and the lower end of the clutch shoe lever B. The upper end of lever B pivots about its ear C and allows its other ear D to move toward the right. The upper spring then pulls the two shoes together and away from the drum.

(3) The circuit to the magnet may be opened or closed by means of the tight-tape stop contacts, tape stop contacts, tape stop switch, or the end-of-tape stop mechanism contacts

which are described in paragraphs 10, 11 and 12 that follow.

b. TWO-CHANNEL START-STOP TRANSMITTER DISTRIBUTOR

(1) The main shaft is geared directly to the motor and rotates continuously when the motor switch (see Figure 2) is in the ON position.

(2) Each send-stop lever (Figure 2) in addition to actuating its associated contacts, controls a locking pawl which blocks the action of the contact lever bail (Figure 11), when the send-stop lever is in its stop position. With the contact lever bail blocked in this manner, the tape pins are held depressed and the contact tongues rest against the spacing contacts.

(3) The control relay switch which is in series with the windings of the transmission control relay is operated by means of the switch lever which projects from the front of the unit.

c. SIGNAL DISTORTION TEST SET - CONTROL SWITCH - The changes in connections required for the transmission of signals with various types of distortion are handled by a single switch mounted on the vertical panel above the hinged tape lid. Reading clockwise, the positions of the control switch and a brief explanation of the character of the signals obtainable at each setting of the switch are as follows:

(1) Marking bias which advances the beginning of each marking impulse with respect to the beginning of the character cycle.

(2) Spacing bias, which delays the beginning of each marking impulse.

(3) Zero distortion or normal signal transmission.

(4) Marking end distortion which delays the end of each marking selecting impulse.

(5) Spacing end distortion which advances the end of each marking selecting impulse.

10. TIGHT-TAPE STOP MECHANISM (AUTO-STOP MECHANISM)

When the slack in the tape between the tape perforator and the transmitter is taken up, the tape raises the tight-tape stop lever which opens the circuit to the tape stop magnet through the tight-tape contact and allows the stop arm to engage the lug on the stop cam (Figure 4). A tape guide wire may also be employed to guide slack tape within close proximity of the tight-tape stop lever so as to raise the lever and stop

transmission if the tape feeding into the transmitter becomes tangled, thus preventing mutilation of the tape feed wheel perforations.

11. TAPE STOP SWITCH

Transmission can also be stopped by manually operating the tape stop switch (Figure 4). The switch controls the release magnet in a manner similar to that of the mechanism described in the preceding paragraph.

NOTE

On some types of distributors, this switch is connected in the motor circuit and is then used to start or stop the motor.

12. END-OF-TAPE STOP MECHANISM

Another means may be provided for automatically stopping transmission when a length of tape has passed through the transmitter. This is accomplished by another pair of contacts located beneath the tape guide which are operated by a pin that projects through the tape guide (Figure 4). When the tape retaining lid is closed, the end-of-tape stop pin is depressed and the contacts are held closed so long as there is tape between the pin and the lid. When the end of the tape passes the pin, the tension of the contact spring raises the pin and opens the contacts, and stops transmission.

13. BELL-ON-BLANK SIGNAL MECHANISM

a. The transmitter distributor may be equipped with bell-on-blank signal mechanism for use when the receiving printers associated with the transmitter distributor on the circuit are equipped to select the bell signal on the blank combination.

b. The bell-on-blank signal mechanism consists of a slow acting break relay, a set of contacts, and a contact operating lever. This mechanism enables the operator to send a blank signal while a perforated tape is in the transmitter. This is accomplished by allowing the commutator brush to rotate while the contact tongues that transmit the code are held against the spacing contact, and the transmitter operating lever is prevented from following the operating cam (Figure 12). When it is desired to send a blank signal, the tape stop lever should be lifted and the contact operating lever should be moved manually to the operated position, once for each blank signal.

c. When the contact operating lever is operated, a latch engages the transmitter operating lever and prevents the latter from following the transmitter operating cam. This causes the

contact tongues to remain against the spacing contacts and also prevents feeding of the tape. At the same time that the transmitter operating lever is being latched, a finger on the contact operating lever closes contacts "A" and "B" (Figure 13). The closing of contacts "A" and "B" connects the tape stop magnet in parallel with the winding of the break relay (break relay contacts closed) and applies battery to both parallel circuits. The circuit of the tape stop magnet is in series with contact "C" of the break relay. The slow acting break relay responds more slowly to the closing of its circuit than the tape stop magnet, thereby allowing time for the tape stop magnet to operate the stop arm and the commutator brush to start rotating before contact "C" opens. Before the commutator brush has completed one revolution, however, the slow acting relay will have opened contact "C" causing the tape stop magnet to release the stop arm which will stop the commutator brush at the end of the revolution. If the contact operating lever is held operated, the break relay will remain energized, thus holding contact "C" open. Additional blank signals may be transmitted by releasing and reoperating the contact operating lever.

14. TORN FEED HOLE TAPE STOP MECHANISM (Figure 14)

a. The downward motion of the feed pawl rotates half of the contact operating cam (Figure 14) through the medium of the feed roll gear and the contact operating cam gear; it also advances the perforated tape (tape feed holes mesh with the feed roll pins). The motion imparted to the tape rotates the feed wheel (feed wheel pins mesh with the feed holes in the tape) which rotates the other half of the contact operating cam (through the medium of the spring clutch). This half of the cam may also be rotated by movement of the reset wheel through its spring clutch.

b. In the reset position, the notches in each half of the contact operating cam are out of alignment, the contact operating cam arm (Figure 14) is held on the outer periphery of the cams and keeps the tape-out contacts of the transmitter distributor closed.

c. If the feed holes are torn, the tape no longer transmits the motion to the feed wheel. This causes one-half of the cam to rotate and the other half to remain stationary until the notches in the cams are in line, at which time both cams rotate together until the contact operating arm cam follower falls in the aligned notches opening the tape-out contacts to stop transmission. After tape has stopped due to torn feed holes, transmission is stopped after 3 to 15 repeat characters. After transmission has stopped due to

torn feed holes or end of tape, mechanism must be manually reset before transmission can be resumed.

15. SYNCHRONOUS AND GOVERNED MOTORS

a. Where regulated A. C. power is available, a synchronous motor may be used, otherwise governed motors must be used. Governed motors are available for operation on either A. C. or D. C. The speed is controlled by a centrifugal contact mechanism having commutator rings or disks. In general, motors are mounted directly to the base casting and the resistors and condenser used with governed motors are mounted on the base and in base cavity. However, some governed motors are mounted to a base plate having governor resistors and a condenser on it as to form a complete motor unit assembly.

b. When an A. C. governed motor is used, a contact assembly is provided which is operated by the tape stop magnet stop arm (Figure 15). The purpose of the contact assembly is to provide better speed control by introducing a resistor in series with the motor when the distributor shaft is rotating, and by shunting the resistor when the load of the friction clutch is added to the motor.

16. FILTER CUTOFF SWITCH - SIGNAL DISTORTION TEST SET

A toggle switch is provided in the left wall of the base casting to disconnect the radio filter from the signal line during calibration periods to prevent signal distortion due to the filter.

17. RUBOUT DELETING MECHANISM

a. The rubout deleting mechanism is an automatic electromechanical device which when installed on a six unit transmitter distributor

will maintain a marking signal line condition during the time a "rubout" code combination (all six holes perforated) would normally be transmitted. It thereby holds any selector which may be operated by this transmitter in a marking position during the time the rubout character is at the transmitter sensing pins. Consequently the rubout signal is not transmitted.

b. During transmission of any character, the presensing bail pins (Figures 60 and 66) sense the tape perforations of the following character. The presensing bail is blocked by the tape (See Figure 60) on all except the rubout combination. With this particular combination the presensing pins are spring driven up through the six perforated holes by the rubout bail spring (Figure 66) and simultaneously the bail pivots allowing its lower extension to close the presensing contacts (Figures 60 and 64), energizing the control relay (Figure 63). When the control relay is energized, it closes its two sets of contacts (Figure 65). The control assembly contacts are closed by the control cam (See Figure 62) as the distributor brush reaches the beginning of the stop segment and before the presensing contacts open. One control assembly contact in series with one of the control relay contacts (See Figure 65) will provide a circuit to hold the relay energized after the presensing contacts open. The remaining contacts in each assembly (control relay and control assembly) combine in series to provide marking battery to the distributor start segment until the distributor brush is at the end of the No. 2 segment. By this time the tape has advanced and the regular sensing pins are responding to the rubout combination perforations in the tape maintaining a marking signal line condition until the start pulse of the next character.

c. This mechanism operates at speeds of 317 to 396 opm, on 117 volts D. C. (with resistor) or 60 cycle A. C. power.

SECTION 2

ADJUSTMENTS

1. GENERAL

a. This bulletin covers requirements and adjusting procedures for the maintenance of transmitter distributors, signal distortion test sets, and distributors. Adjustments are arranged in a sequence that would be followed if a complete readjustment of the unit were undertaken. In following such a procedure, parts or assemblies which are removed to facilitate adjustment should not be replaced until all other adjustments which would be facilitated by the removal of these parts are made. If one adjustment is changed, related adjustments should be checked. The adjustments up to and including "Main Shaft Clutch Torque Adjustment" Paragraph 2.a.(72) are common to all transmitter distributors but subsequent adjustments pertain to mechanisms which are not common to all units. These adjustments are preceded by a brief description to assist in the identification of the mechanism.

b. The spring tension values indicated in this bulletin are scale readings which should be obtained when Teletype scales are used as specified. Springs which do not meet the requirements specified and for which no adjusting procedure is given should be replaced with new springs. Ordering information may be obtained from the Teletype parts bulletin.

c. Before proceeding to adjust any part, read the applicable portion of the adjusting text carefully. After the adjustment is completed, be sure to tighten any screws or nuts which may have been loosened. If a part that is mounted on shims is to be dismantled, the number of shims used at each of its mounting screws should be noted so that the same shim pile-ups can be replaced when the part is remounted.

d. Do not rotate the governor, fan or distributor shaft (viewed from above) in a counter-clockwise direction, as this may mutilate the distributor brushes (Figure 4). A precaution which may be exercised to avoid mutilation of the brushes is to loosen the brush holder clamp screw (Figure 16 through 19) and turn the brush holder so as to lift the brushes from the commutator.

NOTE

For distributors only, in the following text when reference is made regarding the rotation of the main shaft, the stop lever should be disengaged from the stop lug on the stop cam and the governor or fan rotated in a clockwise direction.

CHANGE 1

References are made to the following notes in the applicable adjustments.

- (A) Remove the tape transmitter top plate.
- (B) Pertains only to transmitter distributor units equipped with all steel clutch.
- (C) Pertains only to units equipped with friction clutch.
- (D) Remove the contact bracket.
- (E) Remove the relay.
- (F) Applies to distributors.
- (G) Applies to transmitter distributor and signal distortion test set.
- (H) Use Dixons No. 677 graphite gear lubricant at places where grease is specified instead of the grease listed in the lubrication publication.
- (I) Applies only to two-channel start-stop transmitter distributors.
- (J) Applies to units that transmit BLANK combination when one channel only is idling.
- (K) Applies to units that transmit LETTERS combination when one channel only is idling.
- (L) Applies to transmitter distributor units equipped with a special start magnet assembly.
- (M) Does not apply to transmitter distributor units equipped with a special start magnet assembly.
- (N) Applies to signal distortion test set.

2. ADJUSTING PROCEDURE

NOTE

Before proceeding to adjust, remove the following parts: Distributor cover, tape exit guide, tape transmitter top plate, tape transmitter snap panel and distributor base plate. Also remove the left bracket from the transmitter assembly.

a. DISTRIBUTOR PROPER

- (1) "B" Transmitter Operating Lever (Figure 50) See Note (1) on Page 2-1

NOTE

This adjustment is made at the factory when the

unit is assembled and should require attention only when the shim pile-up has been disturbed or when new parts are being installed.

The "B" transmitter operating lever (front) should be in alignment with the "A" transmitter operation lever (rear). To adjust, add or remove shims between the operating lever bearing washer and the base casting.

(2) Main Shaft (Figure 20) - Rotate the main shaft until the operating-lever roller just starts to ride up the high part of the cam. Position the main shaft so that there is some clearance between the lower surface of the cam and the upper surface of operating lever when all the play of the operating lever is taken up in a direction to make the clearance a minimum. With the play in the operating lever taken up in a direction to make the clearance a maximum, this clearance should not exceed .040". To adjust, loosen the main-shaft bearing-cap screws and raise or lower the main shaft. Tighten the screws.

(3) Motor Position - There should be a minimum amount of backlash between the motor pinion and the main-shaft gear throughout a complete revolution of the main shaft (Figure 4). To adjust, loosen the motor mounting screws and position the motor. Tighten the screws.

(4) Magnet Core - See Note (F) or (L) and (B) on Page 2-1. The armature should strike both pole faces simultaneously and any air gap between the armature and the pole faces (when the armature is held against the pole faces) should not exceed .005". To adjust, loosen the start magnet core mounting screws and position the magnet core. Tighten the screws. See Figure 21 for location of parts.

NOTE

The side of the start magnet armature stamped "C" designates heavy chrome plating. This side should be next to the magnet core when unit is wired for direct current. When unit is wired for alternating current the "C" side should be away from the magnet core in order to reduce chatter and AC hum.

(5) Armature Plate - See Note (F) on Page 2-1 - The armature plate should cover fully the pole faces. To adjust, loosen the armature plate mounting screws and position the plate. Tighten the screws. See Figure 21 for location of parts.

(6) Stop Lever Pilot Screws - See Notes (C) and (F) on Page 2-1

(a) For type of stop cam shown in Figure 22A use following adjustment. See Fig-

ure 21 for location of parts:

With the reset extension resting on the high part of the stop cam lug, there should be from .010" to .020" clearance between the top surface of stop lever and lower surface of the stop cam at the closest point. Also, the stop lever should have some vertical play, not more than .004", without bind between the pilot screws. Gauge by feel. To adjust, loosen the stop lever pilot screw lock nuts and position the lever by means of the pilot screws. Tighten the lock nuts.

(b) For type of stop cam shown in Figure 22B use the following adjustment. See Figure 21 for location of parts:

With the stop cam lug against the end of the stop lever, the stop lever should fully engage the stop lug below its radius and the latching portion of the stop lever should engage the armature extension between its upper and lower edges. Also, the stop lever should have some vertical play, not more than .004", without bind between the pilot screws. Gauge by feel. To adjust, loosen the stop lever pilot screw lock nuts and position the lever by means of the pilot screws. Tighten the lock nuts.

(7) Stop Lever and (Latch Lever) Pilot Screws - See Notes (B), (F) and (L) on Page 2-1 With the clutch magnet de-energized and the end of the clutch shoe lever against the stop lever, the top of the stop lever should be flush with the top surface of the clutch shoe lever within .010".

To adjust, loosen the lock nuts and move the stop lever up or down as required by turning pilot screws.

Make certain that there is some, not more than .004", end play between the pilot screws (gauge by eye). Tighten lock nuts securely.

(8) Start Magnet Bracket (Figure 21) - See Notes (F) or (L) and (B) on Page 2-1 - When the armature is against the pole pieces and the armature extension resting on the bottom of the unlatch step of the stop lever, there should be from .002" to .006" clearance between the right edge of the unlatch step and the left edge of the armature extension at the closest point.

The right edge of the latch step of the stop lever should be parallel to the left edge of the armature extension in its latched position.

(a) (For distributors equipped with friction clutch) - With the armature in the latched position, the rear edge of the stop lever should be flush with or not more than .010" in front of

the rear edge of the stop cam lug.

(b) (For units equipped with all steel clutch) - When the cam is holding the stop lever at its greatest distance from the armature extension the latching step should be from .001" to .005" away from the end of the armature extension.

To adjust, loosen the start magnet bracket mounting screws and position the bracket. Tighten the screws.

(9) Armature Lever Spring Tension (Figure 23) - See Notes (F) or (L) and (B) on Page 2-1 - With the armature extension in its latched position (armature not attracted) and the stop lever held away from the end of the armature extension, it should require a pressure of 3 to 3-1/2 ozs. to start the armature moving when the push end of an 8 oz. scale is applied horizontally to the armature between the screws. To adjust, tighten or loosen the armature torsion spring by means of the bearing stud.

(10) Stop Lever Spring Tension

(a) See Notes (C) and (F) on Page 2-1 - With the armature in its latched position, hook a 32 oz. scale over the left end of the stop lever and pull horizontally at right angle to the stop lever. It should require from 11 to 16 ozs. to start the lever moving. See Figure 23 for location of parts.

NOTE

When measuring this tension the stop lever should not touch the stop lug.

(b) See Notes (B), (F) and (L) on Page 2-1 - Hold the armature against the magnet poles, making sure that the reset cam will not touch the camming leg of the stop lever, and hook an 8 oz. scale over the armature end of the stop lever. It should require from 3 to 6 ozs. to start the stop lever moving.

(c) See Notes (B) and (G) on Page 2-1 - With the clutch magnet de-energized and the stop lever not in contact with the clutch disk stop extension, it should require 1-1/2 to 2-1/4 ozs. to start the lever moving when an 8 oz. scale is hooked over the end of the stop lever. To adjust, loosen the bracket mounting screw so that it is friction tight and position the spring bracket in its mounting hole. Tighten the mounting screw. Check the latch lever spring tension.

(11) Latch Lever Spring Tension - See Note (B) on Page 2-1

(a) See Note (G) on Page 2-1 - With

the latch lever on the low portion of the clutch disk, hook an 8 oz. scale over the end of the latch lever and pull at a right angle to the lever. It should require 2 to 3 ozs. to start the lever moving. To adjust, loosen the bracket mounting screw so that it is friction tight and position the spring bracket in its mounting hole. Tighten the mounting screw. Check the stop lever spring tension.

(b) See Notes (F) and (L) on Page 2-1 - With the latching edge of the clutch disk away from the latch lever, hook an 8 oz. scale over the end of the latch lever and pull at a right angle to the lever, it should require 2 to 3 ozs. to start the lever moving.

(12) Latch Lever Stop - See Notes (B) and (G) on Page 2-1 - With the brushes rotated 180° from the stop position there should be a .020" to .030" gap between the outer circumference of the clutch disk and the tip of the latch lever. To adjust, loosen the latch lever adjusting screw and rotate it in or out to meet the requirement. Tighten the lock nut securely.

(13) Reset Cam - See Notes (B), (F) and (L) on Page 2-1

(a) See Notes (B) and (F) on Page 2-1 - The high point of the reset cam should be in line with the stop lug of the clutch disk and should ride in the center of camming leg of the stop lever. To adjust, loosen screws on cam and position. Tighten screw.

(b) See Notes (B) and (L) on Page 2-1 - The peak of the reset cam should just pass the end of the camming leg on the stop lever as the clutch shoe lever comes in contact with the stop lever. The reset cam should ride in the center of the camming leg on the stop lever. To adjust, loosen the clamp screw on the reset cam and position the cam. Tighten the clamp screw.

(14) Clutch Shoe Lever - See Note (B) on Page 2-1 (Figure 24) - With the clutch in its latched position (clutch disengaged) measure the gap between the clutch shoe lever and the clutch disk stop extension. With the clutch engaged and with the shaft rotated until the shoe lever and disk extension are easily accessible (and the stop lever not engaging the clutch shoe lever) measure the gap between the shoe lever and the stop extension. This gap should be from .055" to .085" greater than the one previously measured, with the clutch in its latch position.

To adjust, loosen the two clamp screws in the clutch disk and rotate the adjusting plate by engaging a wrench on the adjusting plate extension. Tighten the clamp screws.

After the above adjustment is made disengage the clutch and rotate the clutch drum. There should be no drag on the drum. If necessary, refine the above adjustment so that allowable gap is obtained.

(15) Clutch Shoe Spring Tension - See Note (B) on Page 2-1 (Figure 25)

NOTE

In order to check this tension it is necessary to remove the clutch from the main shaft. Therefore, it should not be checked unless there is good reason to believe that it does not meet its requirement.

With the clutch drum removed and an 8 oz. scale applied to the primary shoe at tangent to the friction surface it should require 3 to 5 ozs. to start primary shoe moving away from secondary shoe at point of contact.

(16) Clutch Shoe Lever Spring Tension - See Note (B) on Page 2-1

(a) See Note (F) (Figure 25) on Page 2-1 - With the clutch engaged and the clutch disk held to prevent it from turning, it should require 16 to 20 ozs. to move the shoe lever in contact with the stop lug when the pull end of a 32 oz. scale is applied, tangent to the clutch.

(b) See Note (G) (Figure 25) on Page 2-1 - With the clutch engaged and the clutch disk held to prevent it from turning, apply the pull end of a 32 oz. scale tangent to the clutch. It should require 16 to 20 ozs. to move the shoe lever in contact with the stop lug.

(17) Gear Guard - See Notes (B) and (F) on Page 2-1 - Make certain that the gear guard does not interfere with the gear.

(18) Operating Lever Spring Tension (100 WPM Operation) - See Notes (B) and (G) on Page 2-1 - With the operating lever roller on the low part of its cam, it should require 3-1/2 to 6-1/2 ozs. to stretch the spring to its position length (when pulling downward using an 8 oz. scale). Adjust by rotating the bracket after loosening the mounting screws. Tighten the mounting screws.

(19) Bail Spring Tension (100 WPM Operation) - See Notes (B) and (G) on Page 2-1 - When pulling upward with an 8 oz. scale, it should require 2 to 3 ozs. to stretch the spring to its position length.

(20) Tape Stop-Magnet Bracket - See Note (G) on Page 2-1

(a) Universal Magnet (Figure 26) - This adjustment applies to transmitter distributors equipped with a tape stop magnet having only one coil designed for operation on either A. C. or D. C.

This side of the tape stop magnet armature stamped "C" designates heavy chrome plating. This side should be next to the magnet core when the unit is wired for D. C. operation of the magnet. When the wiring is for A. C. operation, the "C" side should be away from the magnet core in order to reduce chatter and A. C. hum.

NOTE

For D. C. operation; assemble with the notch near top of armature (toward the coil). For A. C. operation; assemble with notch near bottom of armature (away from coil).

1. The air gap between both the upper and lower pole faces of the magnet yoke and the face of the armature should be approximately equal and from .010" to .020" when the magnet armature is resting against the magnet core. To adjust for equal air gap, increase or decrease the number of shims on the magnet yoke mounting screws between the magnet yoke and the magnet bracket. To adjust for the .010" to .020" gap, increase or decrease the number of shims between the magnet core and the yoke.

2. When the armature is resting against the magnet core and the stop-cam lug is opposite the end of the stop arm, there should be .004" to .012" clearance (a) between the stop-arm lug and the end of the stop arm for units equipped with friction clutch (b) between the stop lever and the clutch shoe lever or the clutch disk stop extension, whichever is closest, at the point of minimum clearance for units equipped with an all steel clutch. Also, both upper and lower pole faces of the magnet yoke should be parallel to the face of the armature, and the pole faces should not extend beyond either side of the armature. To adjust, position the magnet bracket by means of its mounting screws.

NOTE

If the magnet hums when energized with A. C., turn the bracket in a counter-clockwise direction slightly to decrease the clearance between the armature and the part of the center pole encircled by the copper slug. Under this condition the maximum gap should be increased from .020" to .025".

(b) D. C. Magnet (Figure 27)

NOTE

When making this adjustment, see that the magnet cores do not extend beyond the sides of the

armature. Also, when the armature is resting on the magnet core, there should not be more than .010" space between the armature and the other magnet core.

This adjustment applies to transmitter distributors equipped with a tape stop magnet having two coils designed for D. C. operation only.

When the magnet armature is held against the magnet cores and the stop-cam lug is opposite the end of the stop arm, there should be .004" to .012" clearance between the stop-cam lug and the end of the stop arm. To adjust, loosen the bracket mounting screws and position the bracket. Tighten the screws.

(21) Stop-Arm Pilot Screws (Figure 28) See Note (C) on Page 2-1 - With the stop cam lug against the end of the stop arm, the stop arm should project above the upper edge and below the lower edge of the stop cam lug when engaging the lug, and have some vertical play, not more than .004", without bind between the pilot screws. Gauge by eye and feel. To adjust, loosen the stop arm pilot screw lock nuts and position the arm by means of the pilot screws. Tighten the lock nuts.

(22) Stop-Arm Spring Tension (Figure 29) - See Notes (C) and (G) on Page 2-1 - With the stop arm resting on the low part of the stop cam, hook an 8 oz. scale over the end of the stop arm and pull at a right angle to the stop arm. It should require a pull of 5 to 7 ozs. to start the stop arm moving away from the stop cam on units having synchronous or D. C. motors. On units having A. C. governed motors (that employ the 86960 contact assembly, (Figure 15) the spring tension should be 2-3/4 to 3-3/4 ozs. The contact spring should be held away from the stop arm when this tension is measured.

(23) Stop Lever Pilot Screws (This adjustment should be made in conjunction with the Armature Backstop Adjustment) See Notes (B), (G), and (M) on Page 2-1 - With the clutch magnet de-energized, the top surface of the latch lever should be flush to within .015" above the top surface of the disk, when the play in the latch lever is taken in an upward direction. To adjust, loosen the pilot screw lock nuts and position the latch lever by means of the pilot screws. Tighten the lock nuts. Check to see that the stop lever is free on its bearings, but it should not have perceptible play.

NOTE

The extension of the armature backstop bracket should be against the mainshaft casting when the lock nuts are tightened.

(24) Armature Backstop (This adjustment should be made in conjunction with the Stop Lever Pilot Screws Adjustment) - See Notes (B), (G) and (M) on Page 2-1 - With the clutch magnet de-energized and clutch disengaged, the inner surface of the stop arm and the inner surface of the shoe lever should be approximately flush. To adjust, loosen backstop screw lock nut and position the backstop screw. Tighten the lock nut.

NOTE

Refer to NOTE listed under Stop Lever Pilot Screws Adjustment.

THESE REQUIREMENTS APPLY TO TRANSMITTER DISTRIBUTOR WHICH IS EQUIPPED WITH A 925 OHM 115 V. D. C. STOP MAGNET AND A STOP-MAGNET CONTACT LOCATED DIRECTLY ABOVE THE STOP MAGNET. THE STOP-MAGNET ARMATURE ACTUATES THE CONTACT AND IS OPERABLE ON D. C. ONLY. THE CONTACT CONNECTS TO AN EXTERNAL CIRCUIT.

THE STANDARD 5 TO 7 OZS. STOP ARM SPRING TENSION REQUIREMENT APPLIES REGARDLESS OF THE TYPE OF MOTOR USED. HOLD OFF THE CONTACT SPRING WHEN MEASURING.

THE FOLLOWING STOP MAGNET CONTACT REQUIREMENT APPLIES ONLY TO TRANSMITTER DISTRIBUTORS EQUIPPED WITH A STOP-MAGNET CONTACT WHICH IS POSITIONED DIRECTLY ABOVE THE STOP MAGNET. THE STOP MAGNET ARMATURE ACTUATES THE CONTACT.

(25) Stop Magnet Contact - See Figure 30.

NOTE

With the armature held against the magnet core, the stop magnet contact should meet the first three of the following requirements. (If there is no clearance between the armature and the insulator on the long contact spring, move the upper contact bracket forward to provide clearance.)

(a) The contact springs and stiffener should be in line and the whole pile-up should be vertical to the base casting. Adjust by means of the pile-up mounting screws.

(b) The short contact spring should bear against its stiffener with perceptible pressure. To adjust, bend the short contact spring.

(c) With an 8 oz. scale hooked

over the long contact spring at the contact point and pulled at a right angle to the spring, it should require 1 to 1-1/2 ozs. to break the contact. To adjust, bend the long contact spring.

(d) With the stop arm on the low part of the stop cam there should be a gap of .015" to .020" between the contact points. When the armature is held against the magnet core there should be some clearance between the insulator on the long contact spring and the armature. To adjust, position the upper contact bracket. Tighten the mounting screws. Make the Rubout Deleting Mechanism Adjustments (78) to (85) if unit is so equipped.

THE FOLLOWING ADJUSTMENTS, UP TO AND INCLUDING "FEED-LEVER SPRING TENSION ADJUSTMENT", ARE INTERRELATED AND MUST BE MADE IN THE ORDER GIVEN. THEREFORE, IF IT BECOMES NECESSARY TO CHANGE ANY ADJUSTMENT, ALL SUBSEQUENT ADJUSTMENTS IN THIS GROUP SHOULD BE CHECKED.

(26) Tape Feed-Pawl Spring Tension (Figure 31) - See Note (A) on Page 2-1 - Rotate the motor shaft until the feed pawl is in its uppermost position. Apply the push end of an 8 oz. scale to the feeding tip of the tape feed pawl and push horizontally toward the left. It should require 1 to 2 ozs. to hold the pawl in a vertical position. To adjust, loosen the feed-pawl mounting screw and position the spring. Tighten the mounting screw.

(27) Detent-Lever Spring Tension (Figure 32) - See Note (A) on Page 2-1 - Hold the transmitter top plate upside down and in a horizontal plane. Make sure that the detent roller is resting in the hollow between two teeth on the feedwheel ratchet. Hook a 32 oz. scale over the end of the detent lever and pull horizontally against the tension of the spring. It should require 15 to 18 ozs. to start the detent lever moving when the detent lever is provided with a rounded surface opposite the round boss for the spring, as shown on Figure 16. When a new style detent lever having a protruding rib to facilitate hooking of the scale is provided, the spring tension should measure 12 to 15 ozs.

(28) Feed-Wheel Shaft Bearings (Figure 32 for location of parts) - See Note (A) on Page 2-1 - The feed-wheel shaft should be free in its bearings and should have some end play, not over .002". To adjust, loosen the feed-wheel shaft bearing mounting screws and position the bearings. Tighten the screws.

(29) Tape Retaining-Lid Latch Wearing-Strip Shims (Figure 33) - With a .003" thickness gauge placed between the retaining lid and the

front guide rail on the tape-guide plate the latch should not close freely. With the gauge removed and the retaining lid held against the front guide rail on the tape-guide plate, the latch should operate freely under its own spring tension. To adjust, increase or decrease the number of shims installed between the latch wearing strip and top plate.

(30) Tape Space (Figure 34) - On units designed to use chadless tape, the clearance between the tape guide and the retaining lid plate should be .011" to .014" throughout the area of the retaining lid plate when the retaining lid is latched closed and the play is taken up in a direction to make this clearance a minimum. On transmitter distributors designed to handle only the regular tape, this clearance should be .006" to .008". To adjust, increase or decrease the number of shims installed between the retaining lid and the retaining lid plate.

When spliced chadless tape is used the clearance requirement should read .014" to .016". Under this condition a check should be made for closure of the spacing contacts with blank tape in the transmitter.

(31) Tape Guide (Figure 35)

(a) When a piece of perforated tape is engaged with the pins of the feed wheel, there should be equal clearance between the edges of the tape and the tape guide. To adjust, loosen the tape-guide mounting screws and position the guide. Tighten the screws.

(b) For units equipped with adjustable tape guide, with the tape held in the tape guide so that there is equal clearance between the edges of the tape and the tape guide, adjust the eccentric posts so that there is just perceptible clearance between the posts and the edges of the tape. Tighten eccentric clamp screws.

Make the Single Step Tape Feed Suppression Mechanism adjustments in paragraphs (94) to (103) for distributor units so equipped.

REPLACE THE TAPE TRANSMITTER TOP PLATE. WHEN DOING THIS, HOLD THE FEED PAWL SO THAT IT ENGAGES THE FEED-WHEEL RATCHET. IF THE UNIT IS EQUIPPED WITH THE END-OF-TAPE STOP-CONTACT MECHANISM, HOLD THE CONTACT OPERATING PIN TO PREVENT IT FROM FALLING OUT OF ITS GUIDE.

NOTE

There should be at least .020" clearance between the side of the feed pawl spring and the contact-

lever guide. For transmitter distributors, there should also be at least .025" clearance between the feed-pawl spring and the feed-wheel ratchet when the feed pawl is in its uppermost position. If these clearances do not exist, modify the "Tape Feed-Pawl Spring Tension Adjustment" within its specified limits to obtain the required clearance.

(32) Detent Bracket (Figure 35) - Obtain a piece of tape with a series of LETTERS perforations. Either regular tape or chadless tape may be used. Check the tape to determine whether or not the spacing of the perforations meets the requirement of ten holes to the inch. (If chadless tape is used, fold the lids of one set of five perforations backward so that the lids do not obstruct the holes.) Engage the feed perforations with the feed wheel so that the unobstructed perforations are directly over the tape pins. (1) For transmitter distributors disengage the stop arm from the stop-cam. (2) For distributors, disengage the stop lever from the stop lug on the stop cam. Then rotate the governor or fan in a clockwise direction (when the unit is viewed from the front) until the tape pins are flush with the bottom of the tape. Check to see that the detent roller is resting in an indent between two teeth of the feed-wheel ratchet. When the play of the tape on the feed wheel is taken up toward the left, the tape pin farthest to the right should just clear the right edge of its associated code hole. To adjust, loosen the detent-bracket mounting screws and position the bracket. Tighten the screws.

(33) Tape Retaining-Lid Plate (Figures 34 and 36)

(a) The three types of plates in use on tape-retaining lids are shown in Figure 36. Either regular or chadless perforated tape may be used with the types shown at A or B, but only regular perforated tape can be used with the type shown at C. Types A and B are interchangeable on units designed to use chadless tape. Type C can be used only on units designed to use regular perforated tape. Type A was designed to accommodate spliced chadless tape.

(b) Type A and B should be positioned so that the edges of the plate are parallel to the tape guide and when the main shaft is rotated the retaining lid plate should not interfere with the lids of chadless tape when the lids are raised by the tape pins. In checking the adjustment of type B, take up the play of the tape on the feed wheel pins toward the right with the feed-wheel detent resting in an indent between two teeth on the ratchet.

(c) If regular tape is to be used exclusively, type A, B, or C should be adjusted

so that the edges of the plate are parallel to the guide and so that the openings in the plate are centrally located with respect to the pins when the pins are in their uppermost position. To adjust, loosen the retaining-lid-plate mounting screws and position the plate. Tighten the screws.

(34) Retaining-Lid Latch Spring Tension (Figure 33 for location of parts) - With the slope on the latch resting against the top plate (not latched), hook an 8 oz. scale over the upper end of the latch and pull at right angle to the formed upper end of the latch. It should require 1-1/2 to 7 ozs. to start the latch moving on its pivot.

(35) Feed-Lever Adjusting Screw (Figure 37) - When the contact-lever bail is slowly operated by hand, the feed pawl should engage the first tooth above the horizontal center of the feed-wheel ratchet at the instant the tape pins are flush with the upper surface of the tape guide. To adjust, loosen the feed-lever adjusting-screw lock nut. Turn the adjusting screw clockwise if the tape pins are below the top surface of the tape guide when the feed wheel starts to move or counterclockwise if the tape pins extend above the top surface of the tape guide when the feed wheel just starts to move.

(36) Operating-Lever Adjusting Screw (Figure 38) - When the operating-lever roller is on the highest part of its cam and the detent roller rests between two teeth on the feed-wheel ratchet, there should be some clearance, not over .010", between the face of a tooth on the ratchet wheel and the face of the feed pawl. To adjust, loosen the operating-lever adjusting screw lock nut and position the adjusting screw. Tighten the nut and recheck the clearance.

NOTE

For two-channel transmitter distributors, in meeting these requirements, the adjusting screws of both transmitters should be set approximately the same in their operating levers. If this is not the case, loosen the operating lever link clamp screws and lengthen or shorten the link so that the "B" transmitter adjusting screw will be set approximately the same as the "A" transmitter adjusting screw when the "B" transmitter adjusting screw adjustment is remade. Tighten the operating lever link clamp screws and refine the "B" transmitter adjusting screw adjustment by means of its adjusting screw. Tighten the nut and recheck the adjustment.

(37) Contact Tongues Alignment (Figure 39)

NOTE

The following adjustment is made during the in-

itial assembly of the unit and should require attention only if the parts have been damaged or dismantled. To check, back off contact screws.

The contact tongues should be straight and parallel (both crosswise and lengthwise) to the upper contact screw bridge. The variation in alignment should not exceed .030". To adjust, bend the contact tongues.

(38) Feed-Lever Stop (Figure 40)

(a) Transmitter distributors designed to handle chadless tape should be equipped with an operating cam identified by letter X or XX stamped in it (Figure 20). When this cam is used, a stop is provided for the feed lever which should be adjusted as follows:

1. With the operating-lever roller on the low part of the operating cam and the detent roller resting in the notch between two teeth of the feed wheel ratchet, there should be .050" to .070" clearance between the face of feed pawl and the face of the first tooth above the horizontal center line of the feed-wheel ratchet. The feed lever should be in contact with the blocking surface of the feed lever stop. To adjust, loosen the feed-lever stop mounting screw and position the stop. Tighten the mounting screw.

2. Rotate the motor manually until the adjusting lever (Figure 37) just contacts the lobe on the feed lever. With the contact-lever bail in this position there should be at least .002" clearance between the bail and each contact-lever lobe (Figure 41). If necessary, refine the feed-lever stop adjustment.

NOTE

With the operating lever on the low part of the operating cam, there should be at least .010" clearance between the radius of the feed pawl or the feed-pawl spring and the feed-wheel ratchet. If this clearance does not exist, refine the feed-lever stop adjustment.

(39) Tape Transmitter Contacts - The contacts require very little attention because no current is flowing through them at the moment the contact tongues leave the contact screws. When periodic inspection is made, the contacts should be cleaned with a contact burnisher or a piece of fine carborundum cloth. Particles of grit should be carefully wiped away after this operation.

(40) Lower Contact Screw (Figure 41)

(a) For Units Designed to Use Chadless Tape - Rotate the main shaft until the operating-lever roller is resting on the low part

of its cam and place a straightedge across the top of the tape guide directly over the tape pins. There should be a clearance of .020" to .025" between the bottom of the straightedge and the top of each tape pin. To adjust, loosen the set screws of the upper and lower contact screws and back off the upper contact screws. Then adjust the lower contact screws to meet the requirement. Tighten the lower contact-screw set screws.

NOTE

There should also be a clearance of at least .002" between the contact-lever bail and the lobe of each contact lever. If this clearance does not exist, refine the lower contact screw adjustments within the specified limits to obtain the desired clearance.

(b) For Units Designed to Use Regular Tape Exclusively - In order to check this adjustment it will be necessary to remake it. With the contact screw set screws loosened and the upper and lower contact screws backed off, rotate the main shaft until the operating-lever roller is on the low part of its cam. Advance the lower contact screws until their contact points just touch the points on the contact tongues. To determine this point, use a test lamp. Then advance the lower contact screws an additional full turn and tighten their set screws.

(41) Upper Contact Screw (Figure 41) With the operating-lever roller on the low part of its cam, there should be a gap of .006" to .010" between the contact point of each upper contact screw and its associated contact tongue. To adjust, loosen the upper contact-screw set screws and adjust the upper contact screws. Tighten the set screws.

(42) Contact-Lever Spring Tension (Figure 41) - With the operating-lever roller on the low part of its cam, hook an 8 oz. scale under the horizontal portion of a contact lever (the scale rod just clearing the contact tongue pivotal mounting) and pull vertically upward. The pull required to separate the contacts should be 3 to 4 ozs. on units designed for use with regular tape exclusively, and 6 to 7 ozs. on units designed to use chadless tape. Use a test lamp to determine when the contacts break. Measure all contact-lever springs in the same manner. To adjust, loosen the contact-lever spring-anchor terminal screws and position the anchors. Tighten the terminal screws.

(43) Contact Lever Movement (Figure 41) - The contact levers should move freely to permit the lower contacts to close.

To gauge, pull each contact lever

with the scale, as shown in Figure 41, until the lower contacts open. Gradually reduce the pull until the contacts close. The scale reading should not drop more than $3/4$ ozs.

To adjust, remove the contact lever; clean the lever and the guide slot. Stone down any burrs on the lever and in the guide slot. If the bind has not been removed, replace the contact lever with a new one. Check the alignment of the contact lever spring. If it is sufficiently out of line with the plane of the contact lever to cause a side pull, so that the lever binds in its slot, resolder the spring taking care not to damage the spring or the terminal block by too much heat.

(44) Feed-Lever Spring Tension (Figure 37) - With the operating-lever roller on the low part of its cam, hook a 32 oz. scale over the end of the feed lever (just below the spring hole) and pull upward in line with the spring. It should require 17 to 19 ozs. to start the feed lever moving. To adjust, loosen the terminal screw and position the spring anchor. Tighten the terminal screw.

(45) Tight - Tape - Stop or Auto - Stop Mechanism (Figures 42, 43, and 44) - See Note (G) on Page 2-1

(a) These two names are used interchangeably to refer to the same mechanism. There are four types of this mechanism in use, however.

1. Adjust the type shown in Figure 42 to meet the following requirements;

a. When the contacts are held closed by the contact operating post, the bottom of the tight-tape stop lever should be horizontal and the tight-tape stop shaft should protrude approximately $1/16$ " beyond the clamp (Figure 42A). Make the adjustments simultaneously by positioning the clamp.

NOTE

For installations where the transmitter distributor operates at a faster speed than the unit preparing the tape, adjust as follows:

b. When the contacts are held closed by the contact operating post the bottom of the tight-tape stop lever should be approximately one inch below the normal horizontal position and the tight-tape stop shaft should protrude approximately $1/16$ " beyond the clamp (Figure 42A). Make the adjustments simultaneously by positioning the clamp.

c. When the contact op-

erating post is held away from the left contact-spring insulator, there should be .015" to .025" clearance between the contact points and .015" to .025" clearance between the right contact-spring insulator and the tight-tape stop mechanism bracket. To adjust, bend the contact springs (Figure 42B).

2. Adjust the type shown in Figure 43 to meet the following requirements:

a. When the contact spring post is held away from the left contact-spring insulator, there should be .015" to .025" clearance between the contact points and .015" to .025" clearance between the right contact-spring insulator and the contact-spring bracket. To adjust, bend the contact springs.

b. When the auto-stop lever is held so that the contact spring post is in a horizontal position, the auto-stop lever spring should also be in a horizontal position. To adjust, loosen the auto-stop-lever shaft-collar set screw and position the collar. Tighten the set screw.

3. Adjust the type shown in Figure 44 to meet the following requirements:

a. With the contact bracket in contact with its right-hand eccentric stop, hook a 32 oz. scale over the end of the contact-bracket arm and pull at right angle to the arm. It should require 3 to 10 ozs. to start the bracket moving.

b. When the operating arm is held away from the left-hand contact-spring insulator, there should be .015" to .025" clearance between the contact points and .025" clearance between the right-hand contact-spring insulator and the extension on the contact bracket. Adjust by bending the contact springs.

c. When the contact bracket is up against the left-hand eccentric stop, the portion of the operating-arm rod which is engaged by the tape should be $3/4$ " to $1-1/4$ " below the upper surface of the tape guide on the transmitter top plate (See Figure 42A). To adjust, loosen the left-hand eccentric-stop mounting screw and position the eccentric stop. Tighten the mounting screw.

d. The right-hand eccentric stop should be adjusted to suit the requirements of the user. The greater the amount of slack tape required between the perforator and the transmitter distributor, the higher the eccentric should be positioned, and vice versa. To adjust, loosen the right-hand eccentric stop mounting screw and position the eccentric stop. Tighten the mounting screw.

4. Adjust the type shown in Figure 45 to meet the following requirements:

a. The loop of the tape-stop rod should be positioned to the right and downward (when viewing the machine from the transmitter end) so that it will make angle of approximately 45 degrees with the horizontal plane (Figure 45A). Adjust by means of the set screw and lock nut in the tape-rod clamp.

b. When the contacts are held closed by the contact operating post, the distance between the top surface of the tape-transmitter top plate and the middle of the bend in the tape-stop rod should be 1-3/4" plus or minus 1/16" (Figure 45B). The tight-tape stop shaft should protrude approximately 1/16" beyond the tape-rod clamp.

c. For adjustments of clearances between contact points and between the right contact-spring insulator and the tight-tape-stop mechanism bracket, refer to Paragraph 2. a. (45)(a)1. c.

(46) Distributor Brushes

(a) Transmitter distributors are provided with either carbon brushes or braided copper wire brushes; distributors are provided with carbon brushes. The contact pressure of carbon brushes should be readjusted occasionally to compensate for brush wear. This is done by rotating the brush holder and resurfacing the brushes. When the contact pressure of braided brushes becomes inadequate due to wear, the brushes should be trimmed square and relocated. When trimming brushes, a piece of paper should be inserted between the brushes and the commutator disk.

(b) There are two styles of brush arms. The latest design clears the commutator by about 1/16" as shown in Figures 16 and 17. The older design clears the commutator by about 1/4" as shown in Figure 18. Braided brushes are used exclusively with the high brush arm and brush stiffeners are employed. Either braided or carbon brushes may be used with the low brush arm and stiffeners are not required. The adjusting procedure and requirements for each style of brush and brush arm are as follows:

1. Carbon Brush (Figures 16 and 88).

NOTE

For signal distortion test set, if either of the brushes which ride on the two segmented rings is readjusted or replaced, the Signal Distortion Calibration adjustment should be remade.

a. Transmitter distributors and signal distortion test set - With the main shaft in the stop position (the lug on the stop cam against the blocking edge of the stop arm), the brushes (three innermost for signal distortion test set) should make contact with their associated segments at a point in line with the line impressed in the disk. For signal distortion test set, the outer brush should make contact with its segment in line with the three inner brushes. The brushes should also remain within the edges of the rings throughout a complete revolution of the main shaft. To meet the first requirement, loosen the brush-spring clamp screw and position the brushes. Tighten the clamp screw so that the brush springs are friction tight. To meet the second requirement, loosen the brush holder clamp screw and position the brush holder, or utilize the play of the brush springs in their slots, to position the springs sideways. Tighten both clamp screws.

b. Distributors - With the main shaft in its stop position, loosen the three screws used for mounting the outer disk and move the adjustable disk so that the leading edge of the No. 5 segment is in line with the point 60 on the orientation scale. Position the entire brush arm holder assembly so that the carbon brushes will not overlap their respective commutator rings during an entire revolution of the main shaft.

NOTE

The second requirement may be further refined by positioning each brush in its retainer slot of the brush arm.

The edge of the brushes should line up with the inscribed line on the adjustable disk. The brushes should be centrally located with respect to their associated segments. To adjust, loosen the brush spring clamp screw and position the brushes. Tighten the clamp screw. Recheck second requirement.

c. Two-channel transmitter distributors (Figure 19) - Loosen the brush holder clamp screw and rotate the brush holder so that the top surface is horizontal. Rotate the main shaft in a clockwise direction until the outer end of the brush holder is 3/8" (plus or minus 1/64") past the stop position line in the insulating disk. With the shaft held in this position, rotate the brush holder so that the brushes touch the commutator rings and clamp the brush holder friction tight. Adjust the brushes and their stiffeners by means of the brush holder clamp plate so that the brushes are centered on the stop position line and the end of each stiffener should not touch the carbon element of the

brush but should clear it by approximately 1/16".

d. Brush Spring Tension

(1.) Hook an 8 oz. scale under the end of each distributor brush spring and pull upward at a right angle to the end of the brush spring. It should require 2-1/2 to 3-1/2 ozs. (for units not equipped with brush stiffeners), 3 to 4 ozs. (for units equipped with brush stiffeners), to lift the brush from its segment. To determine this point, use a test lamp.

(2.) Adjust the spring tension in the following manner: Loosen the brush-holder clamp screw so that the brush holder is friction tight. Rotate the brush holder counter-clockwise until the brushes are lifted from their segments and adjust the brush springs by bending them slightly, if necessary, so that the contact surface of the brushes are equidistant from and parallel to the segments. Then rotate the brush holder clockwise until the brushes rest against the segments with a pressure of about 3-1/2 ozs. (for units not equipped with brush stiffeners), 4 ozs. for units equipped with brush stiffeners and tighten the clamp screw. Place a piece of fine sandpaper (approximately 1" wide) face up on the distributor disk and draw the brushes across it two or three times or until the bottoms of the brushes are parallel to the surface of the segments. Recheck the spring tension and readjust if it does not meet the requirements.

(3.) If it is found necessary to readjust the brush holder to obtain the proper spring tension, the brushes should be resurfaced in accordance with the foregoing instructions.

2. Braided Brush - Low Brush Arm (Figure 17)

a. Loosen the brush-holder clamp screw and rotate the brush holder so that the ends of the brushes just touch the commutator segment and ring. With the main shaft in its stop position (the lug on the stop cam against the stop arm), the brushes should be straight and the ends should coincide with the line impressed in the commutator disk. To adjust, loosen the brush clamp screw and position the brushes. Tighten the screw.

b. With the brushes straight and just touching the commutator rings, there should be .015" to .020" clearance between the brush holder stop post and the eccentric stop. To adjust, loosen the brush-holder clamp screw so that the brush holder is friction tight. Then loosen the eccentric-stop mounting screw and position the brush holder and eccentric stop.

Tighten the eccentric-stop mounting screw. Rotate the brush holder so that its stop post is in contact with the eccentric stop and tighten the brush-holder clamp screw.

3. Braided Brush - High Brush Arm (Figure 18)

a. Loosen the brush-holder clamp screw and rotate the brush holder so that the ends of the brushes just touch the commutator segment and ring. With the main shaft in its stop position (the lug on the stop cam against the stop arm), the brushes and stiffeners should be straight and in contact with each other throughout their length, the ends of the brushes should coincide with the line impressed in the commutator disk, and the ends of the stiffeners should be 3/32" to 1/8" from the trimmed ends of the brushes. To adjust, loosen the brush clamp screw and position the brushes and stiffeners. Tighten the brush clamp screw and tighten the brush-holder clamp screw so that the brush holder is friction tight.

b. With the brushes just touching the commutator rings, there should be .020" to .025" clearance between the brush-holder stop post and the eccentric stop. To adjust, loosen the brush-holder clamp screw so that the brush holder is friction tight. Then loosen the eccentric-stop mounting screw and position the eccentric stop and brush holder. Tighten the eccentric-stop mounting screw. Rotate the brush holder so that its stop post is in contact with the eccentric stop and tighten the brush-holder clamp screw.

ADJUSTMENTS FOR THE BREAK-LOCK MECHANISM - See Note (G) on Page 2-1

(47) Mounting Plate (Figure 46) - With the distributor brush arm in the stop position, the end of the shunt contact lever should rest on its cam 1/32" (plus or minus 1/64") from the edge of its notch in the cam. To adjust, unhook the contact pawl spring from its spring post and position the mounting plate by means of its elongated holes. Rehook the spring.

(48) Magnet Bracket (Figure 46)

(a) With the armature held against core of the magnet, both faces of the core should be flush against the armature.

(b) With the armature lever held against the high part of its cam by its spring, there should be .002" to .003" clearance between the magnet core faces and the armature.

(c) To adjust, for the first requirement, bend the magnet bracket at a point

near the mounting plate. To adjust for the second requirement, position the magnet bracket by means of its enlarged mounting holes.

(49) Magnet Core (Figure 46) - With the armature in its attracted position, the magnet core should be approximately equidistant from the ends and sides of the armature. To adjust, position the magnet core by means of the enlarged holes in the magnet bracket. Recheck the MAGNET BRACKET ADJUSTMENT.

(50) Shunt Contact (Figure 47) - Remove the shunt contact bracket from the mounting plate. Hook an 8 oz. scale to the insulator on the long contact spring and pull at right angles to the insulator. It should require 1 to 2 ozs. to separate the contact points. To adjust, bend the long contact spring. Replace the bracket.

(51) Shunt Contact Bracket (Figure 46)

(a) With the shunt contact lever on the high part of its cam, there should be some clearance, not over .003", between the post on the shunt contact lever and the insulator on the long shunt contact spring.

(b) Rotate the motor shaft by hand until the shunt contact lever just falls into the indent in its cam. With the contact pawl kept in the unlatched position, the shunt contact lever post should exert pressure on the insulator of the long contact spring and provide a contact gap of at least .010". To adjust for both requirements, position the shunt contact bracket by means of the enlarged mounting holes.

(52) Push Rod Lock (Figure 48)

(a) With the stop pin of the push rod resting against its lock (in the unlocked position) the end of the push rod should rest in the bearing in the mounting plate and should not extend more than 1/32" beyond it.

(b) With the push rod in the disabled position, the contact lever should be disengaged from its cam. To adjust for both requirements position the push rod lock by means of its elongated mounting holes.

(53) Break Contact

(a) With the contact pawl in the unlatched position and the push rod in its disabled position, initially tension the long BREAK contact spring. Under this condition, there should be some clearance, not over .003" between the insulator on the long BREAK contact spring and the stud on the contact pawl. See Figure 46. To adjust, bend the short BREAK contact spring.

(b) With the contact pawl in the un-

latched position, hold the insulator on the long MAKE contact spring away from the insulator on the long BREAK contact spring. Under this condition hook an 8 oz. scale to the insulator on the long BREAK contact spring and pull at right angles to the spring. It should require 1 to 2 ozs. to separate the contacts and both contacts should break approximately simultaneously. See Figure 49. To adjust, bend the long BREAK contact spring. Recheck requirement a.

(54) Make Contact

(a) With the contact pawl in the unlatched position, the insulator on the long MAKE contact spring should just make contact with the insulator on the long BREAK contact spring. See Figure 46. To adjust, bend the long MAKE contact spring.

(b) With the contact pawl in the unlatched position, initially tension the short MAKE contact spring against its stiffener. Under this condition the MAKE contact gap should be from .010" to .015". To adjust, bend the stiffener.

NOTE

It will be necessary to remove the break-lock cam while checking the following requirement:

(c) With the contact pawl in the latched position, and the armature held against the magnet core, hook an 8 oz. scale to each prong of the bifurcated short MAKE contact spring, at a point next to its contact, and pull at right angles to the spring. It should require a pull of 1 to 2 ozs. to break contact on each prong of the bifurcated spring. To adjust, bend the short MAKE contact spring. Recheck requirement b. Replace the cam.

(55) Contact Pawl Spring Tension - Unhook the contact pawl spring from the contact pawl, and its spring post and attach the loop of one end to some convenient object. With an 8 oz. scale hooked to the free loop it should require a pull of 3-1/2 to 4 ozs. to extend the spring to a length of 1-1/32", when pulling horizontally. See Figure 46. Replace the spring.

(56) Shunt Contact Lever Spring Tension - With the shunt contact lever on the high part of its cam, hook an 8 oz. scale to the lever (just under the point of engagement of the shunt contact lever with the cam) and pull in a direction parallel to the side of the base casting. See Figure 46. It should require 6 to 8 ozs. to start the shunt contact lever moving away from the cam.

(57) Armature Lever Spring Tension - Unhook the armature lever spring from the arm-

ature lever and hook a 2 lb. scale through the free loop. It should require a pull of 11 to 13 ozs. to extend the spring to a length of 1-1/2", when pulling horizontally. See Figure 46. Rehook the spring.

(58) Armature Lever Spring

(a) The armature lever spring tension is set at the factory for use on .060 ampere, signal line circuits, with the break-lock mechanism operating so as to stop transmission if the signal line current is reduced to .020 ampere or less.

(b) The spring setting and operation of the break-lock mechanism must be checked by operating the transmitter distributor with its signal circuit in series with a local test (or comparable) circuit consisting of a source of 115 volts D.C., a milliammeter, a variable resistor of approximately 6000 ohms and a jack, all in series. Adjust the resistor so that .020 ampere flows through the test circuit. Start the transmitter distributor in operation. If the transmitter distributor is equipped with an end-of-tape stop feature, it will be necessary to short-circuit the associated contact or to run tape through the transmitter. The break-lock mechanism should operate and stop transmission within two revolutions of the distributor after each restarting with the push rod. When properly adjusted, the break-lock mechanism should stop transmission when the signal line current is .020 ampere or less, but should not stop transmission at any time when the steady current is .025 to .030 ampere. To adjust, loosen the two nuts which lock the armature lever spring stud and position the stud. See Figure 46.

If it is desired to use the break-lock mechanism on .020 ampere line circuits, the armature lever spring tension should be adjusted to such a value as to cause the mechanism to operate and stop transmission if the signal line current is reduced to some value below .020 amperes. A procedure similar to that outlined in requirement (b) above should be followed.

END OF BREAK-LOCK MECHANISM ADJUSTMENTS

(59) Operating Cam

(a) Transmitter Distributors and Signal Distortion Test Set - See Notes (B) and (N) on Page 2-1

1. The operating cam should be positioned so that the No. 5 Transmitter Contact Tongue leaves the lower (MARKING) contact screw when the distributor brush is on the STOP

segment. The trailing edge of the carbon brush should be on an oblique angle to the leading edge of the STOP segment. The trailing inside corner of the carbon brush should be 1/32" to 1/16" from the leading edge of the STOP segment, on the adjustable disk (see Note (N)). The trailing outside corner of the carbon brush should be up to 1/32" further from the leading edge of the STOP segment, on the adjustable disk (see Note (N)). To adjust, loosen the operating cam mounting screws and position the cam. Tighten the mounting screws. To adjust carbon brushes, loosen holder clamp screw, utilize the play of the springs in their slots, position as needed and tighten clamp screw. Recheck the Carbon Brush Spring Tension Adjustment, paragraph (46)(b)1.d.

2. Transmitter Distributor

(See Note (C) on Page 2-1 - The operating cam should be positioned so that the No. 5 transmitter contact tongue leaves the lower (marking) contact screw when the distributor brush is on the "stop" segment and the trailing edge of the brush is 1/32" to 1/16" from the leading edge of the "stop" segment. To adjust, loosen the operating cam mounting screws and position the cam. Tighten the mounting screws.

3. Signal Distortion Test Set

(See Note (C) on Page 2-1 - Turn the motor fly-wheel until the distributor brush has passed onto the "stop" segment 1/32" to 1/16". With the brush in this position, the No. 5 transmitter contact tongue should just leave the lower (marking) contact screw. To determine this point, use a test lamp. To adjust, loosen the transmitter operating cam mounting screws and position the cam by utilizing the elongated mounting holes. Tighten the mounting screws. Recheck the "Operating Lever Adjusting Screw Adjustment." See Figure 2 for location of parts.

(b) Distributors - The operating cam should be positioned so that the No. 1 marking contacts close when the leading edge of the brush reaches the middle of the third segment to the left of the STOP segment. The marking contacts shall not open until the trailing edge of the brush has passed beyond the end of the No. 5 segment by at least .060".

To adjust, place the main shaft in its stop position and loosen the mounting screws for the outer disk. Move the adjustable disk so that the brush is in the center of the small segment to the left of the STOP segment. Loosen the operating cam mounting screws and position the cam. Tighten screws. See Figures 1 and 7 for location of parts.

NOTE

Be careful when removing the adjustable disk so

that the brushes do not catch in the slots between the segments.

(c) Two-Channel Units (Figures 50 and 51 for location of parts).

1. Rotate the main shaft until the No. 5 contact tongue (outer as regards "A" and "B" transmitter) which leaves its marking (lower) contact first, has just left its marking contact. Check with a low voltage test lamp to determine when the contacts break. At this point, the outside distributor brush should have passed onto the stop segment $1/32''$ to $1/16''$. To adjust, position the operating cam by means of its mounting screws.

2. Rotate the main shaft until the No. 5 contact tongue of the other transmitter has just left its marking (lower) contact. Check with a low voltage test lamp to determine when the contacts break. At this point, the outside distributor brush should not have passed onto the stop segment more than $1/4''$. If this limit has been exceeded, check and refine the adjustments of both transmitters.

(59.1) Tape Lockout Solenoid (For ED59 only) (Figure 66) - With the distributor resting on its side, rotate the main shaft until the operating lever roller is on the high part of its cam. Move the solenoid plunger to its downward position. There should be $.028''$ to $.032''$ clearance between the side of the operating lever and the pin on the solenoid plunger when the play in the plunger is taken up in a direction to provide the maximum clearance. Rotate the plunger to any one position to meet this requirement.

(60) Control Relay Timing Contacts (Figure 51) - See Note (I) on Page 2-1 - To check or make these adjustments it will be necessary to position the operating lever on the high part of its cam.

(a) The heavy contact spring should be straight. Adjust by bending the spring.

(b) The middle or swinger contact spring should be tensioned against the heavy contact spring so that it requires 2-1/2 to 3-1/2 ozs. to just separate the contact points. The tension should be measured with an 8 oz. scale hooked over the middle contact spring at the contact point. To adjust, bend the middle contact spring.

(c) The thin short contact spring should be tensioned against its stiffener so that it requires 1 to 1-1/2 ozs. to just start the spring moving away from its stiffener. The tension should be measured with an 8 oz. scale hooked on the contact spring at the contact point. To

adjust, bend the thin short contact spring.

(d) With the middle contact spring in contact with the heavy contact spring, there should be $.010''$ to $.015''$ clearance between the contact points of the thin contact spring and the middle contact spring. To adjust, bend the thin contact spring stiffener. Recheck the thin contact spring tension.

(e) With the transmitter operating lever on the high part of its cam, there should be $.010''$ to $.015''$ clearance between the insulator on the middle contact spring and the transmitter operating lever. To adjust, position the control relay timing contact bracket by means of its mounting screws.

(61) Transmitter Operating Lever Spring Tension (Figure 51) - See Note (I) on Page 2-1 - Unhook the transmitter operating lever spring from the contact bracket. With the operating lever on the high part of its cam, hook a 32 oz. scale to the spring and pull horizontally. It should require 7 to 12 ozs. to stretch the spring to position length. Rehook the spring.

Make certain that the contact mounting screws clear the transmitter operating lever in all positions of the lever. If no clearance is present readjust the contact springs and bracket.

REMOVE BOTH TRANSMITTER TOP PLATE ASSEMBLIES, KEEPING THEIR RESPECTIVE RIGHT END BRACKETS ASSEMBLED TO THEM FOR IDENTIFICATION.

(62) Lock Pawl ("A" and "B" transmitters) (Figure 52) See Note (I) on Page 2-1 - With the operating lever on the high part of its cam, and the lock pawl in the blocking position, there should be $.020''$ to $.025''$ clearance between the blocking surface of the lock pawl on each transmitter, and the associated blocking surface of the wearing strip. To adjust, position the lock pawl by means of its mounting screw.

(63) Line Shorting Contact ("A" and "B" transmitters) (Figure 53) See Notes (I) and (J) on Page 2-1

NOTE

The contact assemblies should be removed to check these adjustments.

(a) The stiffener of each long contact spring should be straight. Adjust by bending.

(b) The long contact spring should be tensioned so that it requires 1-1/4 to 1-3/4 ozs. to start the spring moving away from its

stiffener. Measure with an 8 oz. scale hooked to the spring at the contact point. To adjust, bend the long contact spring.

(c) Each prong of the short contact spring should be tensioned so that it requires 1/2 to 1 oz. to start each prong moving away from its stiffener. Measure with an 8 oz. scale hooked to the prong at the contact point. Adjust, bend each prong of the short contact spring.

(d) With the long contact spring resting against its stiffener, there should be .020" to .025" clearance between the contact points of the short and long contact springs. To adjust, bend the short contact spring stiffener and recheck the short contact spring tension.

(64) Line Shorting and Transfer Contact Adjustments ("A" and "B" Transmitters) (Figure 54) See Notes (I) and (K) on Page 2-1

NOTE

The contact assemblies should be removed to check these adjustments.

(a) The stiffener of the number 5 contact spring should be straight. To adjust, bend the stiffener.

(b) Each prong of the number 5 contact spring should be tensioned against its stiffener so that it requires 1/4 to 3/4 oz. to start each prong moving away from the stiffener when the number 4 contact spring is held away and an 8 oz. scale is hooked over the spring at the contact point and pulled at right angle to the spring. To adjust, bend the number 5 contact spring.

(c) The number 4 contact spring should be tensioned against the number 5 contact spring so that it requires 3 to 3-1/2 ozs. to separate the contact points when an 8 oz. scale is hooked over the spring at the contact points and pulled at right angle to the contact spring. To adjust, bend the number 4 contact spring. After this adjustment has been made, check to see that the number 4 contact spring holds the number 5 contact spring away from its stiffener .006" to .015".

(d) With the number 4 contact spring resting normally against the number 5 contact spring there should be .020" to .025" clearance between the number 3 and 4 contact points. To adjust, bend the number 3 contact spring stiffener.

(e) Each prong of the number 3 contact spring should be tensioned against its stiffener so that it requires 1/2 to 1 oz. to start

each prong moving away from the stiffener when an 8 oz. scale is hooked over the spring at the contact point and pulled at right angle to the contact spring. To adjust, bend the number 3 contact spring. Recheck the adjustment made under (d) above.

(f) There should be approximately .004" clearance between the insulators of the number 4 and 2 contact springs. To adjust, bend the number 2 contact spring.

(g) There should be .015" to .020" clearance between the number 1 and 2 contact points. To adjust, bend the number 1 contact spring stiffener.

(h) Each prong of the number 1 contact spring should be tensioned against its stiffener so that it requires 1/2 to 1 oz. to start each prong moving away from its stiffener when an 8 oz. scale is hooked over the spring at the contact point and pulled at right angle to the spring. To adjust, bend the number 1 contact spring. Recheck the adjustment made under (g) above.

REPLACE THE CONTACT ASSEMBLIES

With the send-stop lever rotated out of the way of the lock pawl extension, and the lock pawl resting on the long contact spring insulator, there should be .015" to .020" clearance between the lower surface of the lock pawl and the upper surface of the blocking portion of the wearing strip. To adjust, position the contact assemblies by means of their mounting screws. (See Figure 55).

With the send-stop lever in the stop position and lock pawl in the blocking position, an operated long contact spring should move its short contact spring at least .004" away from its stiffener. To adjust, bend the short contact spring stiffener. (See Figure 56 or 57).

(65) Transmission Control Relay Switch Lever Pivot Plate (Figure 55 for location of parts). See Notes (I) and (J) on Page 2-1.

The pivot plate should be positioned to meet the following requirements:

(a) The switch lever yoke should fully engage the switch knob without bending when the switch lever is in either position.

(b) With the switch lever moved to the right, the send-stop lever in the send position, the line shorting contact held away from the lock pawl, and the transmitter operating lever on the high part of its cam, hook a 32 oz.

scale under the lock pawl extension and pull vertically upward. It should require at least 8 ozs. to start the lock pawl moving (Figure 58).

(c) With the switch lever moved to the left, and the lock pawl held out of the blocking position by the line shorting contact, the switch lever springs should have some end play (see Figure 56). To adjust, position the pivot plate by means of its mounting screws.

(66) Send-Stop Lever Spring Tension ("A" and "B" transmitters) (Figure 53) - See Notes (I) and (J) on Page 2-1.

With the lock pawl in the blocking position, the transmitter operating lever on the low part of its cam, the transmission control relay switch lever moved to the left, and the send-stop lever resting on the lock pawl extension, hook a 32 oz. scale under the send-stop lever adjacent to its lobe, and pull vertically upward. It should require at least 10 ozs. to start the send-stop lever moving away from the lock pawl extension.

REPLACE THE TOP PLATE ASSEMBLIES AND THEIR RIGHT END BRACKETS ON THEIR RESPECTIVE TRANSMITTERS

(67) Transmission Control Relay Switch Lever Pivot Plate (See Figure 55 for location of parts) - See Notes (I) and (K) on Page 2-1.

The pivot plate should be positioned to meet the following requirements:

(a) The switch lever yoke should fully engage the switch knob without bending when the switch lever is in either position.

(b) With the switch lever moved to the right, the send-stop lever in the send position, the line-shorting contact held away from the lock pawl, and the transmitter operating lever on the high part of its cam, hook a 32 oz. scale under the lock pawl extension and pull vertically upward. It should require at least 18 ozs. to start the lock pawl moving. (Figure 58).

(c) With the switch lever moved to the left, and the lock pawl held out of the blocking position by the line-shorting contact, the switch lever spring should have some end play. (See Figure 55). To adjust, position the pivot plate by means of its mounting screws.

(68) Send-Stop Lever Spring Tension (Figure 52) - See Notes (i) and (K) on Page 2-1.

With the lock pawl in the blocking

position, the transmitter operating lever on the low part of its cam, the transmission control relay switch lever moved to the left, and the send-stop lever resting on the lock pawl extension, hook a 32 oz. scale under the send-stop lever adjacent to the lobe, and pull vertically upward. It should require at least 18 ozs. to start the send-stop lever moving away from the lock pawl extension.

REPLACE THE TOP PLATE ASSEMBLIES AND THEIR RIGHT END BRACKETS ON THEIR RESPECTIVE TRANSMITTERS.

TRANSMISSION CONTROL RELAY ADJUSTMENTS - See Note (I) on Page 2-1

(69) Contact Springs and Armature Hinge Positions

The contact springs and the hinge brackets should be positioned to meet the following requirements:

(a) All contacts should line up within the limits indicated in Figure 59A.

(b) The spring tangs should rest on the spool head so that the free end of the tang extends back of the front face of the spool head. See Figure 59B.

(c) The width of each spring tang should lie entirely within the projection of the top and bottom edges of the slot in the spool head, but the tang should not rub on the spool head when moved from its normal position of rest on the spool head in the direction of travel of the spring.

(d) The hinge pins should not bind in the holes of the hinge brackets. (See Figure 59C).

(e) With the A spring tensions (see Figure 59D) approximately equal (if not, adjust as per paragraph 74a under Contact Spring Adjustments) both legs of the armature should bear against the hinge bracket when the relay is in the operated position and should also bear against the hinge bracket after the relay has been released. To adjust, slightly loosen the contact spring mounting screws and position the springs and the hinged brackets. Tighten the mounting screws.

(70) Adjusting Stud Clearance

There should be some clearance between the armature and the adjusting stud over the entire armature travel. Bend the stud with a pair of long nose pliers to obtain this clearance.

(71) Adjusting Nut Tightness

The adjusting nut should be sufficiently tight on the stud to prevent its being readily turned with the thumb and forefinger. To adjust, back off the adjusting nut from the adjusting stud until its slotted portion is free of the stud, then force the slotted parts of the nut closer together, using a pair of long nose pliers.

(72) Armature Travel (Figure 59C)

There should be .062" to .068" clearance between the armature stop pins and the core. To adjust, turn the adjusting nut.

(73) Contact Spring Tension

The springs should be tensioned toward the armature. All spring tensions should be measured with the armature in the unoperated position except where the abbreviation "arm. oper." is shown.

(a) The A springs should have approximately the same tension and should hold the armature against the adjusting nut. It should require a pressure of 20 to 45 grams applied to the back of the armature at a point approximately midway between the stop pins to start the armature moving away from the adjusting nut. Adjust by bending the A contact springs.

(b) The C and H contact springs should be tensioned so that it requires a pressure of 30 to 50 grams (applied to the tip just in front of the contacts) to start the tang of each spring moving away from the side of the slot in the spool head next to the armature (some are measured with the armature in the operated position). Adjust by bending the C and H contact springs.

(c) The G contact spring should be tensioned toward the armature so that it requires a pressure of 5 to 20 grams (applied at the tip of the spring) to start its operating stud moving away from its operating spring. Adjust by bending the G spring.

(d) The E contact spring should be tensioned toward the armature so that it requires a pressure of 30 to 50 grams (applied to both prongs at the tip of the spring) to start its contacts moving away from its associated C break contacts. Adjust by bending the E spring.

(e) Each B and J contact spring should be tensioned toward the armature and together with the tensions of any G springs which may in turn be tensioned against it, should require a pressure of 20 to 40 grams (applied to both prongs at the tip of the spring) to start its contacts away from its associated C break contacts. Adjust by bending the B and J contact springs.

(74) Stud Gap

With the armature unoperated, there should be at least .006" clearance between the end of the armature operated stud and the B spring. To adjust, bend the associated C break contact spring tang and recheck its spring pressure. Recheck the B contact spring pressure.

(75) Contact Sequence

On break-make contacts of the spring combinations, the normally closed contacts should break before the normally open contacts make. Gauge by eye. Adjust by modifying the spring tensions, stud gaps and contact adjustments as required.

(76) Contact Make

Both contacts of the B bifurcated springs should make with their associated C break springs when the armature is in the unoperated position; they should also make contact with their associated C make contact springs when the relay is electrically energized. To adjust, bend the ends of the springs (obtain by bending only the ends of the B springs if possible). Recheck the spring pressures and the stud gap.

(b) Both contacts of the A and H contact springs should make with their associated C springs when the armature is in the operated position. To adjust, bend the bifurcated spring ends and recheck the spring pressures.

(c) Both contacts of the E spring should make with the C spring when the armature is in the unoperated position and both contacts of the G spring should make with the E spring when the armature is in the operated position. To adjust, bend the ends of the springs (obtain by bending only the ends of the E springs if possible). Recheck the spring pressures.

(d) Each of contact springs A, B, and H should meet the following requirements:

1. With the relay electrically energized against a gauge of .040" thickness, none of the make contacts should make contact with a mating contact on an associated H contact spring.

2. With the relay electrically energized against a gauge of .003" thickness, at least one of the contacts on each make contact spring should make contact with its mating contact on an associated H contact spring.

3. With the relay electrically energized against a gauge of .016" thickness,

none of the make contacts should make contact with a mating contact on an associated C make contact spring.

4. With the relay electrically energized against a gauge of .009" thickness, at least one of the make contact on each A and B contact spring should make contact with its mating contact on the associated C make contact spring.

5. With the relay electrically energized against a .005" gauge inserted between the armature and the core, both break contacts on each B spring should be separated from their mating contacts. To adjust, bend the tang on the associated C contact springs and recheck their pressures.

(e) Contact springs G, E, J, and their associated C contact springs should meet the following requirements:

1. With the relay unoperated, the contact separation designated U should be at least .010", and there should be a slight clearance at the points S. See Figure 59.

2. With the relay electrically energized against a .020" gauge, the J contact should not leave its associated C contact spring.

3. When the relay is electrically energized against a .055" gauge inserted between the armature and the core, both break contacts on the E and J contact springs should be separated from their mating contacts on the C springs. To adjust, bend the tang on the associated C break contact spring and recheck the spring pressure.

NOTE

The relay is designed to operate on .0325 amperes of current.

END OF TRANSMISSION CONTROL RELAY ADJUSTMENTS

(77) Main-Shaft Clutch Torque - See Note (C) on Page 2-1

(a) Transmitter Distributor

With the motor running, it should require a pull of 28 to 32 ozs. to hold the brush arm stationary when a 32 oz. scale is hooked over the stop-cam lug as shown in Figure 27.

(b) Distributor

With the motor running, it

should require a pull of 32 to 36 ozs. to hold the brush arm stationary when a 64 oz. scale is hooked over the stop-cam lug (Figure 21).

This measurement should be made when the unit is warm from recent operation; otherwise, the unit should be operated for at least ten minutes with the friction clutch slipping before the measurement is made. The operating cam should be relieved of the operating arm load during torque measurement. This may be done by removing the base plate and removing the operating arm. To adjust the clutch torque, loosen the adjustable clutch-disk lock nut and turn the disk clockwise to increase the torque or counter-clockwise to decrease the torque. Hold the disk and tighten the lock nut against it. Use a 76289 spanner wrench. See Figure 4 for location of parts.

NOTE

When observing transmitter distributor (meeting 28 to 32 oz. friction clutch torque) signals on DXD units, to eliminate the signal drift insert a small wood wedge lightly between the clutch nut (77012) and the friction disk (77018). The wedge should be small enough to clear the motor pinion during shaft rotation and should be removed for normal operation of the friction clutch. Usage of the wedge during observation of the transmitted signals should make it unnecessary to raise the friction clutch torque and will provide the desired signal form from the transmitter distributor to a (DXD) signal distortion test set. When wedge is removed and a pronounced drift is observed on scope the clutch torque should be rechecked.

(c) Signal Distortion Test Set (Figure 88A)

When the motor has operated for at least ten minutes with the brush arm stationary, it should require 18 to 20 ozs. to hold the brush arm stationary when a 32 oz. scale is hooked over the end of the brush arm. To adjust, loosen the adjustable disk lock nut and turn the disk clockwise to increase the torque and counterclockwise to decrease the torque. Hold the disk and tighten the lock nut against it.

NOTE

This adjustment must be made by means of an 101082 offset wrench and a 76289 spanner wrench. Make certain that the nut and disk are securely tightened against each other.

THE FOLLOWING ADJUSTMENTS PERTAIN TO SIX UNIT TRANSMITTER DISTRIBUTORS EQUIPPED WITH A RUBOUT DELETING MECHANISM. UNITS SO EQUIPPED CAN BE RECOGNIZED BY THE RUBOUT BAIL PRESENSING

PINS ADJACENT TO THE REGULAR TAPE SENSING PINS

NOTE

The rollers on the operating lever and lever assembly should engage full width of their respective cams. To adjust, loosen cam mounting screw, position cam and tighten cam mounting screw.

(78) Rubout Bail Position

With the tape between the transmitter distributor gate and the feed roll drawn taut, the butout bail sensing pins should just clear the leading edge of the perforations in the tape and simultaneously be in line with the regular tape sensing pins when sensing a rubout. To adjust, loosen the rubout bail shaft mounting screws and position the rubout bail shaft to obtain the requirements. Tighten screws, and recheck.

(79) Control Assembly Contact Spring Clearance and Tension (Figure 61)

There should be some, not more than .010", clearance between the contact spring insulating extension and the contact insulating button. To adjust, bend the thick contact spring farthest away from the mounting bracket. Hook an 8 oz. scale on each contact spring in line with the associated contact. It should require 2 to 4 oz. to just open each set of contacts. To adjust, bend the contact springs.

(80) Control Assembly Cam Follower Position

The control assembly cam follower should engage the full width of the control cam. To adjust, position the pile-up with respect to the mounting bracket.

(81) Control Assembly Position (Figure 63)

(a) When the cam follower is approximately halfway down the slope of its cam, the trailing edge of the distributor brush should be clear of the sixth segment and the leading edge of the distributor brush should just be entering the leading edge of the stop segment.

NOTE

It may be necessary to reposition the cam assembly 180 degrees.

(b) With the cam follower on the highest part of its cam, there should be .015" to .025" clearance between contact points.

(c) To adjust, loosen control assembly mounting nuts and position to meet both of the preceding requirements. Tighten nuts and recheck.

(82) Rubout Lever Mounting Bracket

The rubout sensing pins should start to move downward simultaneously with the regular tape sensing pins. To adjust, loosen the 126942 bracket mounting screws and position the bracket in the elongated mounting holes.

(83) Rubout Lever Adjusting Screw (Figure 60)

With the rubout lever roller on the lowest portion of its cam and the rubout bail manually operated to provide maximum elevation of its sensing pins above the transmitter tape guide plate, the lowest sensing pin should be .010" to .015" below the top of the tape guide. To adjust, loosen the rubout lever adjusting screw nut and position the adjusting screw to meet the requirement. Tighten the nut and recheck the clearance.

(84) Rubout Contact (Figure 64)

(a) With the push end of an 8 oz. scale applied in line with the contact point, it should require 1 to 3 oz. to start the inner contact spring moving away from its stiffener. To adjust, bend the inner contact spring.

(b) With the rubout bail lower extension held away from the contact spring, there should be .010" to .020" clearance between contact points. To adjust, bend the outer contact spring.

(85) Rubout Contact Assembly (Figure 60)

When rotating the motor fan wheel by hand in the direction of normal motor rotation the rubout contacts should not open until after both control assembly contacts have closed. To adjust, position the rubout contact assembly in its elongated holes in the top plate, tighten screws.

(86) Control Relay (Figure 62)

(a) When both contact points are just touching, there should be .005" to .010" clearance between the armature and core at the closest point. To adjust, bend the contact springs.

(b) With the armature against its backstop, there should be .020" to .030" clearance between contact points. To adjust, bend the backstop.

(c) Position the relay so that the armature spring is lying horizontally on the underside of the relay and apply the push end of an 8 oz. scale horizontally to the armature just

below the backstop. It should require between 1/2 to 1 oz. to hold both points just touching. To adjust, bend the armature spring mounting bracket.

(87) Rubout Bail Spring Tension (Figure 65)

Hook a 32 oz. scale over the spring post and pull in line with the spring. With the rubout bail cam follower on the low part of the cam and the presensing contacts held away from the rubout bail lower extension, it should require 8 to 10 ozs. to just move the rubout ball.

(88) Intermediate Lever Spring Tension (Figure 65)

Unhook the spring and insert an 8 oz. scale in the spring eye. With the rubout cam follower on the low portion of the cam, it should require 3 to 5 oz. to stretch the spring to installed length.

REPLACE THE TRANSMITTER LEFT BRACKET, TOP COVER, SNAP PANEL, AND THE TRANSMITTER-DISTRIBUTOR BASE PLATE.

(89) Control Switch (Figure 85) - See Note (N) on Page 2-1.

(a) The control switch knob set screw should engage the flat on the switch shaft and there should be some clearance not over 1/16", between the knob and the scale throughout the semi-circle of rotation of the knob. To adjust, loosen the knob set screw and position the knob. Tighten the set screw. (Figure 85A).

(b) With the detent cam set screw engaging the flat on the switch shaft and the detent roller in the center indent of the detent cam, the indicator of the knob should point to ZERO on the scale. Adjust by means of the detent lever eccentric shoulder screw (Figure 85B).

(c) With adjustments (a) and (b) properly made, the contact cam set screws should be in line with the detent cam set screw. To adjust, loosen the contact cam set screws and position the cam. Tighten the set screws (Figure 85A).

(d) Hook a 32 oz. scale over the detent roller and pull in line with the detent lever spring. It should require 15 to 20 ozs. (19 to 28 ozs. for units equipped with spring bracket) to start the detent lever moving away from the detent cam (Figure 85B).

NOTE

If necessary, loosen the mounting screws of the

spring bracket and take up the play in the bracket mounting holes in the required direction to meet the spring tension requirement. Tighten the spring bracket mounting screws.

(90) Control Switch Contact Spring (Figure 86) - See Note (N) on Page 2-1

NOTE

The control switch contact spring adjustments are very stable and should not require attention or readjustment unless the control switch assembly is removed. In order to make adjustments without dismantling the assembly, spring bender 79002 is required.

(a) Facing the right-hand side of the unit with the switch knob in the zero position, the contacts of the pile-ups (numbered 1 to 8, from left to right) should be as follows:

- 1 - All Open
- 2 - All Open
- 3 - Open
- 4 - Back Closed - Front Open
- 5 - Back Closed - Front Open
- 6 - Back Closed - Front Open
- 7 - Back Closed - Front Open
- 8 - Open

(b) With the switch knob in the zero position, all eight cam follower springs should bear against the cam with some pressure, not more than 1 oz. To measure this pressure, hook an 8 oz. scale over the upper end of the spring, at the cam, and pull at a right angle to the springs. Adjust by bending the cam follower springs.

NOTE

Hold the long contact springs (swingers) away from the cam follower spring while measuring the pressure.

(c) With the switch knob in the zero position, the long contact springs (swingers) should bear against the cam follower spring, or the next inner long contact spring (swinger), with 1-1/2 to 3 ozs. pressure. To measure this pressure, hook an 8 oz. scale over the upper end of the long contact springs (swingers) and pull at right angles to the springs. Adjust by bending the long contact springs.

NOTE

Hold the short contact springs and the outer long contact springs (swingers) out of the way while measuring the tension of the inner long contact springs (swingers).

(d) With the switch knob horizon-

tally to the right, the contacts which were closed in paragraph (a) should now have a contact gap of .015" to .025". Adjust by bending the short contact springs.

(e) With the switch knob in the zero position, the contacts which are open (refer to paragraph (a)) should have a contact gap of .015" to .025". Adjust by bending the short contact springs.

(91) Signal Distortion Calibration - See Note (N) on Page 2-1

When brushes on the segmented rings are readjusted or replaced or when the pointer mounted on the control switch contact guard has been removed (Figure 1A), the adjustment of the pointer should be rechecked as follows:

Insert the signal distortion test set into a slip connection base plate which is connected to the proper power supply for the motor and tape stop magnet circuits. Connect a Teletype DXD signal distortion test set (code disk operated with stroboscope) to the proper power supply for the motor, and connect the stroboscope of the test set in series with the distributor signal circuit and a 110 volt d. c. source. Set the DXD test set control switches as follows:

<u>Switch</u>	<u>Position</u>
Bias-Zero-End Distortion	Zero
Mark-Zero-Space	Zero
View-Transmit	View
Line-Distributor	Line
Motor	On
Increase Distortion	Any Position
Run-Stop	Stop
R-Test Message-Y	Any Position

Set the filter cutout switch of the tape operated test set so that the filter is "OUT." Adjust the three outer disk clamping plates by means of their mounting screws, so that the outer disk is held friction tight (Figure 1). Insert a piece of tape perforated with a series of "R" combinations in the transmitter and turn the control switch knob to the "Bias-M" position.

With the tape operated test set and the DXD test set both operating at the same speed, move the scale on the test set so that the start pulse "zero" indication on the scale is in line with the beginning of the transmitted start pulse from the tape operated test set, as indicated by the end of the light image on the stroboscope.

NOTE

If the image on the stroboscope appears dim,

reverse the d. c. connections to the signal circuit.

Position the adjustable disk on the distributor of the tape operated test set so that the image on the stroboscope which indicates the length of the stop impulse, extends from "75" on the fifth segment to "142" on the stop segment. Stop the distributor and clamp the adjustable disk in this position by tightening the three clamp screws. Then position the calibration pointer mounted on the control switch contact guard so that it points to "25" on the calibration scale located on the periphery of the adjustable distributor disk (Figure 1A). Remake the Operating Cam Adjustment paragraph (59).

THE FOLLOWING TWO ADJUSTMENTS PERTAIN TO UNITS EQUIPPED WITH AN END-OF-TAPE STOP MECHANISM. THIS MECHANISM CONSISTS OF A PAIR OF CONTACTS MOUNTED UNDER THE TAPE GUIDE, WIRED IN SERIES WITH THE TAPE STOP MAGNET AND OPERABLE BY A PIN WHICH PROJECTS THROUGH THE TAPE GUIDE.

(92) End - Of - Tape Stop - Contact - Pin Guide (Figure 67) - See Note (A) on Page 2-1

(a) If the unit is equipped with the old style (97445 - Figure 68A) retainer lid and the old style (97468 - Figure 69A) tape-guide plate, adjust as follows: (Note: This combination is not recommended when spliced chadless tape is to be used.) There should be .010" to .020" clearance between the end-of-tape stop pin and the shoulder of the tape guide plate when the side play of the pin is taken up in a direction to make this clearance a minimum. To adjust, loosen the stop-pin guide mounting screws and position the guide. Locate the feed-wheel shaft bearing so that the feed-wheel shaft is free with not over .002" end play before tightening the screws.

(b) If the new style (111628 - Figure 68B) retainer lid and new style (111627 - Figure 69B) tape-guide plate are used together, adjust as follows: (Note: This combination may be used for regular, chadless, or spliced chadless tape.) The end-of-tape stop contact pin should be centrally located in the contact-pin guide clearance hole of the retainer lid. Gauge by eye. To adjust, loosen the stop-contact pin-guide mounting screws and position the guide. Locate the feed-wheel-shaft bearings so that the feed-wheel shaft is free with not more than .002" end play before tightening the mounting screws.

(c) If the old style (97445 - Figure 68A) retainer lid and new style (111627 - Figure 69B) tape-guide plate are used together, adjust

as follows: (Note: This combination is not recommended when spliced chadless tape is used). There should be .010" to .020" clearance between the end-of-tape stop contact pin and the side of a straight edge which is placed on the front shoulder of the tape guide so that it lines up with the inner edge of the shoulder. To adjust, loosen the stop-pin guide mounting screws and position the guide. Locate the feed-wheel-shaft bearings so that the feed-wheel shaft is free with not more than .002" end play before tightening the mounting screws.

NOTE

The 111628 (Figure 68B) retainer lid and 97468 (Figure 69A) tape-guide cannot be used together.

(93) End-Of-Tape Stop-Contact-Spring

(a) Place a straight edge across the top of the tape-guide plate, directly over the end-of-tape stop pin. There should be .020" to .025" clearance between the bottom of the straight edge and the upper end of the stop pin. To adjust, bend the upper contact spring.

(b) When the lower contact spring is resting against its stiffener, the contact points should be separated by .008" to .012". To adjust, bend the lower contact spring stiffener.

(c) Place a piece of tape in the guide and close the tape-retaining lid. It should require a pressure of 20 to 25 grams (applied at the contact point of the lower contact spring) to just open the contact points. To adjust, bend the lower contact spring. Remove the tape and recheck adjustment (b).

ADJUSTMENTS FOR THE SINGLE STEP TAPE FEED SUPPRESSION MECHANISM

(94) Tape Feed Lever Latch (Figure 70)

With the operating lever roller on the peak of its cam and the latching tooth on tape feed lever latch held in line with the edge of the tape feed lever extension, there should be .005" to .020" clearance between the tape feed lever latch and the tape feed lever extension. To adjust, increase or decrease the number of shims between the lever mounting bracket and the distributor base casting.

(95) Trip-Off Latch Eccentric (Figure 71)

With the operating lever roller on the peak of its cam and the trip-off latch locked by the trip-off lever, there should be approxi-

mately .062" between the tape feed lever extension and the tape feed lever latch as indicated in Figure 70 - gauge by eye. To adjust, loosen the trip-off latch eccentric lock nut and position the eccentric. Tighten the lock nut.

(96) Restoring Lever Eccentric (Figure 70)

(a) With the operating lever roller on the peak of its cam and the trip-off latch released (Figure 72), there should be .020" to .035" clearance between the lower edge of the step on the end of the restoring lever and the upper edge of the restoring blade. To adjust, position the restoring lever eccentric screw.

(b) When resetting, hold the operating lever against the operating cam and check to determine that the trip-off latch extension is carried at least .010" below the latching tooth on the non-repeat lever. If necessary, refine the original adjustment above to meet this requirement.

NOTE

If this adjustment cannot be fully made by the eccentric, position the restoring blade up or down by means of its elongated mounting holes.

(97) Restoring Lever Plate (Figure 73)

With the main shaft in the stop position, trip the clutch stop lever and rotate the motor governor or fan until the operating lever roller reaches the low part of its cam. Then manually hold the trip-off lever down and slowly rotate the motor governor or fan until the restoring lever just drops into the path of the restoring blade. With this condition set up, position the adjustment plate so that there is .025" to .035" clearance between the face of the restoring blade and the face of the adjustment plate on the restoring lever.

(98) Trip-Off Lever Spring Tension (Figure 72)

With the trip-off latch unlocked, unhook the non-repeat lever spring. It should require from 4 to 6 ozs. to start the trip-off lever moving when an 8 oz. scale is hooked to the lever in line with the upper spring hole of the lever and pulled horizontally. Rehook the non-repeat lever spring.

(99) Non-Repeat Lever Spring Tension (Figure 74)

With the trip-off latch in the unlocked position, it should require from 1 to 2

ozs. to start the non-repeat lever moving when the push end of an 8 oz. scale is placed against the lever just below the spring and pushed horizontally.

(100) Tape Feed Lever Latch Spring Tension (Figure 74)

With the trip-off latch in its locked position and the feed lever latch against its eccentric, apply the push end of an 8 oz. scale and push horizontally against the spring post of the feed lever latch. It should require from 1/2 to 1-1/2 ozs. to start the latch moving.

(101) Restoring Lever Spring Tension (Figure 74)

With the transmitter distributor in its stopped position and the trip-off latch in the locked position, it should require 2 to 3-1/2 ozs. to start the restoring lever moving when an 8 oz. scale is hooked on the lever in line with the spring and pulled horizontally.

(102) Trip - Off Latch Spring Tension (Figure 74)

With the unit on its left side and the trip-off latch in its locked position unhook the trip-off latch spring. With 32 oz. scale inserted through the hole in the bottom of the base casting and hooked in the loop of the spring, it should require 8 to 11 ozs. to stretch the spring to position length. Rehook the spring.

(103) Restoring Bail Spring Tension (Figure 74)

With the transmitter distributor in the stopped position unhook the restoring bail spring. With a 4 lb. scale hooked in the spring loop and pulled horizontally, it should require 28 to 32 ozs. to pull the spring to position length. Rehook the spring.

THE FOLLOWING ADJUSTMENT PERTAINS TO TRANSMITTER DISTRIBUTORS EQUIPPED WITH A TAPE GUIDE WIRE AS ILLUSTRATED IN FIGURE 42 - See Note (G) on Page 2-1

(104) Tape Guide Wire (Figure 42)

With the tight-tape stop (or auto-stop lever resting in its horizontal position, the lower side of the righthand portion of the tape guide wire should be even with the lower side of the lever, and there should be a clearance of .020" to .080" between them. To adjust, loosen the tape guide wire mounting screws and position the guide. Tighten the mounting screws.

NOTE

In transporting this unit, the tape guide wire and

the tight-tape stop lever should be removed. Remove the latter by loosening its lock nut and unscrewing the lever from its clamp. When re-assembling the tape guide wire, it will be necessary to remake this adjustment.

THE FOLLOWING ADJUSTMENTS PERTAIN TO TRANSMITTER DISTRIBUTORS EQUIPPED WITH THE BELL-ON-BLANK SIGNAL MECHANISM, A MECHANISM FOR TRANSMITTING THE BLANK COMBINATION WITHOUT SPACING TAPE. TRANSMITTER DISTRIBUTORS EQUIPPED WITH THIS MECHANISM HAVE A LEVER PROTRUDING FROM THE FRONT PANEL OF THE TRANSMITTER NEAR THE TOGGLE SWITCH. THE MECHANISM SHOULD BE ADJUSTED AS FOLLOWS:

(105) Contact Operating - Lever Latch (Figure 75)

The edges of the contact operating-lever latch should be parallel to the edges of the contact operating lever. To adjust, loosen the contact operating-lever latch mounting screws and position the latch. Tighten the screws.

(106) Contact Operating-Lever Bracket (Figure 75) - See Note (D) on Page 2-1

Move the transmitter operating lever to a position to bring the adjusting screw lock nut nearest the contact operating-lever latch. There should be .015" to .025" clearance between the point on the latch and the adjusting screw lock nut. To adjust, loosen the contact operating-lever bracket mounting studs and position the bracket. Tighten the studs.

(107) Contact Operating - Lever Latch Overtravel (Figure 75) - See Note (D) on Page 2-1.

With the main shaft in its stop position (lug on the stop cam engaged by the stop arm), the transmitter operating-lever adjusting-screw lock nut should overtravel the latch .010" to .015". To adjust, loosen the contact operating-lever latch mounting screws and position the latch. Tighten the screws, making certain that the edges of the latch are parallel to the edges of the contact operating lever.

(108) Contact (Figure 76) - Does not apply to Transmitter Distributors having a separate pair of contacts for the release magnet circuit which permits the release magnet to be used on either a. c. or d. c.

(a) The insulator on the outer contact spring should rest against the finger on the contact operating lever with a very slight amount

of tension. Adjust by bending the outer contact spring (with insulator).

(b) There should be a gap of .010" to .015" between the contact points on the middle and outer (with insulator) contact springs. When checking this adjustment, the outer contact spring (without insulator) should not bear against the middle contact spring. Adjust by bending the middle contact spring.

(c) There should be a gap of .010" to .015" between the contact points on the middle and outer (without insulator) contact springs. Adjust by bending the outer contact spring (without insulator).

(109) Bell-On-Blank (Figure 77) - Applies only to Transmitter Distributors having a separate pair of contacts for the release magnet circuit which permits the release magnet to be used on either a. c. or d. c.

(a) With No. 2 contact spring held away from the No. 4 contact spring, the insulator on No. 4 contact spring should rest against the finger on the contact operating lever with a very slight amount of tension. To adjust, bend the No. 4 contact spring.

(b) There should be a contact gap of .010" to .015" between the contact points of No. 3 and No. 4 contact springs. To adjust, bend the contact stiffener associated with No. 3 contact spring.

(c) Apply the push end of an 8 oz. scale to No. 3 contact spring near the contact point. It should require 2 to 4 ozs. to start the contact spring moving away from its stiffener. To adjust, bend the No. 3 contact spring.

(d) The insulator of No. 2 contact spring should rest against the insulator of No. 4 contact spring with a very slight amount of pressure. To adjust, bend the No. 2 contact spring.

(e) There should be a gap of .010" to .015" between the contact points of No. 1 and No. 2 contact springs. To adjust, bend the No. 1 contact spring stiffener.

(f) Apply the push end of an 8 oz. scale to the No. 1 contact spring near the contact point. It should require 2 to 4 ozs. to start the contact spring moving away from its stiffener. To adjust, bend the No. 1 contact spring.

(110) Contact Operating - Lever Spring Tension (Figure 76)

Hook an 8 oz. scale over the contact operating-lever latch, just opposite the notch, and pull horizontally and as nearly as pos-

sible at right angle to the contact operating lever. Holding the contact-spring insulator away from the finger on the contact operating lever, it should require 5 to 8 ozs. to start the lever moving.

(111) Break-Relay Armature Yoke (Figure 78A) - See Note (E) on Page 2-1.

Loosen the residual-screw lock nut and backoff the residual screw so that it will not touch the magnet core. There should be .002" to .004" clearance between the inner surface of the armature and the heel piece when the armature is against the magnet core. To adjust, loosen the armature-yoke mounting screw and position the yoke. Tighten the mounting screw.

(112) Residual Screw (Figure 78B) - See Note (E) on Page 2-1.

There should be .002" to .003" clearance between the armature and the magnet core when the armature is held operative. To adjust, loosen the residual-screw lock nut and position the screw. Tighten the lock nut.

(113) Break-Relay Contact (Figure 78C) See Note (E) on Page 2-1.

(a) The wide contact spring should be parallel to the heel piece and the contact points should be evenly aligned. To adjust, loosen the contact-pile-up mounting screws and position the contact springs. Tighten the screws.

(b) Hook an 8 oz. scale over the upper end of the narrow contact spring and pull horizontally at right angle to the contact spring. With the armature arm held against the backstop, it should require 3/4 to 1-1/4 ozs. to start the narrow contact spring moving. To adjust, bend the narrow contact spring.

(114) Armature Arm - See Note (E) on Page 2-1.

(a) The contacts should open when the armature is held operated with a .004" gauge inserted between the residual screw and the magnet core.

(b) The contacts should not open when the armature is held operated with a .006" gauge inserted between the residual screw and the magnet core.

(c) Adjust for the above requirements by bending the armature arm.

(115) Armature Arm Backstop (Figure 78C) - See Note (E) on Page 2-1.

(a) The armature arm should have a slight amount of play, not more than .004", between the backstop and the narrow contact spring. Adjust by bending the armature-arm backstop.

(b) Recheck the narrow contact spring tension. If it is necessary to readjust the tension, recheck the armature arm and backstop adjustments.

END OF BELL - ON - BLANK ADJUSTMENTS

THE FOLLOWING TWO ADJUSTMENTS PERTAIN TO TRANSMITTER DISTRIBUTORS EQUIPPED WITH A. C. - GOVERNED MOTORS PROVIDED WITH A GOVERNOR SPARK-PROTECTION CONTACT ASSEMBLY MOUNTED ON THE DISTRIBUTOR-SHAFT BEARING BRACKET. THE CONTACT ASSEMBLY SHOULD BE ADJUSTED AS FOLLOWS:

(116) Stop-Arm Contact Spring Tension (Figure 79A)

Hook an 8 oz. scale over the end of the contact and pull horizontally away from the stop arm. It should require 2 to 2-3/4 ozs. to just separate the contact points. When checking this adjustment, make sure that the bakelite extension on the contact spring does not touch the stop arm. Shift the contact bracket, if necessary. Adjust the tension of the contact spring by bending.

(117) Stop-Arm Contact Gap (Figure 79B)

The contact points should have a gap of .015" to .020" when the stop magnet armature is held against the magnet cores. To adjust, loosen the contact-bracket mounting screws and position the bracket. Tighten the screws.

THE FOLLOWING ADJUSTMENTS APPLY TO TRANSMITTER DISTRIBUTORS EQUIPPED WITH THE TORN FEED HOLE TAPE STOP ASSEMBLY.

(118) Feed Wheel Shaft Bearings - Same as standard adjustment.

(119) Detent Lever Spring Tension (Figure 32) - Same as standard adjustment.

(120) Tape Retaining Lid Latch Wearing Strip Shims (Figure 33) - Same as standard adjustment.

(121) Tape Space (Figure 34) - Same as standard adjustment.

(122) Tape Finger (Figure 80)

The clearance between the tape

fingers and tape guide plate should be .011" to .016", when the retaining lid is latched and play is taken up in a direction for minimum clearance. To adjust, remove or add shims between the tape fingers and retaining lid plate. The fingers may be bent if necessary.

(123) Tape Retaining Lid Plate (Figure 34)

Place a piece of chadless tape in the tape guide, (engage the feed holes on the pins of the feed roll and feed wheel) and close lid. The edges of the plate should be parallel to the shoulders of the tape guide and when the feed roll is rotated the retaining lid plate should not interfere with the lids of the chadless tape when the lids are raised. The feed wheel should be centered in the slot of the tape finger so that chad lids are free of interference from sides of slots on the tape finger. To adjust, loosen the retaining lid plate mounting screws and position the plate and tape finger. Tighten the screws.

(124) Tape Guide (Figure 35) - Same as standard adjustment.

(125) Retaining Lid Latch Spring - Same as standard adjustment.

(126) Detent Bracket (Figure 35) - Same as standard adjustment.

(127) End-Of-Tape Stop Contact Spring (Figure 14)

(a) With the contact operating arm on the low part of its cams (notches in cams aligned) hold contact operating arm against cam; it should require 6 to 15 grams applied to the end of the insulator of the upper contact spring to move insulator away from the arm. To adjust, bend upper contact spring.

(b) With the contact operating arm on the low part of its cams and the lower contact spring resting against its stiffener, there should be .025" to .040" gap between the contacts. To adjust, bend the lower contact spring stiffener.

(c) With the contact operating arm on the high part of its cam, it should require 20 to 40 grams applied at the contact points of the lower contact spring to just open the contact points. To adjust, bend the lower contact spring.

(128) Operating Instructions - For the Torn Feed Hole Tape Stop Mechanism

Before attempting to start or re-start the transmitter distributor equipped with the torn feed hole tape stop assembly, first turn the clutch magnet switch to the "OFF" position.

Position new tape or reposition torn tape beyond the damaged section so that the tape feed holes mesh with both the feed roll and the feed wheel pins in the tape guide. Latch tape lid. Then reset the mechanism by turning the reset wheel in the counterclockwise direction as far as it will go freely (when facing the switch end of the transmitter). Turn the transmitter distributor clutch switch to the "ON" position to start transmission.

END OF TORN FEED HOLE TAPE STOP MECHANISM

EXTERNAL CIRCUIT CONTROL CONTACT MECHANISM ADJUSTMENTS

(129) Contact Spring Tension (Figure 87)

Hook an 8 oz. scale over the long contact spring just above the contact point and pull horizontally at a right angle to the spring. It should require 3 to 4 ozs. to separate the contacts. The transmitter operating lever should not interfere with the contact spring insulator when this tension is measured.

(130) Contact Clearance (Figure 87)

Locate the distributor shaft so that the outer brush has just moved from the "stop" to the "start" segment. With the shaft in this position locate the contact mounting bracket so that there is barely perceptible clearance between the contact points; tighten the mounting screws.

NOTE

With the operating lever roller on the low part of the cam the contact gap should be at least .015". If this clearance does not exist, readjust the operating cam within the limits provided in the standard adjustments until the required clearance is obtained.

(131) Operating Lever Spring Tension

Unhook the operating lever spring from the extension of the contact mounting bracket. With the operating lever roller on the peak of its cam it should require 3 to 5 ozs. to stretch the spring to its installed length. Rehook the spring.

b. SYNCHRONOUS MOTORS - STARTING SWITCH

(1) The following requirements should not be checked unless there is reason to believe that the starting switch is out of adjustment.

(a) Remove the motor unit from

the base and remove the motor fan and pinion.

(b) Remove the switch end-shield screws and the switch-commutator mounting screws. Remove the switch end shield.

(c) Pull out the rotor until the brush holder spring is accessible and remove the spring.

(d) The tension of the spring for 60-cycle motors should measure 2 to 2-1/2 ozs. when extended to a length of five inches, using an 8 oz. scale. The tension of the spring for 50-cycle motors should measure 1-3/4 to 2 ozs. when extended to a length of five inches.

(e) The brush holders should be mounted by means of the center set of mounting holes and should be free.

(f) The brush-holder stop pins should be safely within the holes of the fiber disk when all the play in the brush holders has been taken up to make the engagement of the pins with the disk a minimum.

(g) Replace the brush-holder spring, making certain that the springs eyes are fully engaged with each other.

(h) Replace the switch-commutator screws and tighten the two screws alternately a little at a time until both screws are tight.

(i) Replace the switch end-shield screws, using the same precaution in tightening as above.

(j) Apply the push end of a 12 lb. scale against the fan end of the shaft and push parallel to the shaft. It should require at least 7 lbs. pressure to start the shaft moving.

(k) Replace the motor fan and pinion. Replace the motor unit on the base and re-make the motor position adjustment.

c. GOVERNED MOTORS

(1) Motor Armature Thrust Spring Compression (Figure 82)

Apply the push end of a twelve pound scale horizontally against the governor outer contact disk and push toward the pinion end of the motor. It should require at least seven pounds to start to overcome the compression of the armature spring.

REMOVE THE BRUSH SPRING PLATE AND GOVERNOR COVER

REMOVE THE SPEED ADJUSTING SPRING

(2) Governor Shell (Figure 81)

(a) The governor contact points should meet squarely and there should be at least .010" clearance between the governor spring bracket and the rim of the governor shell. To adjust, remove the governor from its shaft and position the governor spring bracket by means of its mounting screws.

NOTE

If necessary, reposition the "fixed contact" bracket to facilitate squaring up the contacts.

(b) There should be a gap of .015" to .040" between the governor contacts. To adjust, bend the governor contact spring.

REPLACE THE SPEED ADJUSTING SPRING

(3) Governor

There are two types of slip rings in use on governors, the peripheral ring and the end ring. The five adjustments immediately following are common to both types.

(a) Adjustments for Alignment and Squareness of Governor Contacts

1. All governor contacts can be adjusted for alignment of edges; only those governor shells which provide elongated mounting holes for the fixed contact bracket permit adjustment of the contact for height by positioning the contact bracket.

2. The governor contacts should be in line and meet squarely so that maximum contact surface is provided. (Check with the retractile spring tension adjusted so that the contacts just make, or to the limit of the adjusting screw.)

a. Line up edges of contacts by means of the floating-contact-hinge mounting screw.

b. Adjust contacts for squareness from right to left by positioning the height of the fixed contact bracket using the elongated mounting holes in the governor shell.

c. To adjust from front to back, twist the floating-contact-hinge, applying pressure to the arm near the contacts.

NOTE

Check by use of a .002" gauge (smaller if avail-

able). Check with gauge between edges of the contacts to see that the gauge enters (or does not enter) equally on all sides.

(b) Speed-Adjusting-Wheel Friction Washer (Figure 81)

1. In order to check this adjustment, it is necessary that the speed adjusting spring be adjusted so that it requires a pull of 13 to 14 ozs. to separate the governor contacts. To measure, hook a 32 oz. scale over the contact spring next to the contact and pull parallel to the speed-adjusting spring. Adjust to the proper tension by means of the speed-adjusting wheel.

2. Insert a bank pin radially in the leather of the adjusting wheel, hook a 32 oz. scale over the pin at the periphery of the wheel and pull at right angle to the radius. It should require 16 to 24 ozs. to start the wheel moving. To adjust the friction, remove the friction washer and bend the large projections.

(c) Speed - Adjusting - Lever Stop Plate (Figure 82 for location of parts)

There should be .006" to .050" clearance between the speed-adjusting-lever wearing strip and the governor shell when the speed-adjusting-lever is held against the stop plate. To adjust, loosen the stop-plate mounting screws and position the plate. Tighten the screws.

(d) Governor Shims (Figure 82 for location of parts)

With the governor speed-adjusting lever in its unoperated position, there should be at least .006" clearance between the wearing strip and the adjusting wheel when the adjusting wheel is opposite the wearing strip and all the end thrust of the motor armature is taken up in a direction to make this clearance a minimum. Adjust by increasing or decreasing the number of shims on the armature shaft between the governor hub and the end frame casting of the motor.

(e) Speed Setting

1. When governed motors are used, a speed indicator (tuning fork) is required for the purpose of checking the motor speed. The fork is equipped with shutters attached to the ends of the tines. The governor is equipped with a target having white spots on a black background (Figure 82).

2. To check speed, the target should be well illuminated. Tap the speed indicator fork lightly to make it vibrate. Hold

the fork so that the shutters are close to the eye, and view the target through the openings in the shutters. If the motor is running at the correct speed, the target will appear stationary. If the motor is running too fast, the spots will appear to be moving in the direction of the motor rotation; if too slow in the opposite direction.

NOTE

There is a possibility of setting the speed incorrectly due to getting a speed multiple; i. e., the speed could be half the desired speed, or some multiple thereof, but the spots would appear to be stationary when viewed through the fork shutters. This fact should be kept in mind if trouble due to incorrect speed is experienced.

3. To adjust the speed, stop the motor and turn the governor adjusting wheel in one direction or the other a little at a time, checking the speed after each adjustment until the correct speed is obtained.

(4) The following four adjustments apply only to units with end-ring governors (Figure 82). Remove the governor guard, brush spring plate and remove governor cover.

(a) Inner and Outer Disk Contact Spring (Figure 83)

1. The distance from the inner surface of the governor cover to the highest point on the contact springs should be $25/32''$ to $27/32''$.

2. Place a "D" (89955) socket wrench over the nut located in the center of the governor cover. With a six-inch scale, measure the radial distance from the vertical surface of the wrench to the point where the scale touches the curved surface of the inner disk contact spring. This distance should be $17/32''$ to $19/32''$.

3. In a similar manner, measure the distance from the wrench to the point of contact on the outer disk contact spring. The distance should be $7/16''$ to $1/2''$.

4. To adjust for the above requirements, bend the inner and outer disk contact springs.

(b) Governor-Brush Spring-Plate Bracket (Figure 82)

1. A line established by the center of the outer disk and the center of one of the brushes should pass through some portion of the other brush.

2. The surface of the brush spring-plate bracket on which the brush spring plate is mounted should be in line with the outer surface of that part of the governor cover on which the target is mounted.

3. The brush spring-plate bracket should be parallel to the edge of the motor base plate.

4. To adjust for the above requirements, loosen the brush spring-plate bracket mounting screws and position the bracket. Tighten the screws.

(c) Governor-Brush Spring Pressure (Figure 82)

1. The carbon brushes should exert a pressure of $4-1/2$ to $5-1/2$ ozs. against their associated disks. To measure, apply an 8 oz. scale to the spring near the carbon brush and push (or pull) horizontally until the brush starts to move away from the disk.

2. Both carbon brushes should lie flat against their associated disks and the outer edges of the brushes should be flush with, or not more than $3/64''$ inside of, the outer edge of the disks.

3. To adjust for these requirements, remove the brush springs and bend them, if necessary. Reinstall springs and position them properly. Tighten the screws.

(d) Governor Guard (Figure 82)

There should be at least $1/16''$ clearance between the governor guard and the edge of the target. Adjust by bending the governor guard if necessary.

(5) The following two adjustments apply only to units with peripheral-ring governors (Figure 84).

(a) Governor-Brush Bracket (Figure 84A)

The governor brushes should be centrally located with respect to the governor collector rings, and the ends of the brushes should project $.015''$ to $.050''$ beyond the brush holder. To adjust, loosen the brush-holder bracket mounting screws and position the bracket. Tighten the screws.

(b) Governor-Brush Spring Tension (Figure 84A)

In order to check this requirement, it will be necessary to remove the brush

holder from its bracket. Apply the push end of an 8 oz. scale to the end of each brush and push in line with the brush. It should require 3 to 4 ozs. to depress each brush to within .015" to

.050" of the brush holder. After checking this requirement, replace the brush holder and recheck (a).

SECTION 3

LUBRICATION

1. GENERAL

1.01 Proper attention to lubrication is of the utmost importance.

1.02 Use Teletype KS-7470 oil at all locations where the use of oil is indicated. Use KS-7471 grease on all surfaces where grease is indicated, except the motor bearings. Apply two drops of KS-7470 oil to motor bearings every four months (depress oiler with metal object). If the motor is disassembled at any time, re-pack the bearings with KS-7471 grease.

1.03 All spring wicks and felt oilers should be saturated. The friction surfaces of all moving parts should be thoroughly lubricated. Over lubrication, however, which will permit oil or grease to drip or be thrown on other parts, should be avoided. Special care must be taken to prevent any oil or grease from getting between the armature and its magnet pole face or between electrical contacts.

1.04 Apply a thick film of grease to all gears.

1.05 Apply oil to all cams, including the camming surfaces of each clutch disk.

1.06 The following lubricants have been standardized for use on all types of Teletype apparatus. These lubricants supersede those referred to in preceding Teletype specifications. The lubricants can be ordered from Teletype as follows:

88970	1 Qt. of KS-7470 Oil
88971	1 Gal. of KS7470 Oil
88973	1 Lb. of KS-7471 Grease
88975	KS-8319 Grease Gun
97116	4-oz. Tube of KS-7471 Grease

The above grease is recommended instead of oil for lubricating motors equipped with ball bearings. The 88975 grease gun should be used for injecting grease into the bearings of Teletype ball bearing motors. The gun may be used also for applying grease to other parts of the apparatus and no other grease container need be carried. If this grease gun is not available, the oil listed in the foregoing should be substituted for lubricating ball bearing motors.

1.07 Instructions for Filling the Grease Gun

1. Unscrew the lubricant tube from the cap casting of the grease gun.

2. Insert fresh lubricant through the open end of the tube with the fingers. Apply gradually to eliminate air pockets.

3. Tamp the lubricant down solidly in the tube by pounding the closed end solidly against the palm of the hand. Continue to add lubricant until the tube is completely filled and the metal follower rests against the perforated tube cover.

4. Fill the cap casting with lubricant flush to the bottom side of the tube threads.

5. Screw the lubricant tube into the cap casting part way only. Then insert a pencil or rod through the perforated tube cover and exert pressure against the metal follower so as to expel any entrapped air past the tube threads. When lubricant begins to ooze through the threads, tighten the lubricant tube securely in the cap casting.

6. Operate the handle back and forth for several strokes or until lubricant is pumped from the nozzle. The gun is then ready for use. If the lubricant does not flow from the nozzle in a solid stream, it is an indication that all air has not been expelled from the lubricant tube. Invert the gun and pound the cap casting end against the palm of the hand to jar the lubricant into the pump cylinder.

1.08 Instructions for Lubricating Motor Ball Bearings.

The motor bearings are packed with grease before the motor leaves the factory and under ordinary operating conditions need no additional lubrication for approximately two months. At the regular lubricating intervals one or two strokes of the plunger of the gun should apply sufficient grease to each bearing. To lubricate, press the nozzle of the gun against the ball oiler and force the grease into the hole by pushing on the plunger of the gun. Care should be taken that the bearings are not overloaded. Overloading will result in the grease oozing out of the end castings and being forced into the motor or being thrown on other parts of the mechanism. After lubricating, the motor should be run for a few minutes and then any excess grease that has been forced out of the ends of the castings should be wiped off. Each time that the gun is used for lubricating a motor bearing, the plunger should first be depressed slightly to make sure that grease will be delivered.

1.09 Lubricate the following:

1. Clutch felt washers - saturate and apply coat of grease. See Note (C) on Page 2-1, also Note (H) for distributors.

2. Main shaft - bearings.

3. Operating lever - bearing (oil hole which runs between top of base casting and operating-lever bearing).

4. Tight - tape - stop or auto - stop-lever shaft - bearings. See Note (G) on Page 2-1.

5. Contact-lever bail - bearings.

6. Contact levers - bearings.

7. Feed Pawl - bearings.

8. Feed Lever - bearings.

9. Feed wheel - bearings.

10. Detent lever - bearings.

11. Detent roller - bearings

12. Retaining lid - bearings.

13. Stop cam - apply oil-grease-oil to periphery of cam. See Notes (C) and (G) on Page 2-1.

14. Stop arm - apply oil-grease-oil to bearings and also to end of arm at point of engagement with cam. See Notes (C) and (G) on Page 2-1.

15. Motor pinion - apply thin film of grease.

16. Main-shaft gear - apply thin film of grease.

17. Operating cam - apply thin film of grease to periphery of cam.

18. Springs - oil both loops of all helical springs that exert a nominal tension of less than 2-1/2 pounds. Apply grease to both loops of all helical springs that exert a nominal tension of 2-1/2 pounds or more.

19. Operating-lever adjusting screw - apply thin film of grease to head of screws.

20. Governor spark-protection contact assembly (86960 on units with a. c. governed motors) - apply thin film of grease to engaging surface of bakelite buffer. See Note (G) on Page 2-1.

21. Bell-on-blank contact operating lever - bearing. See Note (G) on Page 2-1.

22. End-of-tape stop contact pin - at guide bracket (oil sparingly).

23. Motor bearing lubrication holes - two - grease - use grease gun.

24. Bakelite buffer on the long contact spring - apply grease to the engaging surface on units so equipped. See Note (G) on Page 2-1.

ITEMS (25) THRU (32) APPLY TO UNITS EQUIPPED WITH AN ALL STEEL CLUTCH

25. Clutch-internal mechanism - 4 drops.

26. Latch lever - apply oil-grease-oil to bearings.

27. Stop lever - apply oil-grease-oil to bearings and to end of lever at point of engagement with shoe release lever, also to camming surface.

28. Clutch drum bearing - felt oiler - saturate. See Note (G) on Page 2-1.

29. Clutch disk - apply thin film of grease to periphery - See Note (G) on Page 2-1.

30. End of armature lever and armature bearing - grease - oil.

31. Entire length of armature retractive spring - grease. See Note (G) on Page 2-1.

32. Reset cam apply thin film of grease. See Note (F) on Page 2-1.

ITEMS (33) THRU (38) - SEE NOTES (F) AND (H) ON PAGE 2-1

33. Stop lever felts - saturate with oil and apply coating of grease. See Note (C) on Page 2-1.

34. End of stop lever - oil, grease, oil.

35. Stop cam lug - latching and camming surfaces - oil, grease, oil.

36. End of armature lever - grease.

37. Latching steps of stop lever - grease.

38. Reset extension - oil, grease, oil.

ITEMS (39) THRU (44) - SEE NOTE (I) ON PAGE 2-1.

39. Point where transmitter operating

lever makes contact with the transfer contact swinger insulator - apply thin film of grease.

40. Point where lock pawl makes contact with the line shorting contact insulator or between the insulators - apply thin film of grease.

41. Send-Stop Lever - pivot point, two spring posts, and operating lobe, one drop of oil.

42. Lock Pawl - blocking surface and pivot point - two drops of oil.

43. Switch Lever - pivot point and point of engagement with the switch knob - one drop of oil.

44. Switch Lever Spring - one drop of oil on both ends.

THE FOLLOWING ITEMS APPLY TO THE BREAK-LOCK MECHANISM - SEE NOTE (G) ON PAGE 2-1.

1. Armature lever pivot points - oil.
2. Contact lever pivot points - oil.
3. Contact pawl at intersection with armature lever and with its guide and mounting plate bracket - oil.
4. Cam - grease.
5. Push rod at bearing points - oil.

In lubricating the mechanism care should be taken to see that oil does not lodge between the core faces and the armature or between contact points.

THE FOLLOWING ITEMS APPLY TO THE RUBOUT DELETER MECHANISM

1. Oiler washer located on the upper cam of the cam assembly - saturate with oil.
2. Oiler washer assembled to the cam follower of the control assembly - saturate with oil.
3. Lever assembly - at pivot roller.
4. Link - at pivot and slot.
5. Intermediate lever - at pivot.
6. Rubout bail - at pivots.
7. Operating cam and the larger cam of the cam assembly - apply thin film of grease to the periphery of both cams.

THE FOLLOWING ITEMS APPLY TO THE TORN FEED HOLE TAPE STOP MECHANISM

1. Feed roll shaft (both ends).

2. Feed roll ratchet (thin film of grease).

3. Feed roll gear (thin film of grease).

4. Detent lever.

5. Detent roller.

6. Idler gear shaft (both sides of gear and at the end of shaft).

7. Feed wheel (both sides)

8. Feed wheel spring clutch.

9. Feed wheel.

10. Feed wheel shaft (both ends of block).

11. Reset wheel (both sides).

12. Reset wheel spring clutch.

13. Contact operating arm cam and gear (thin film of grease).

14. Contact operating arm shaft (both sides of block).

15. Retaining lid (each end).

16. Retaining lid latch.

THE FOLLOWING ITEMS APPLY TO SINGLE STEP TAPE FEED SUPPRESSION MECHANISM - SEE NOTE (F) ON PAGE 2-1

1. Upper edge of restoring blade - grease.
2. Stepped end of restoring lever - grease.
3. Step on non-repeat lever - grease.
4. Step on trip-off lever - grease.
5. Trip-off latch projection which extends between the non-repeat lever and the trip-off lever - grease.
6. Tooth of feed latch lever - grease.
7. Contact surface of tape feed pawl extension - grease.

THE FOLLOWING ITEMS APPLY TO CONTROL SWITCH - SEE NOTE (N) ON PAGE 2-1

1. Control contact switch detent lever - at roller and bearing.
2. Control contact switch detent cam - apply grease to cam surfaces.



FIGURE 1

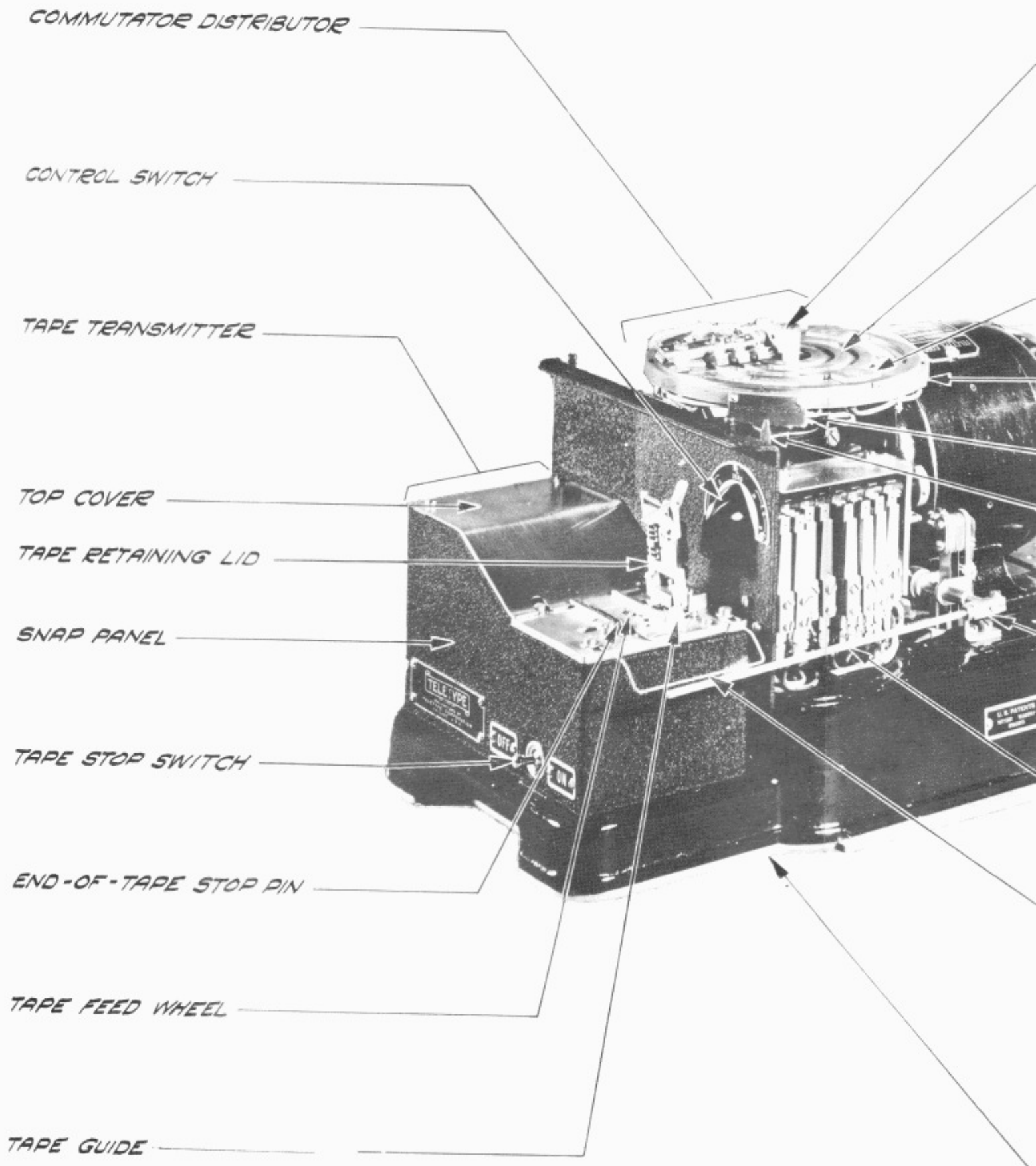

FIGURE 1A

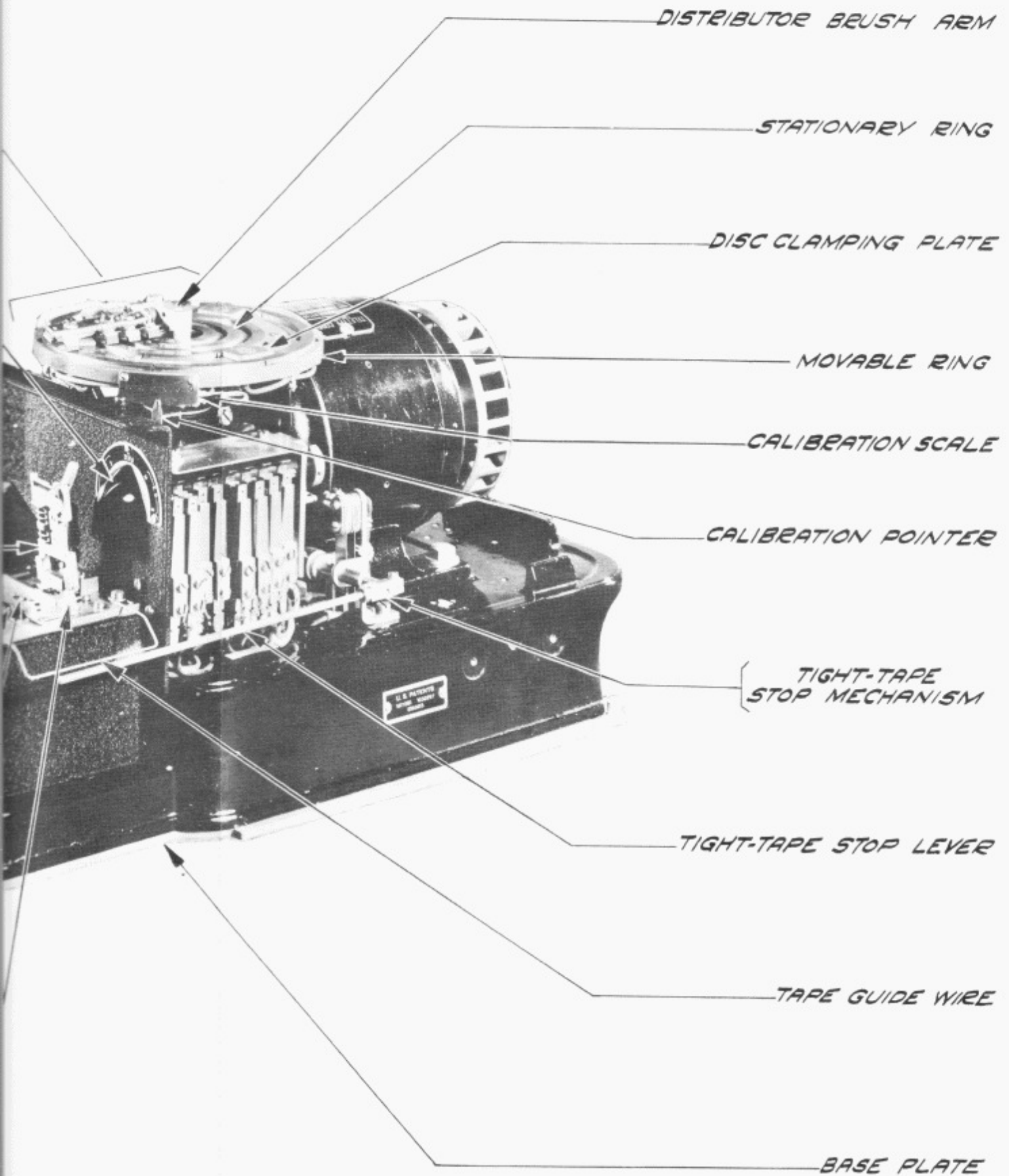

FIGURE 1A

DISTRIBUTOR BRUSH ARM

DISTRIBUTOR BRUSH

SEND-STOP LEVER

TRANSMISSION CONTROL RELAY

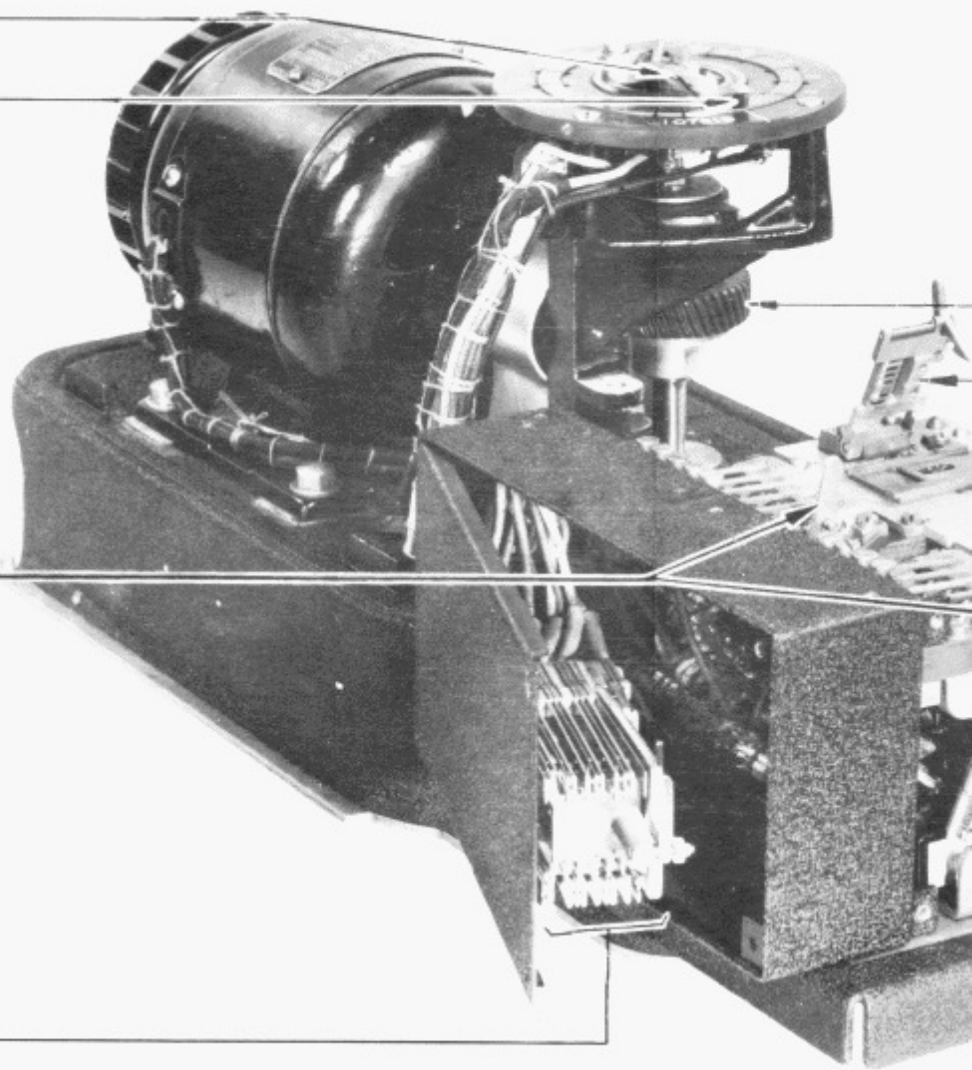

FIGURE 2

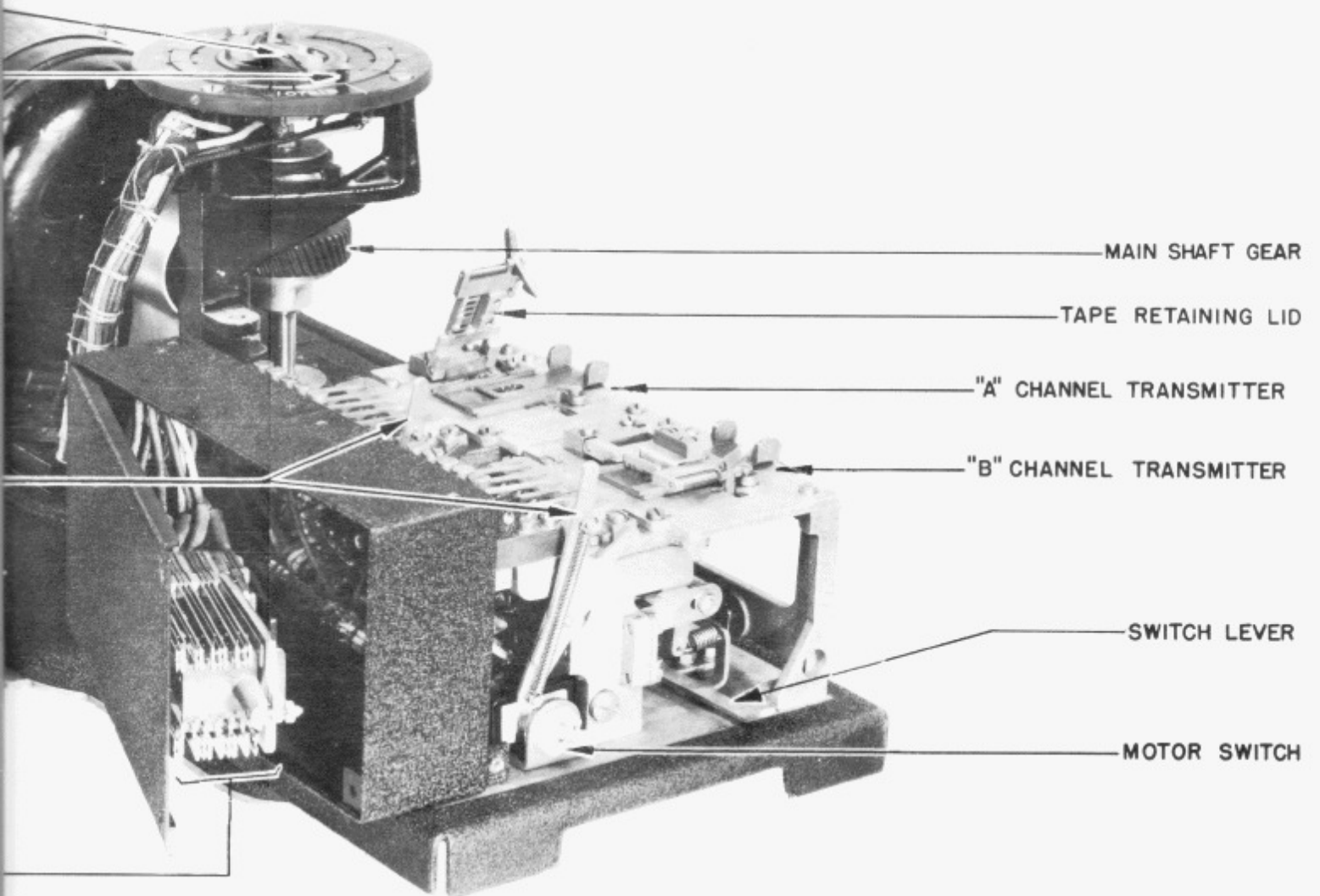

FIGURE 2

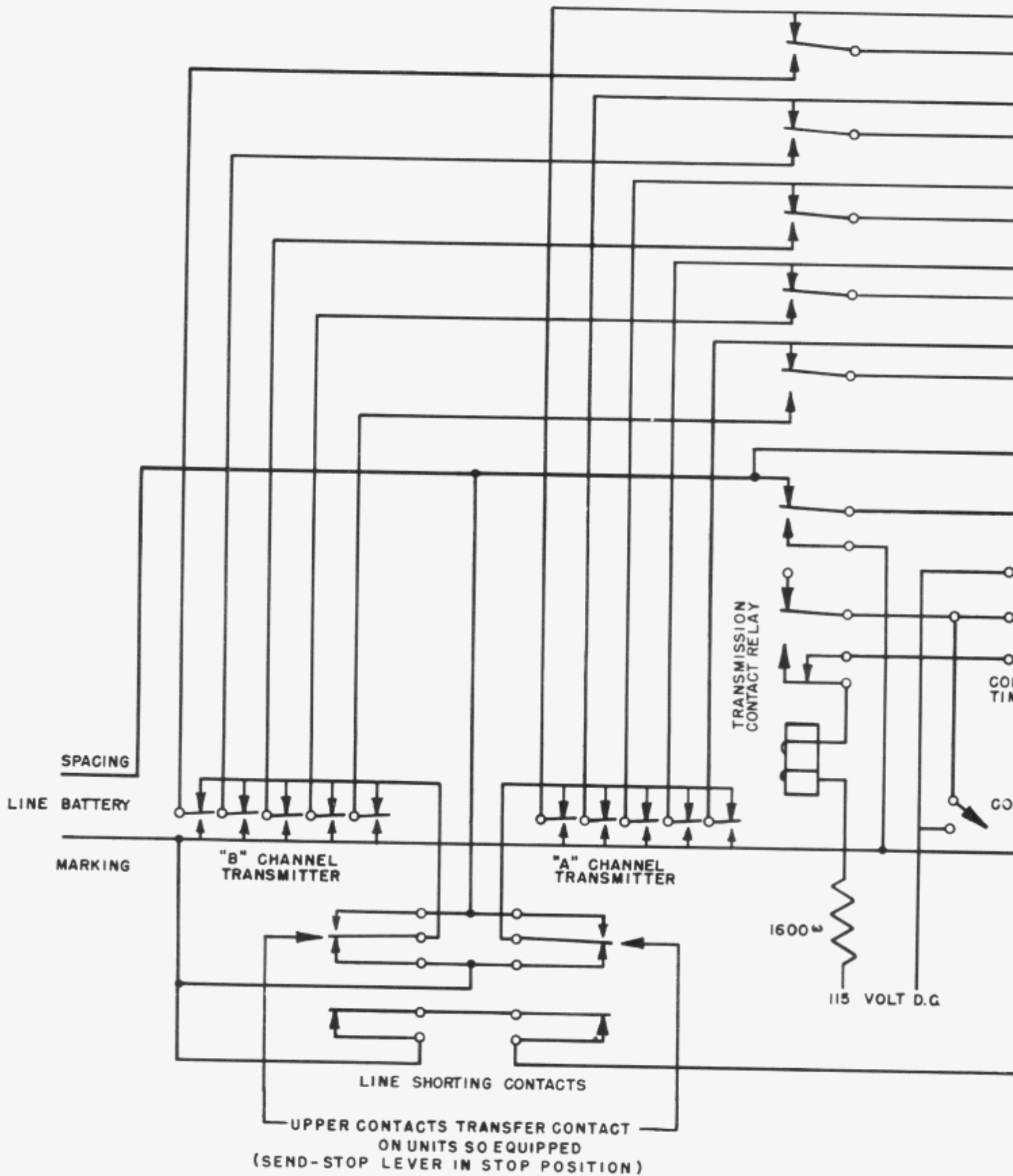

FIGURE 3

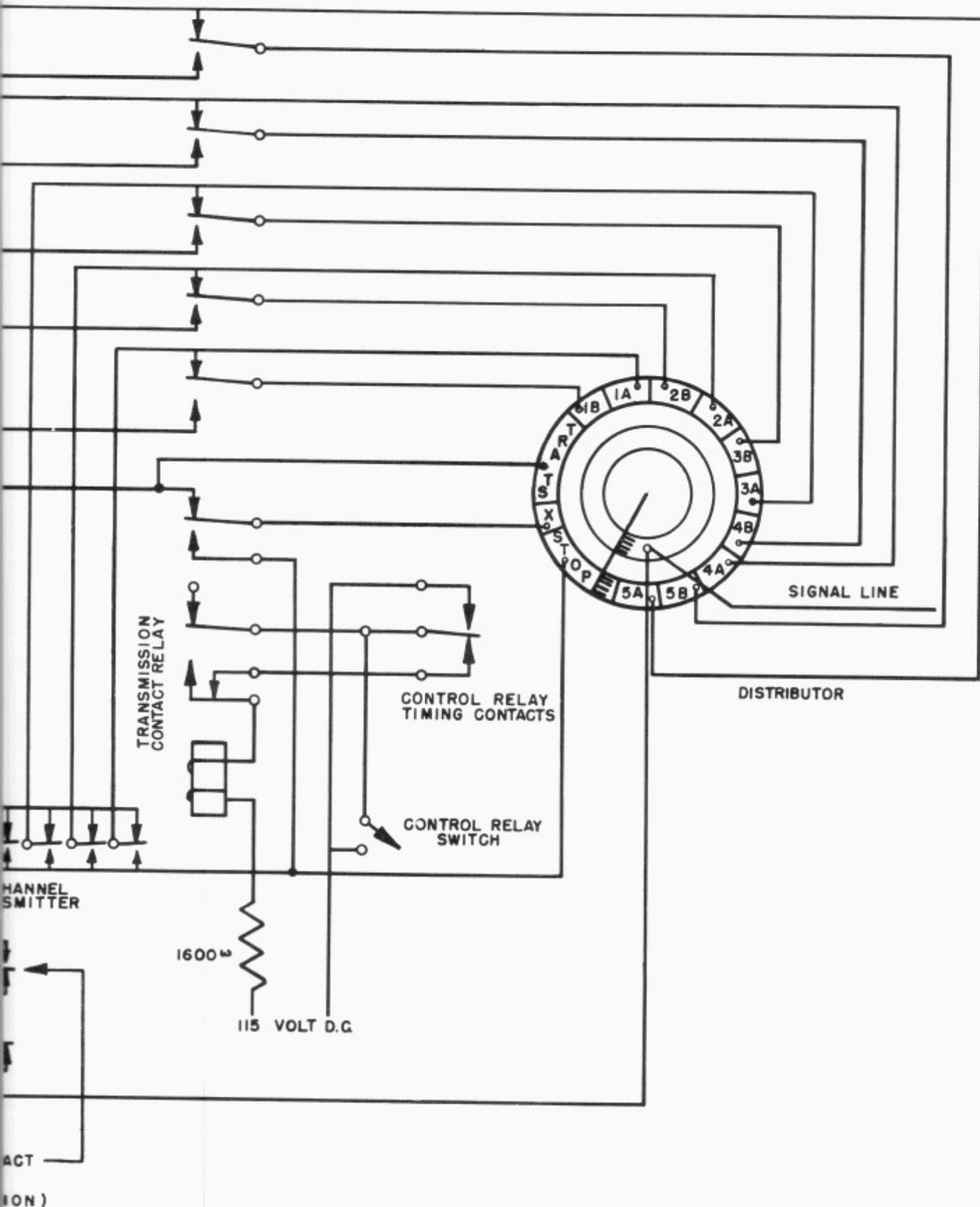

FIGURE 3

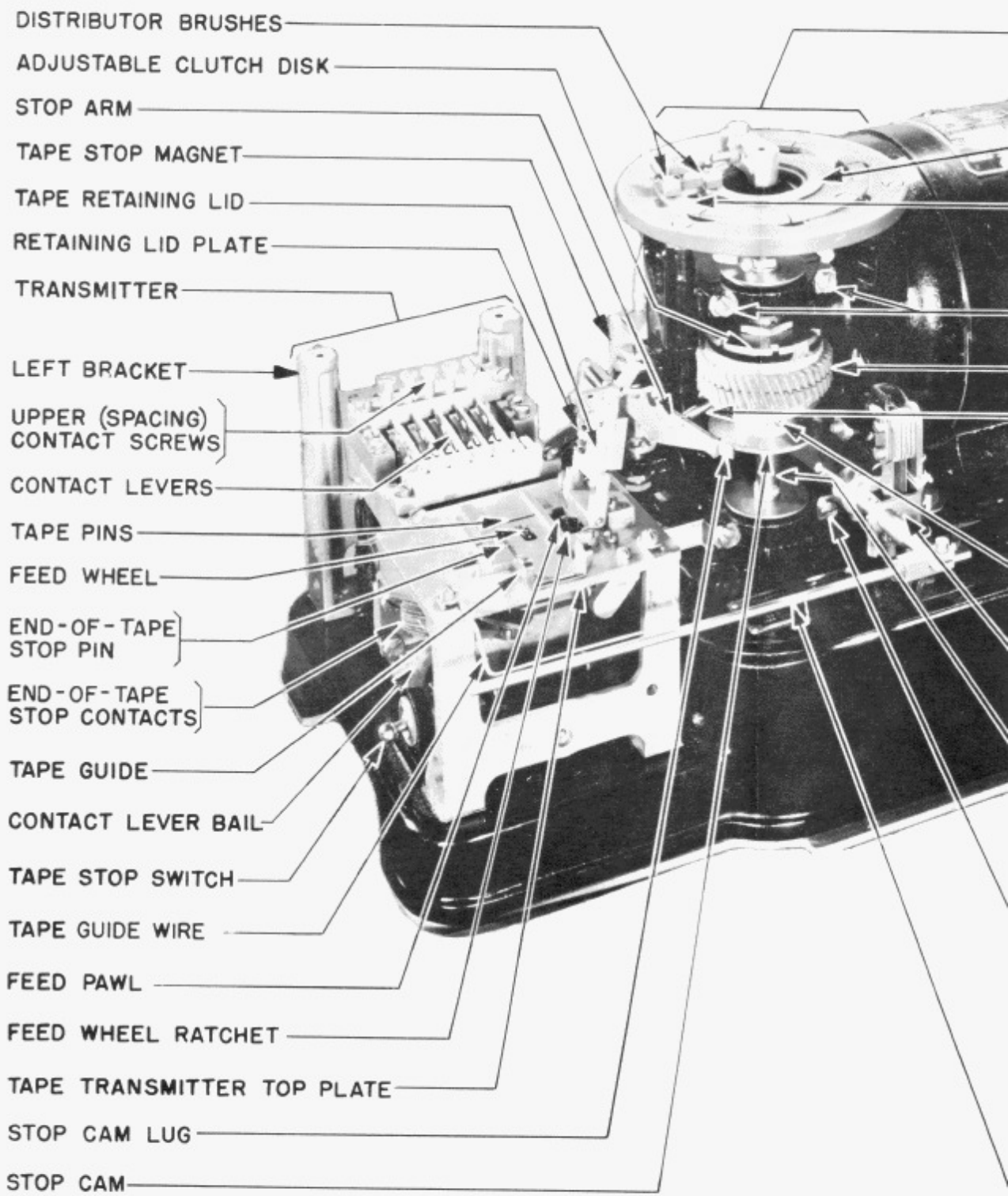

FIGURE 4

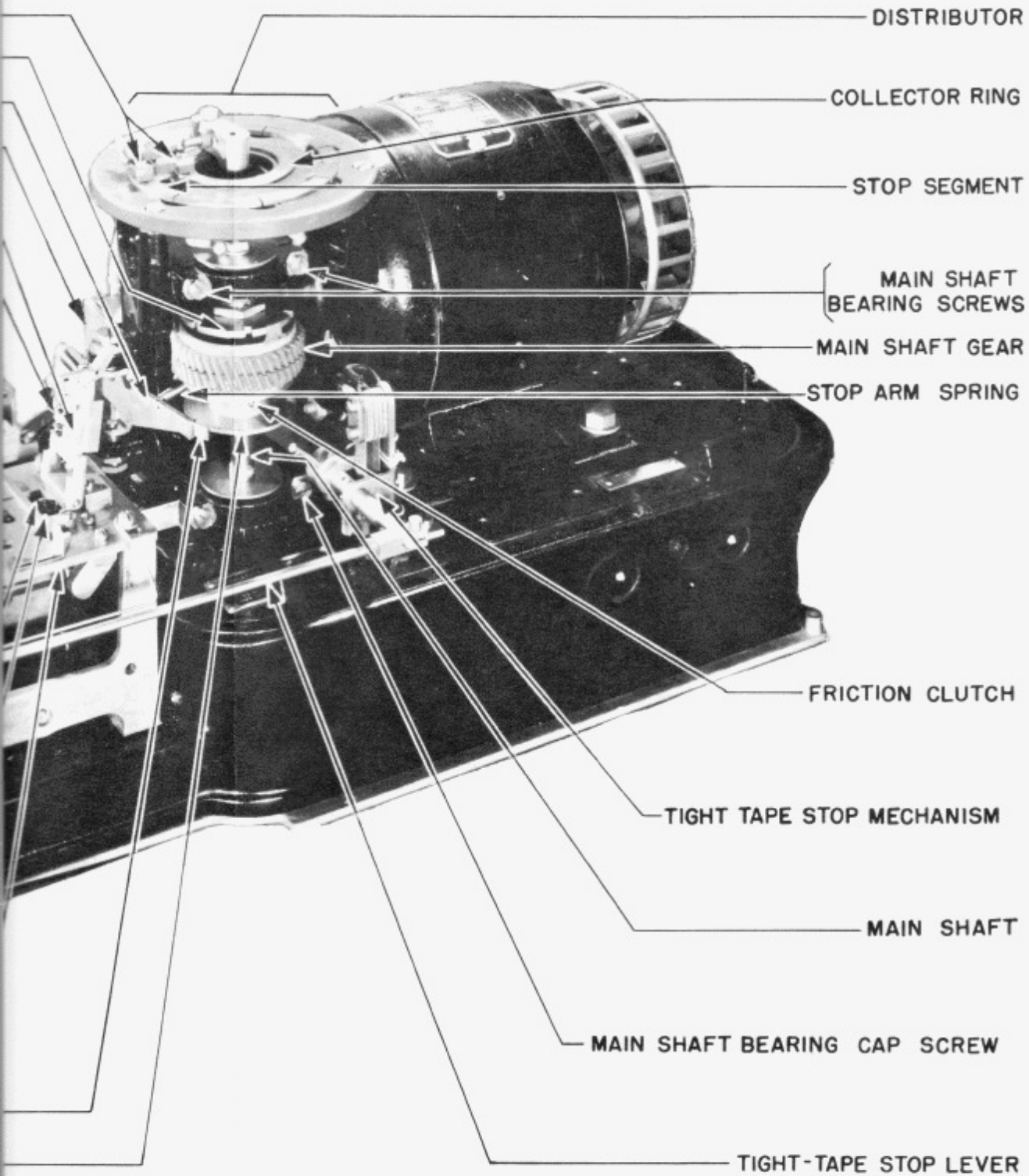

FIGURE 4

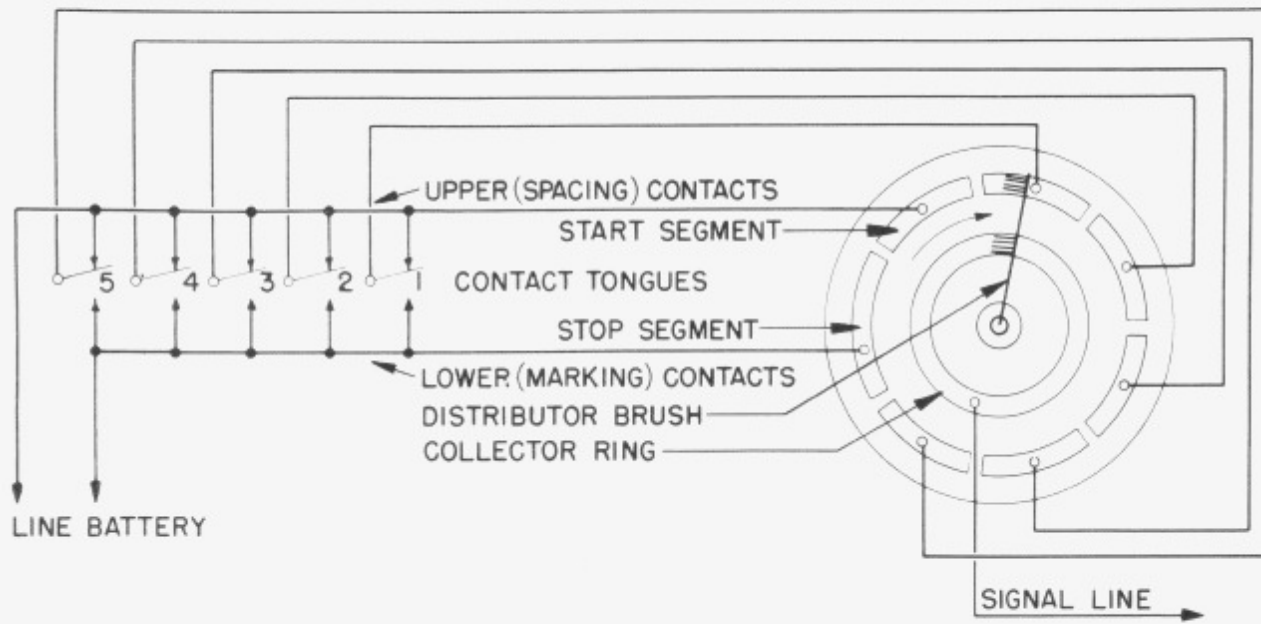

FIGURE 5

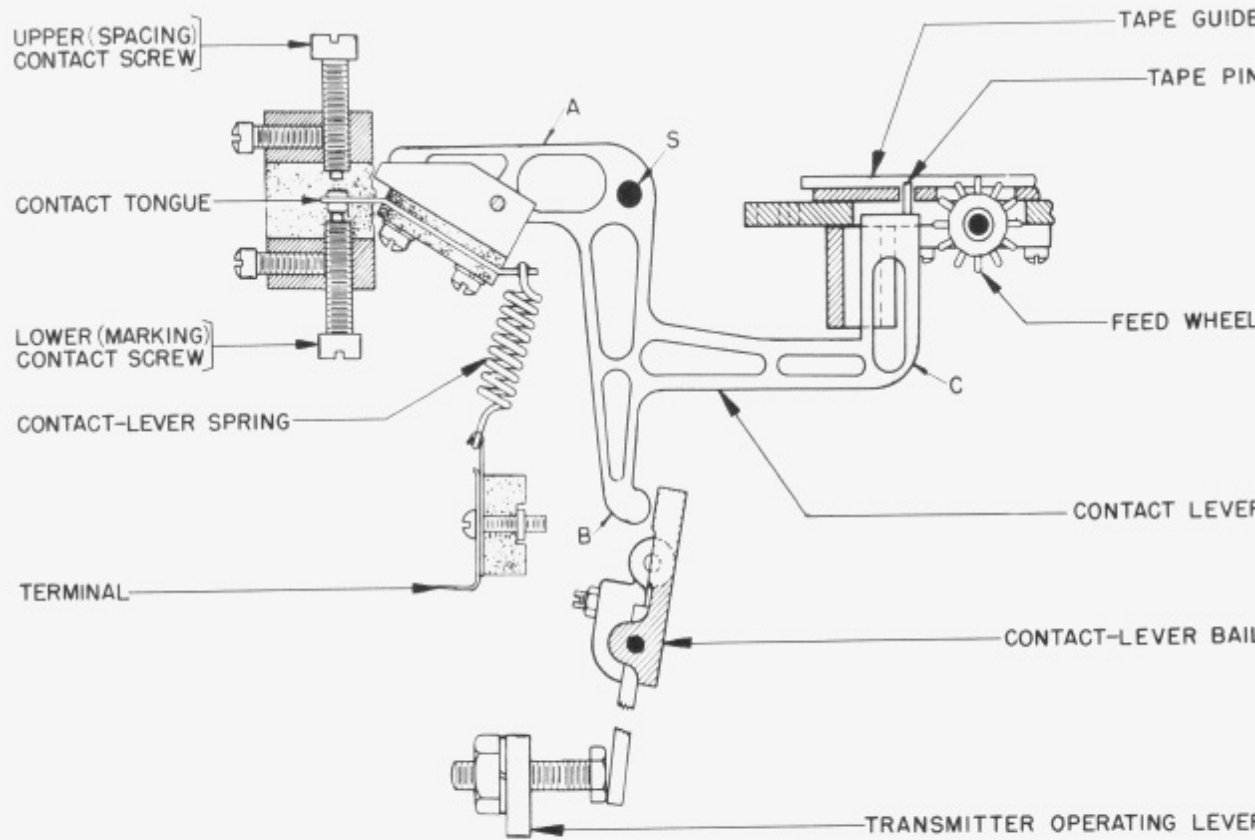

FIGURE 6

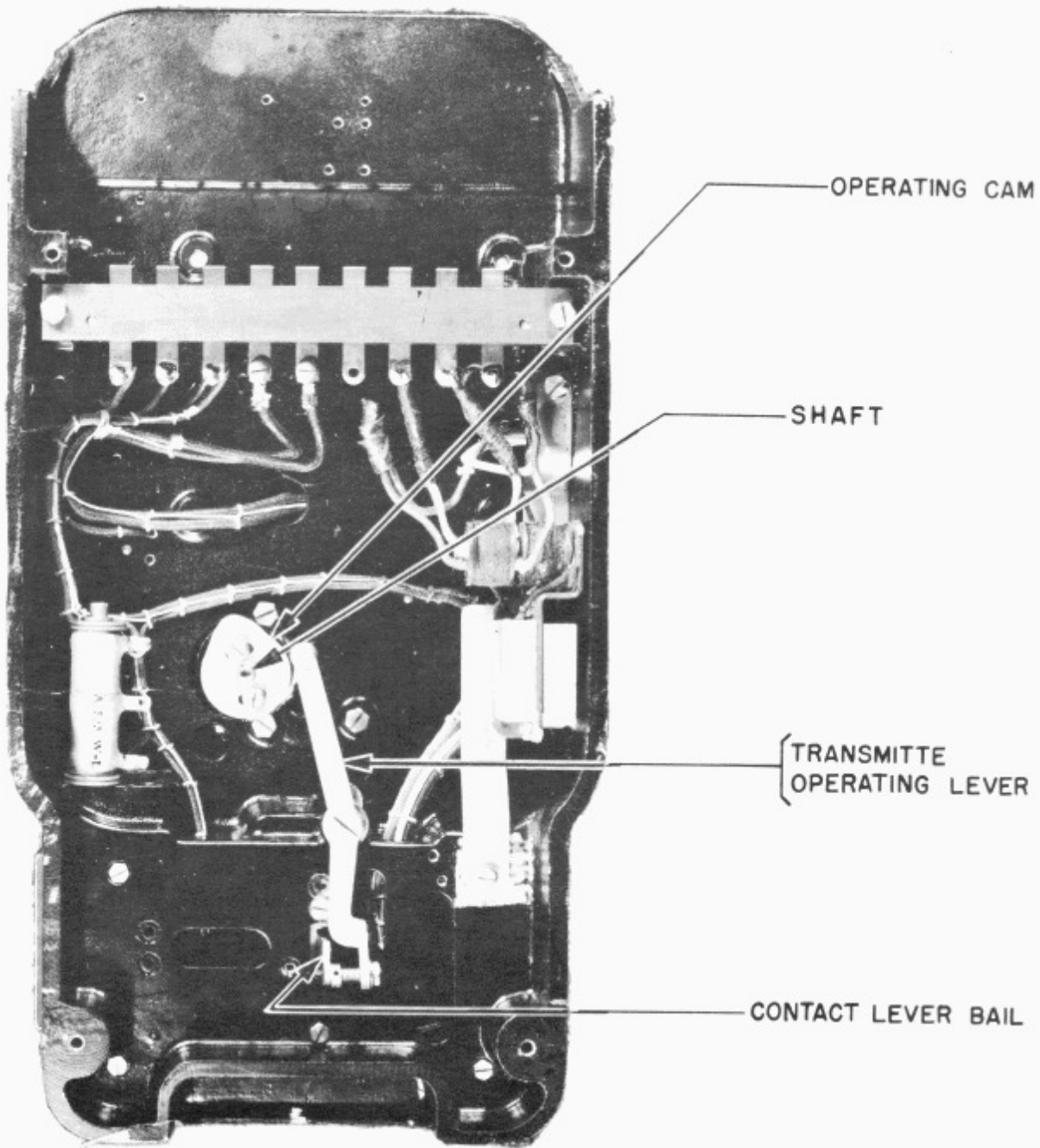

FIGURE 7

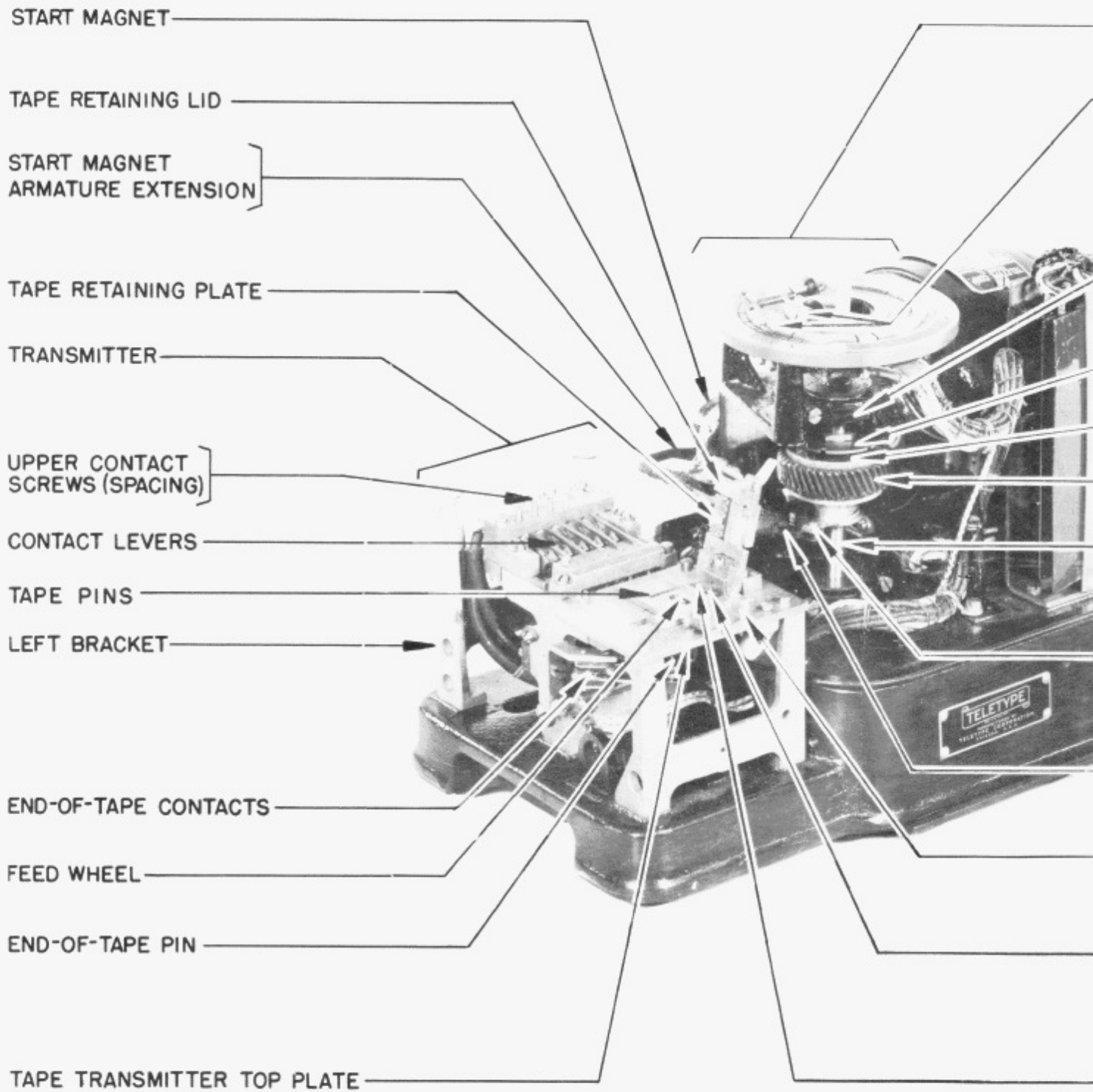

FIGURE 8

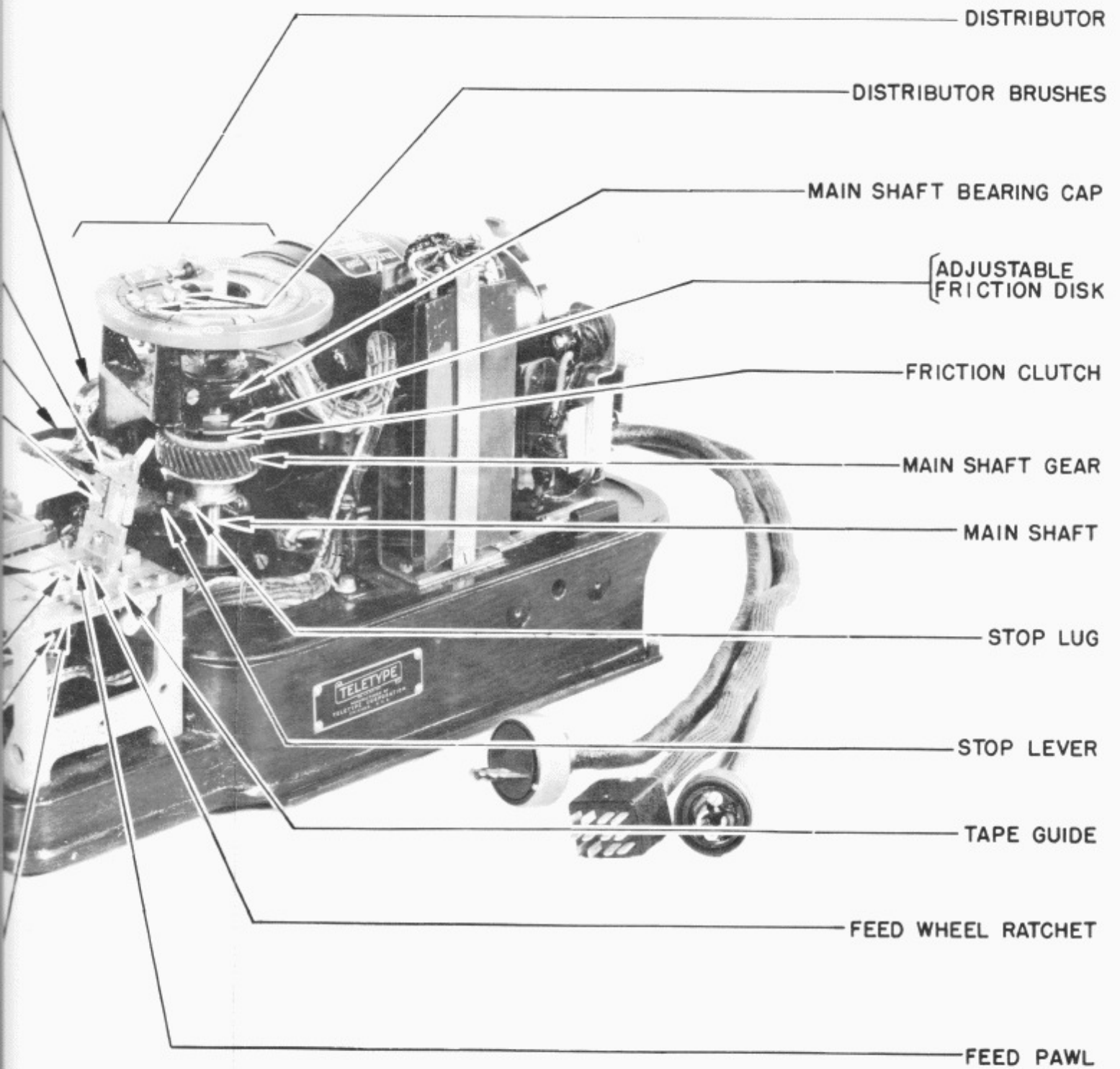

FIGURE 8

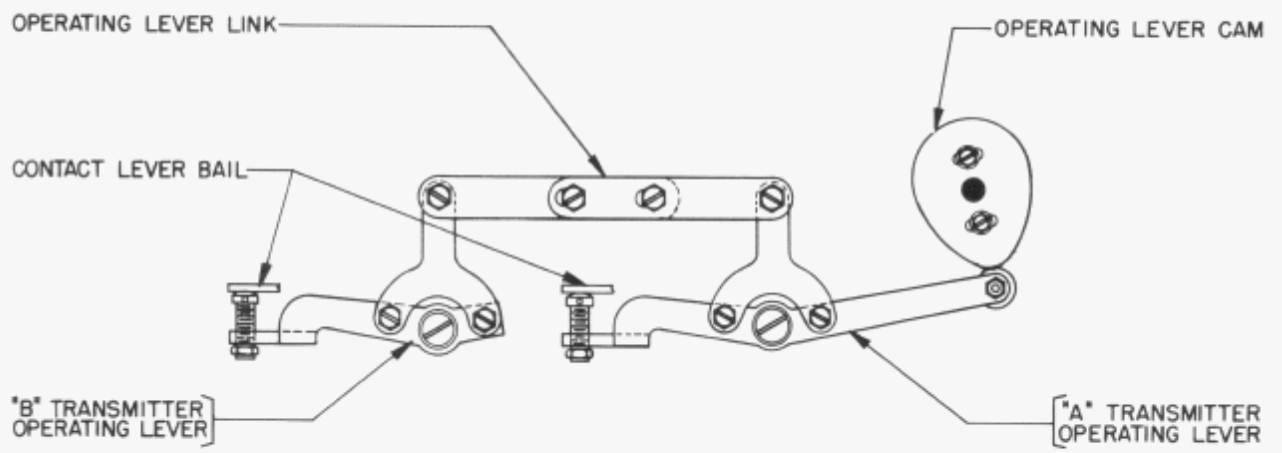

FIGURE 9

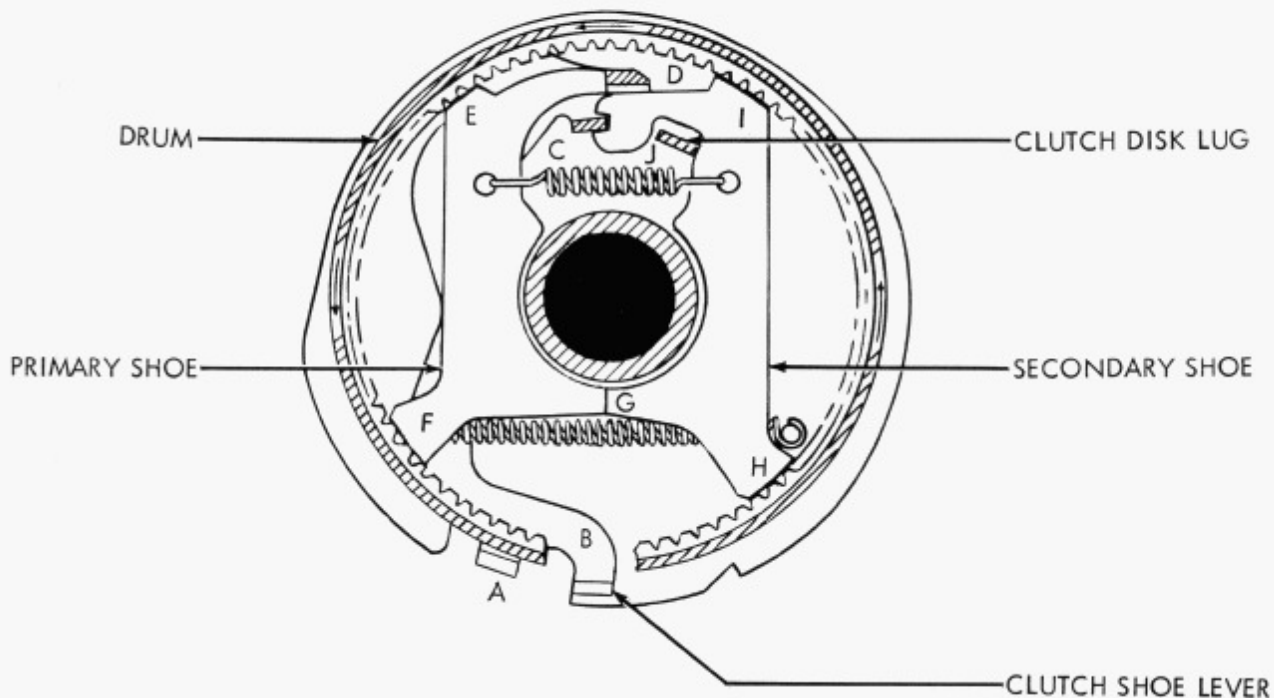

Figure 2-10A Clutch - Engaged

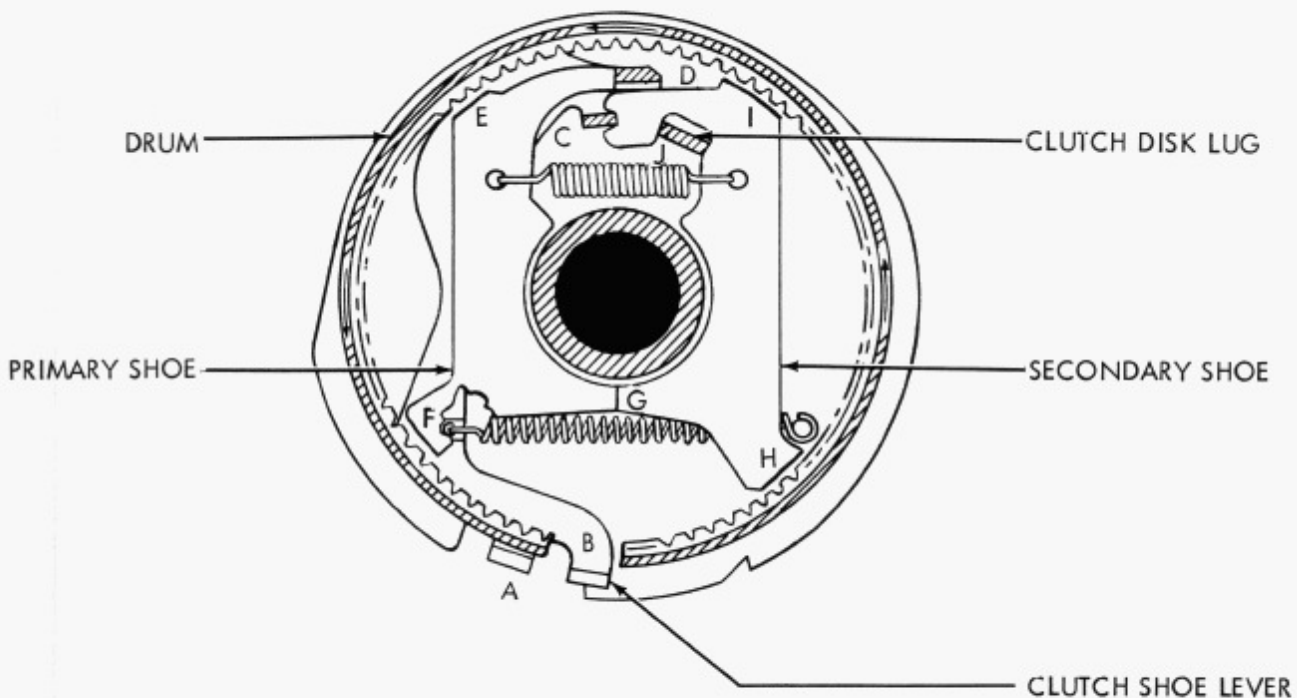

Figure 2-10B Clutch - Disengaged

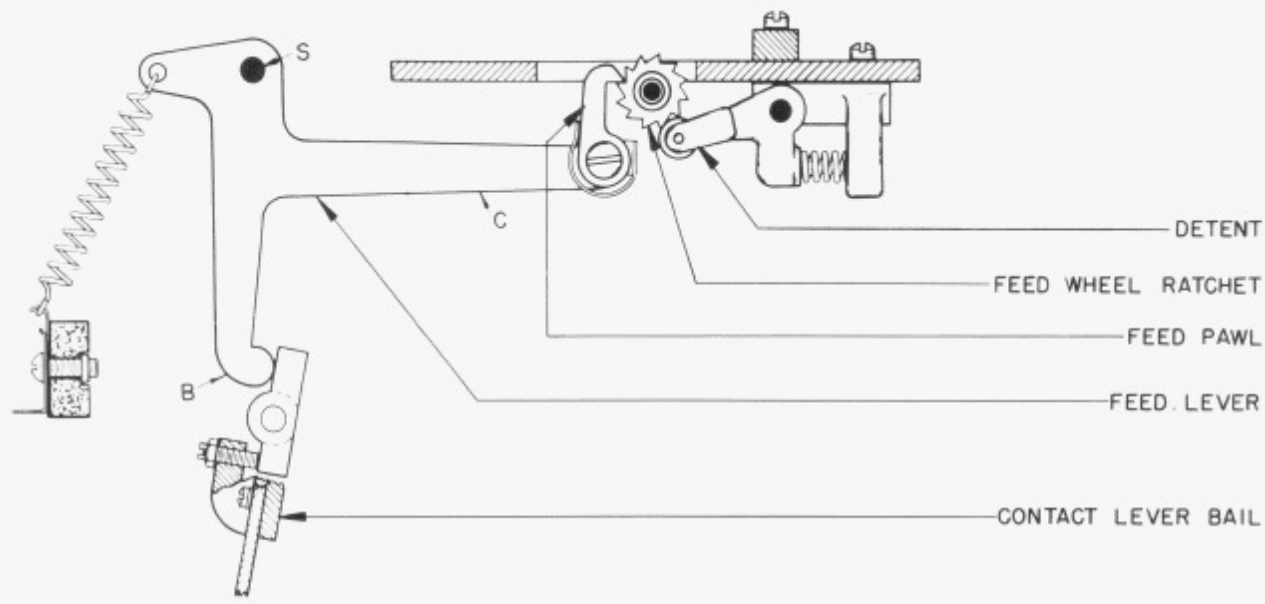

FIGURE 11

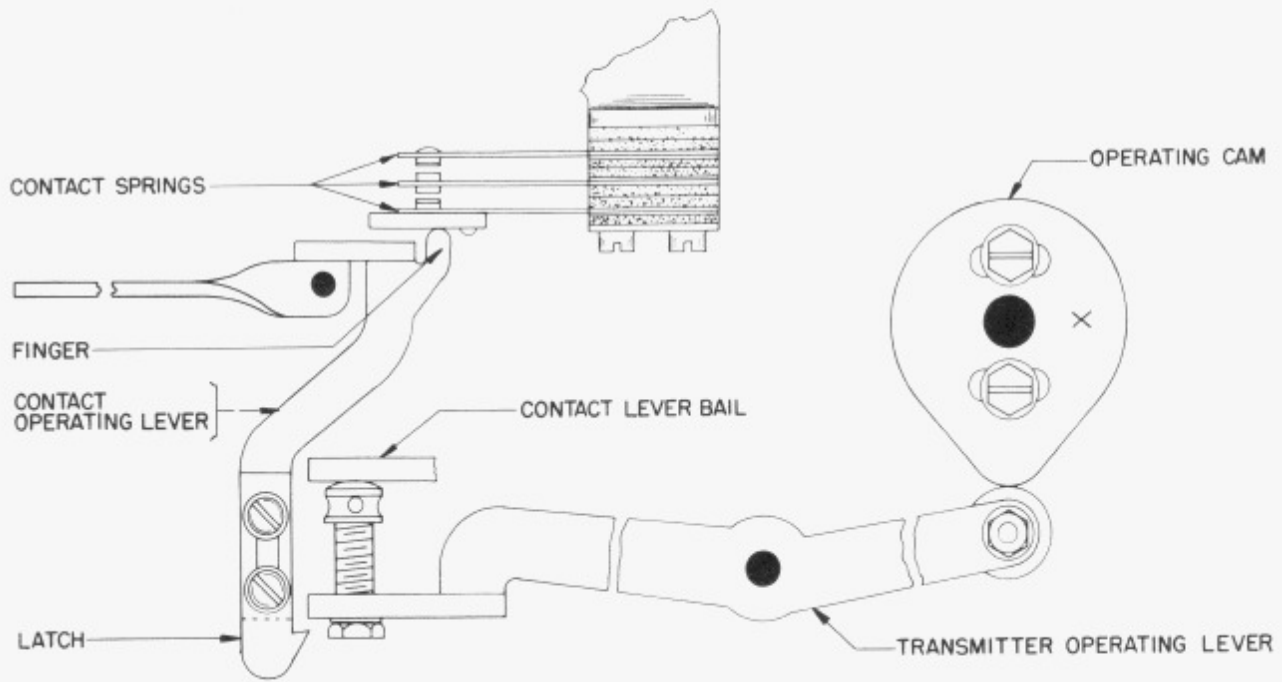

FIGURE 12

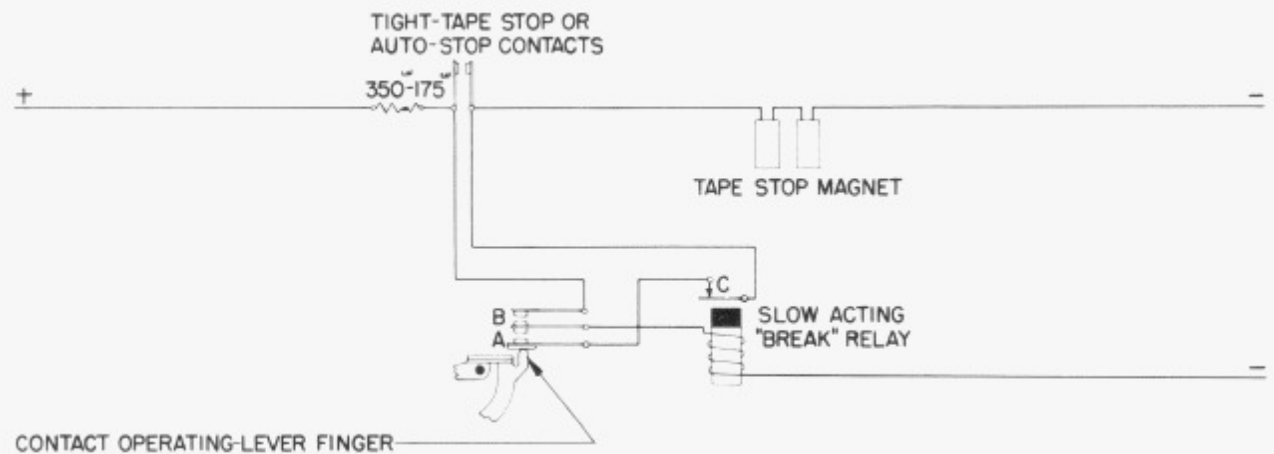

FIGURE 13

DETENT
 WHEEL RATCHET
 FEED PAWL
 FEED LEVER
 CONTACT LEVER BAIL

141B

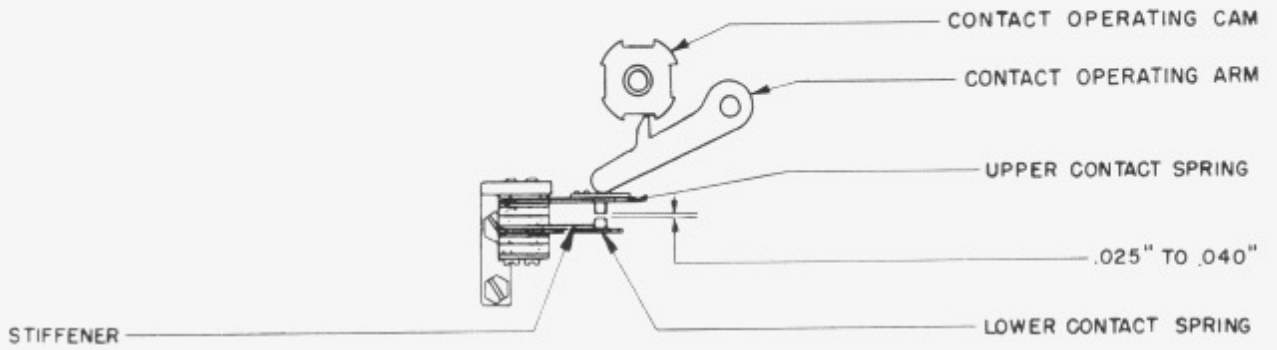

FIGURE 14

OPERATING CAM

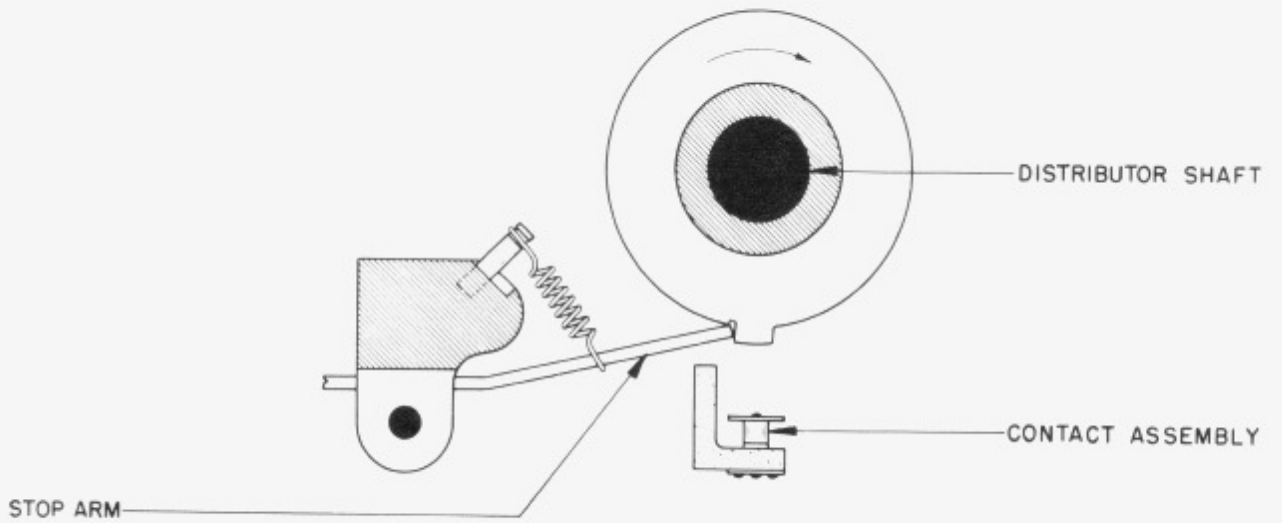
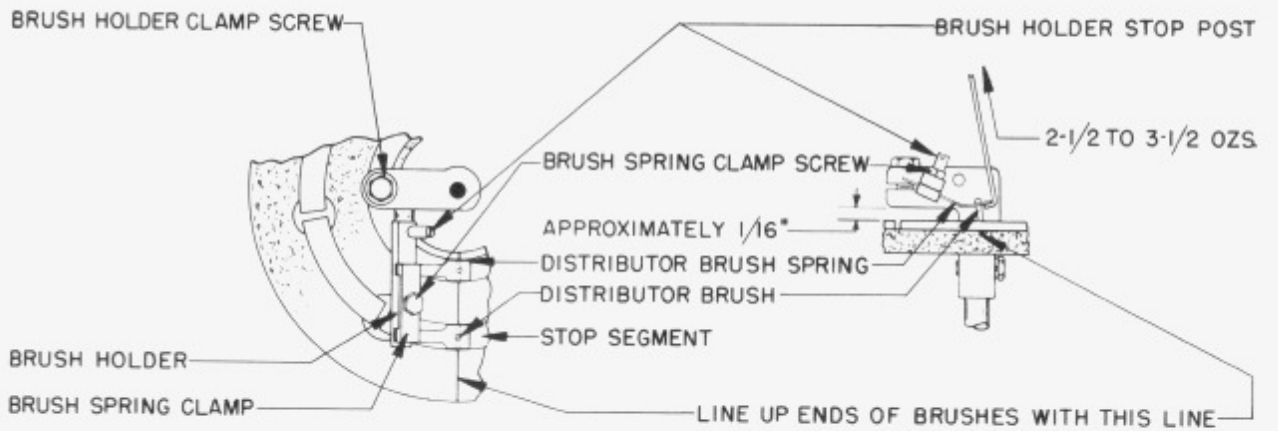

FIGURE 15

R OPERATING LEVER



(A)

(B)

FIGURE 16

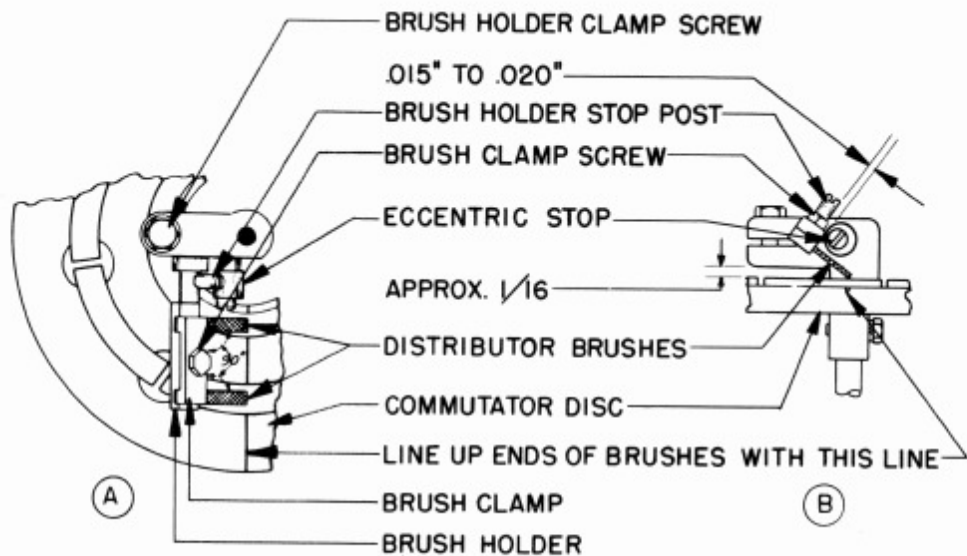

FIGURE 17

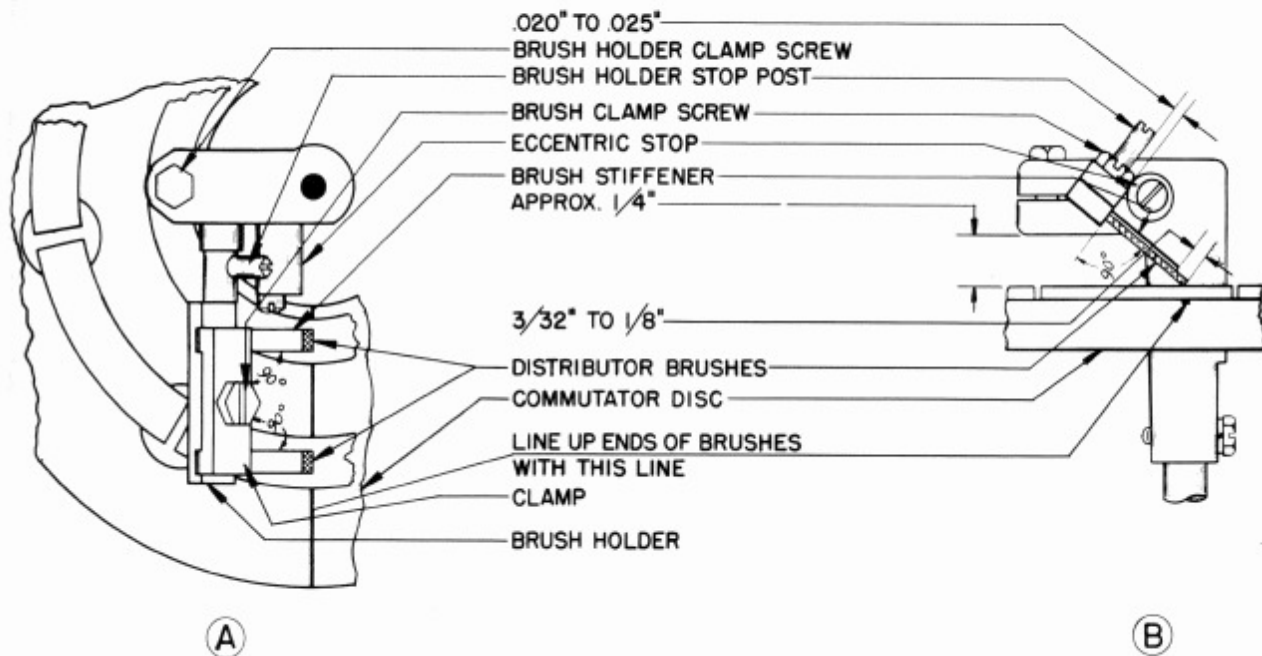

FIGURE 18

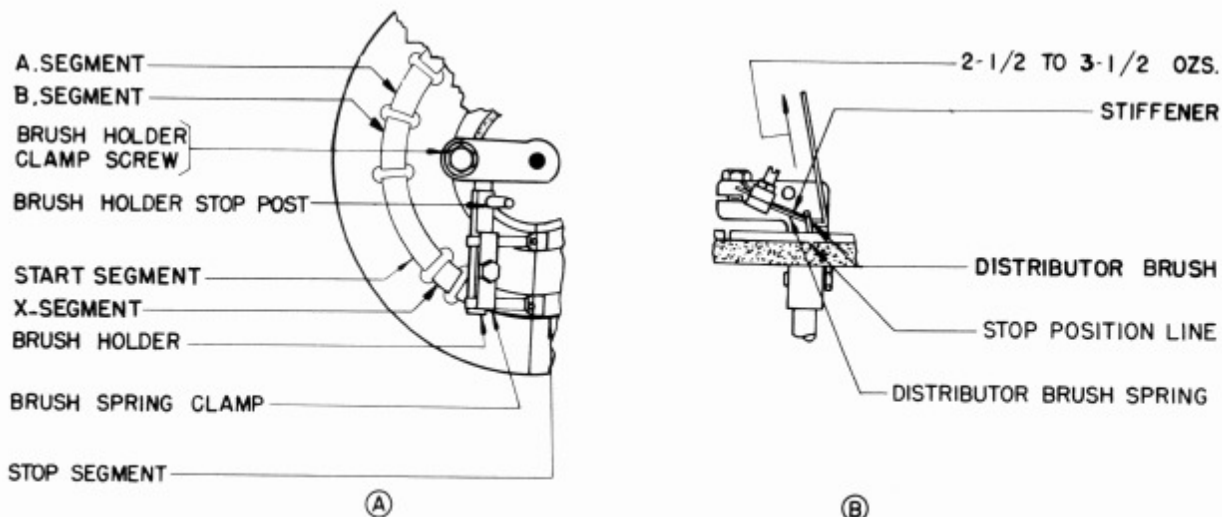

FIGURE 19

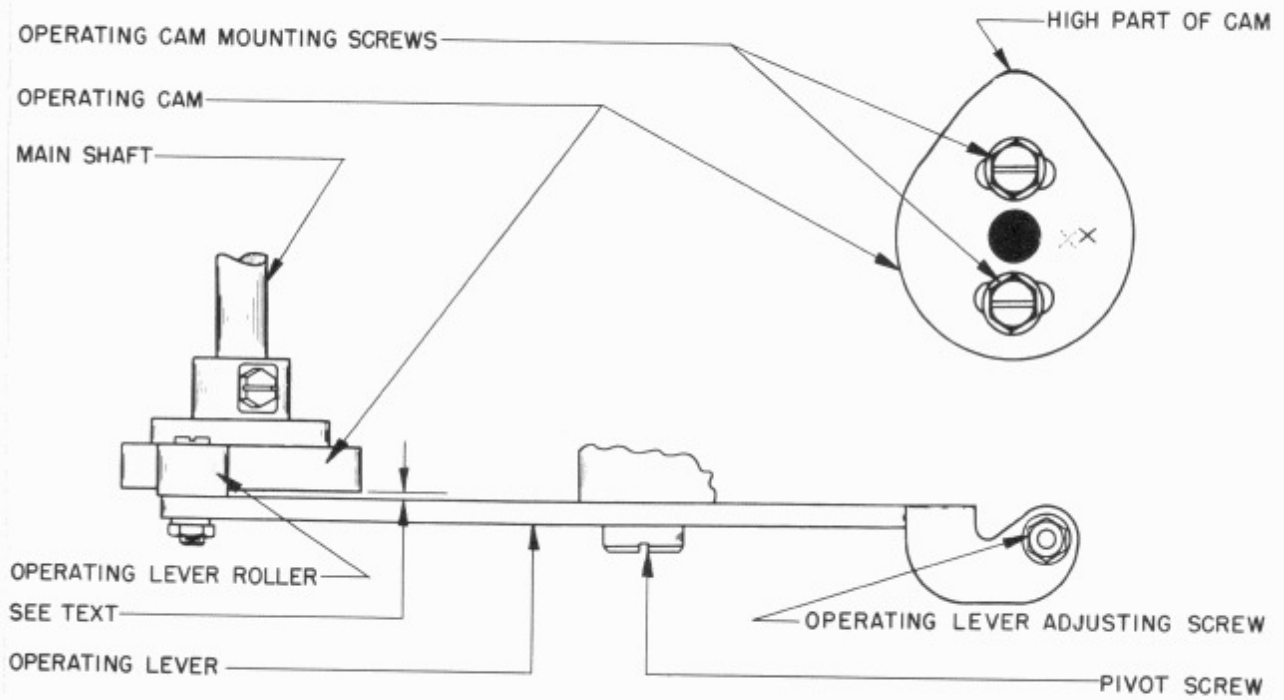

FIGURE 20

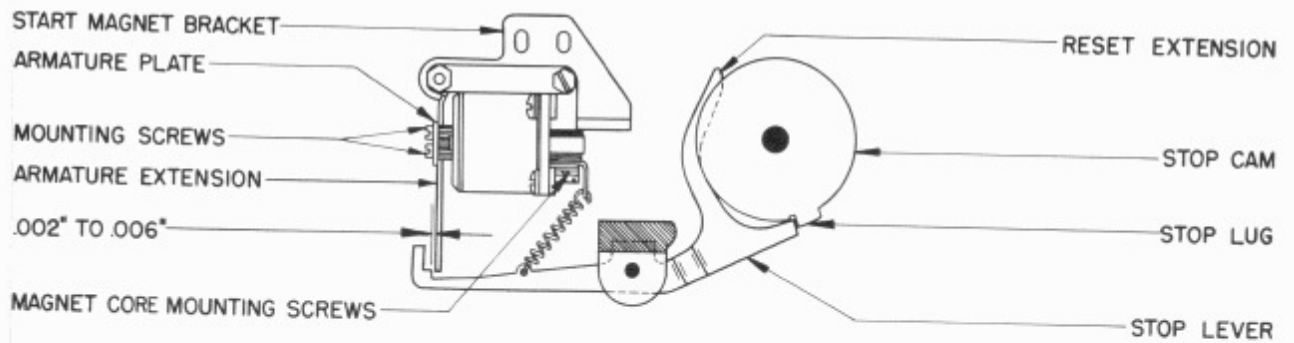

FIGURE 21



FIGURE 22

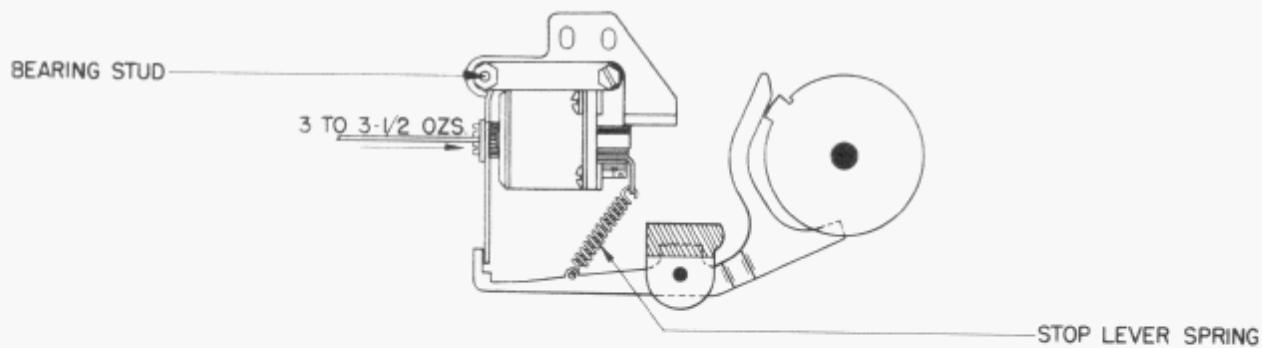

FIGURE 23

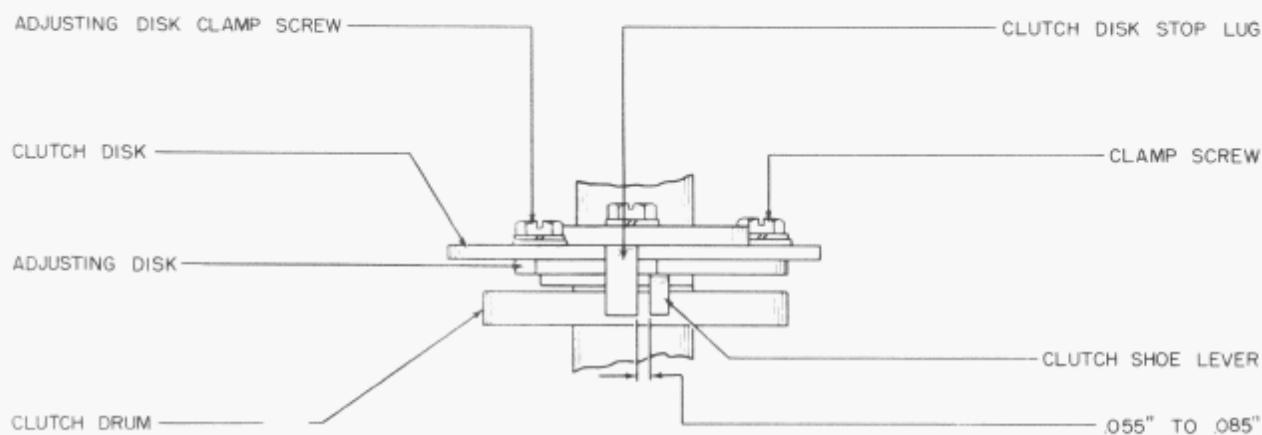

FIGURE 24

141B

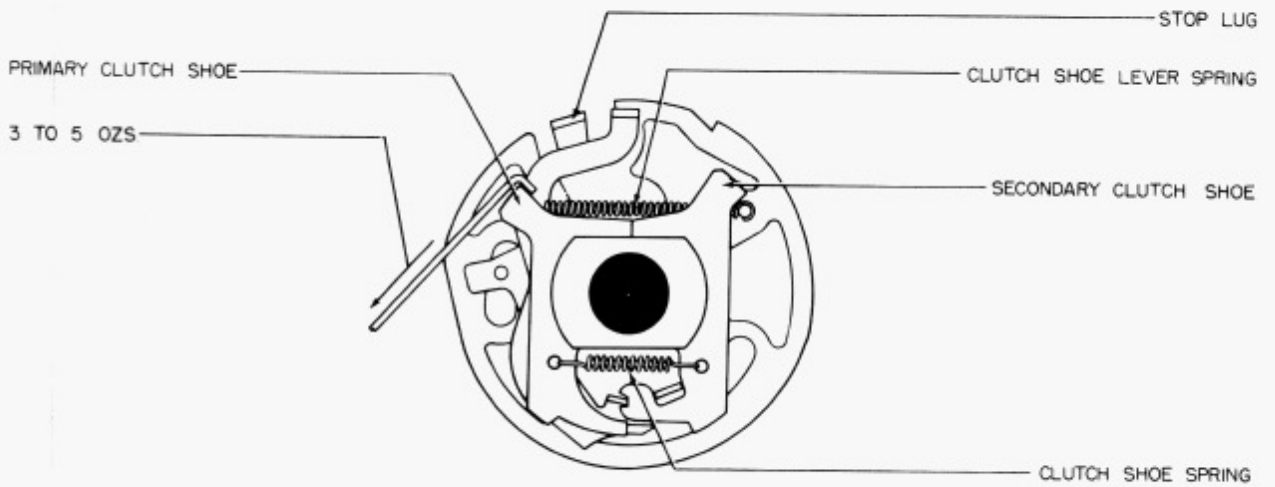
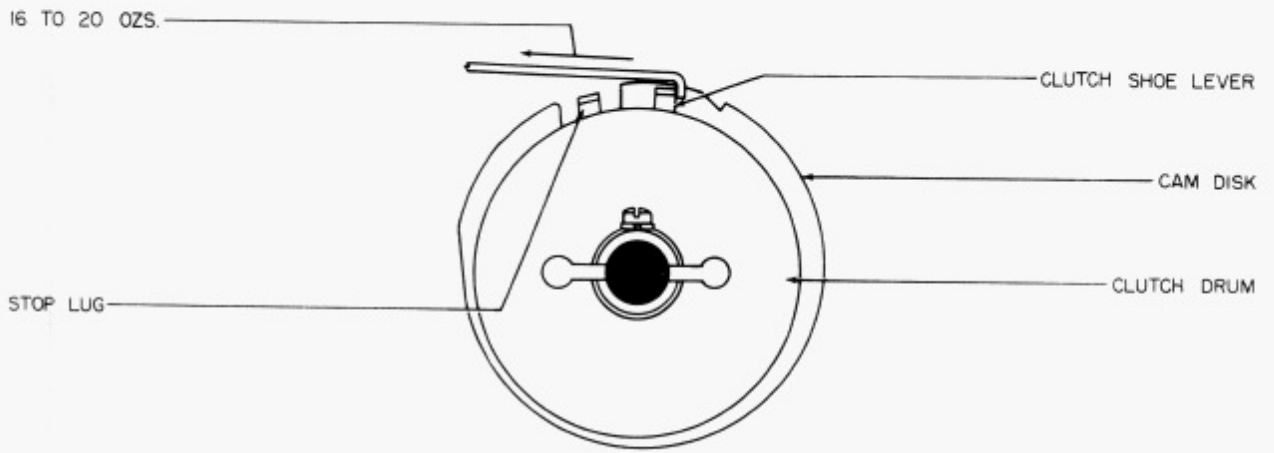

FIGURE 25

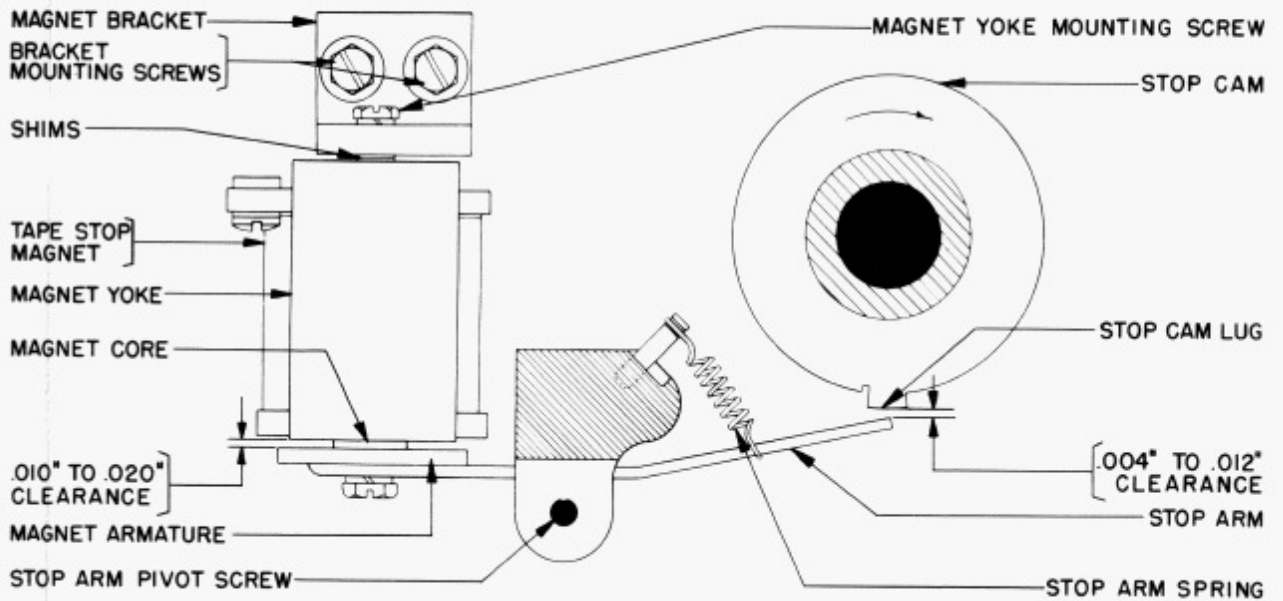

FIGURE 26

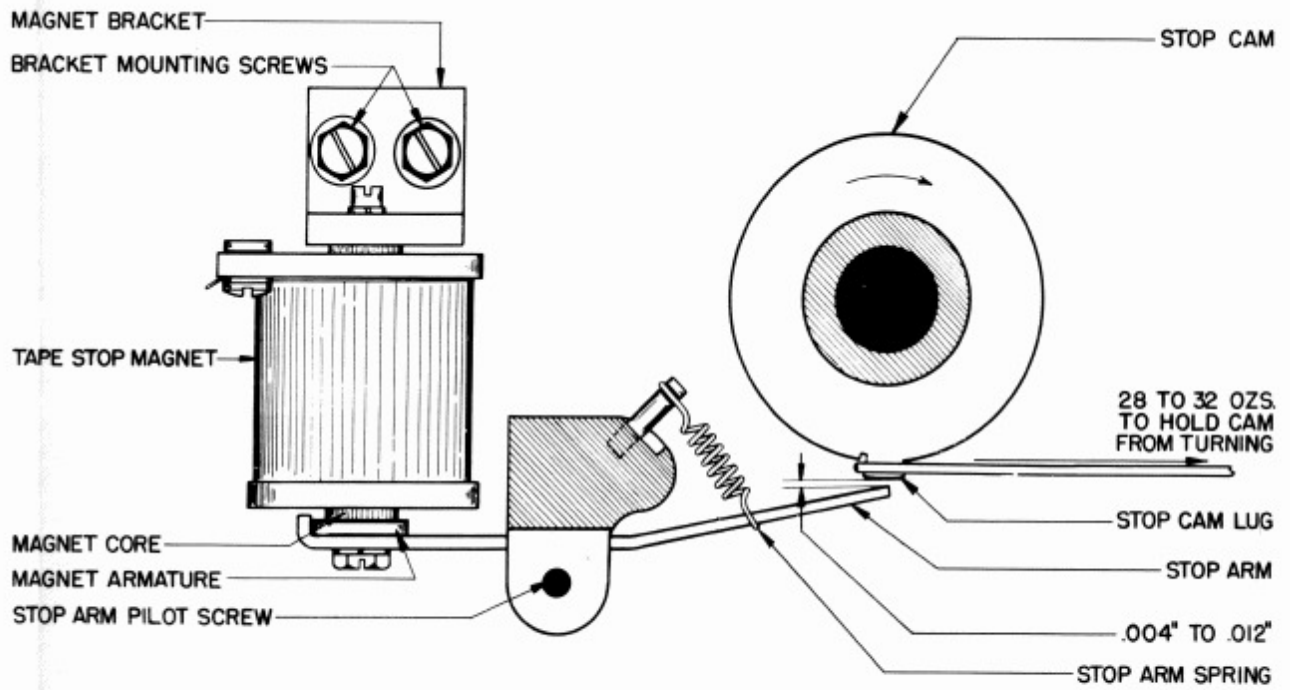

FIGURE 27

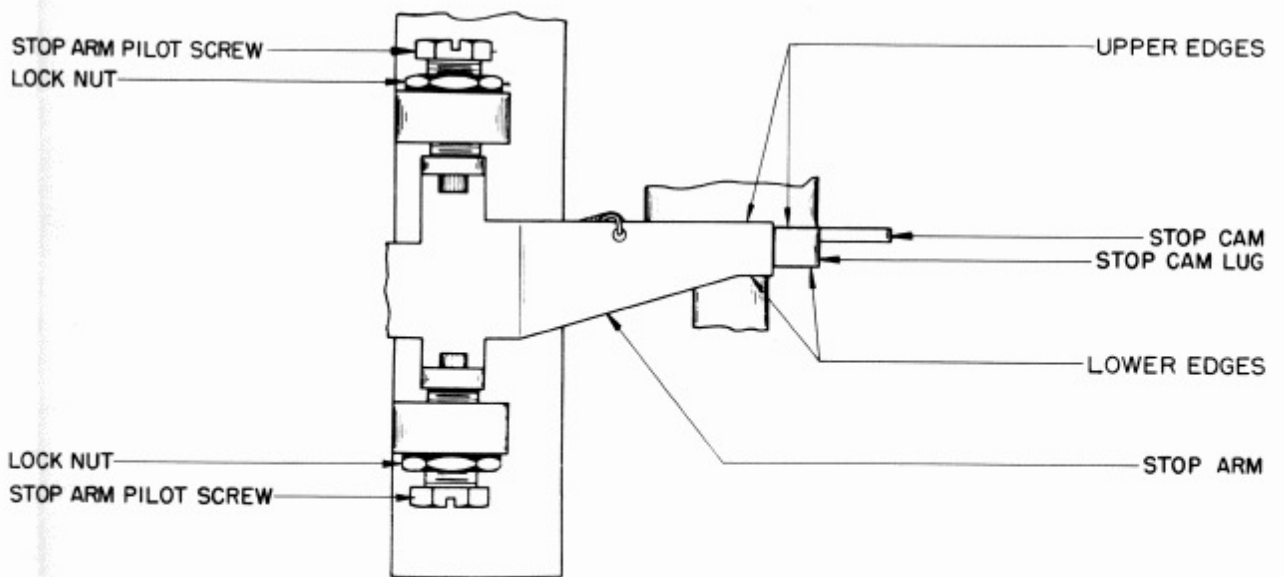

FIGURE 28

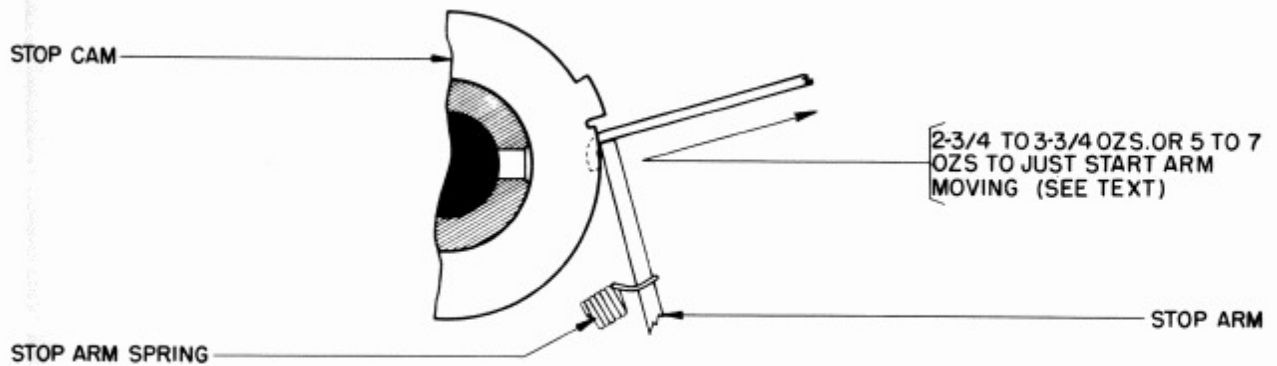

FIGURE 29

STOP CAM

141B

UPPER CONTACT BRACKET

STIFFENER

SHORT CONTACT SPRING

.015 TO .020 CONTACT GAP WHEN ARMATURE LEVER IS ON THE LOW PART OF ITS CAM.

PILE-UP MOUNTING SCREWS

LONG CONTACT SPRING

1 TO 1-1/2 OZS. TO BREAK CONTACT

INSULATOR

SOME CLEARANCE

STOP ARM

ARMATURE

28 TO 32 OZS. TO HOLD CAM FROM TURNING

STOP CAM LUG

STOP ARM

.004" TO .012"

STOP ARM SPRING

FIGURE 30

FEED PAWL

UPPER EDGES

1 TO 2 OZS. TO HOLD PAWL IN VERTICAL POSITION

FEED PAWL MOUNTING SCREW

FEED PAWL SPRING

FIGURE 31

DETENT LEVER (NEW STYLE)

12 TO 15 OZ

LOWER EDGES

(A)

DETENT LEVER (OLD STYLE)

15 TO 18 OZS. TO JUST START LEVER MOVING

DETENT ROLLER IN HOLLOW BETWEEN TWO TEETH

FEED WHEEL RATCHET

DETENT LEVER SPRING

3-3/4 OZS. OR 5 TO 7 JUST START ARM (SEE TEXT)

MOUNTING SCREWS

TAPE TRANSMITTER TOP PLATE

FEED-WHEEL SHAFT BEARING

(B)

FIGURE 32

STOP ARM

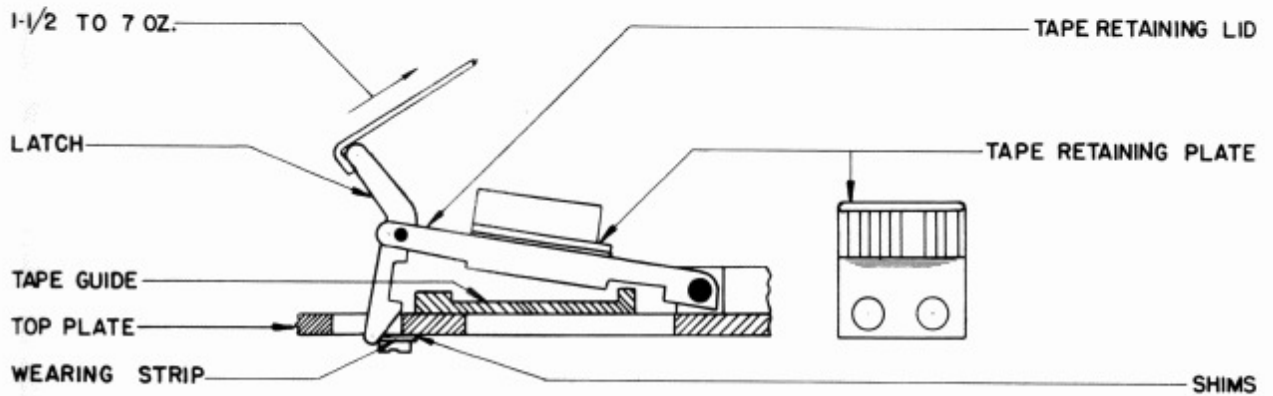

FIGURE 33

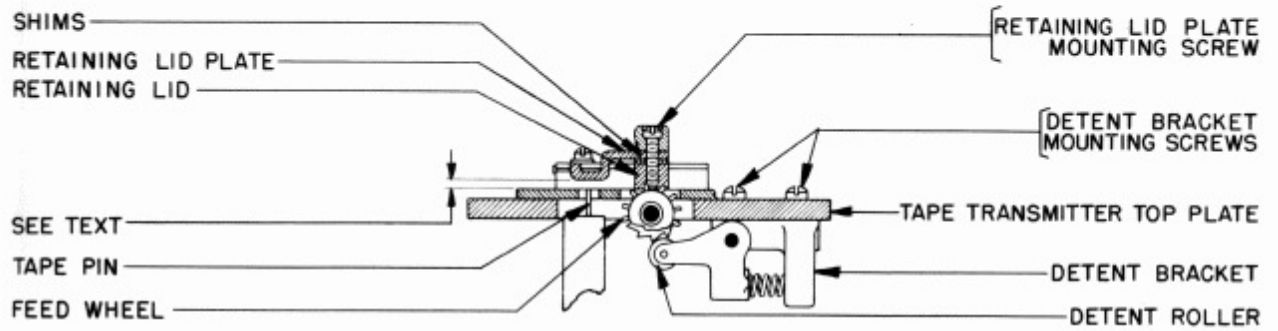

FIGURE 34

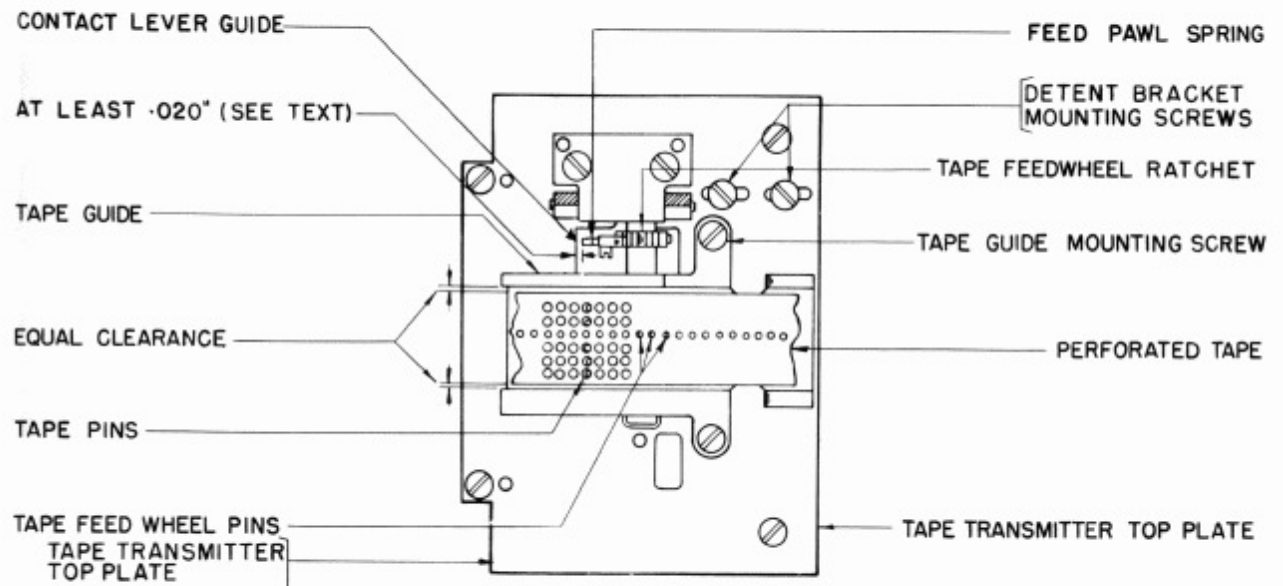
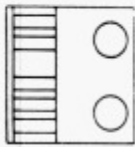

FIGURE 35

TAPE RETAINING LID

TAPE RETAINING PLATE



(A)

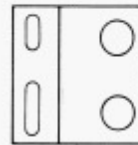

(B)

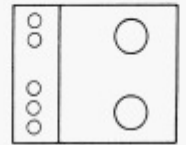

(C)

FIGURE 36

SHIMS

RETAINING LID PLATE MOUNTING SCREW

DETENT BRACKET MOUNTING SCREWS

TRANSMITTER TOP PLATE

DETENT BRACKET

DETENT ROLLER

FEED PAWL SPRING

DETENT BRACKET MOUNTING SCREWS

FEEDWHEEL RATCHET

WIDE MOUNTING SCREW

PERFORATED TAPE

TRANSMITTER TOP PLATE

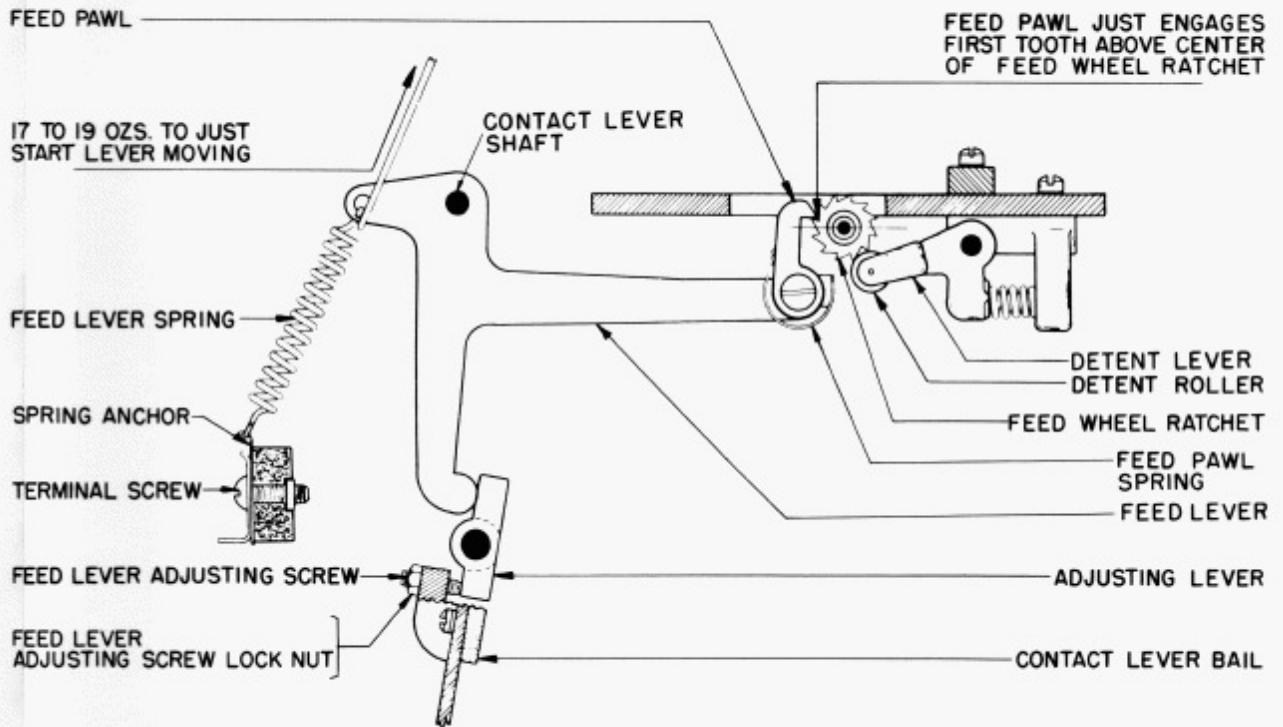

FIGURE 37

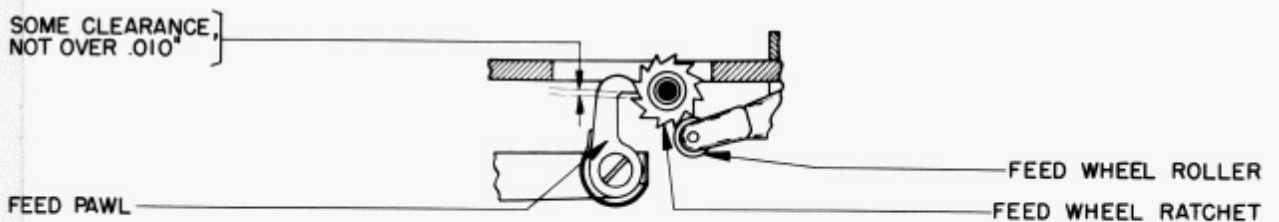

FIGURE 38

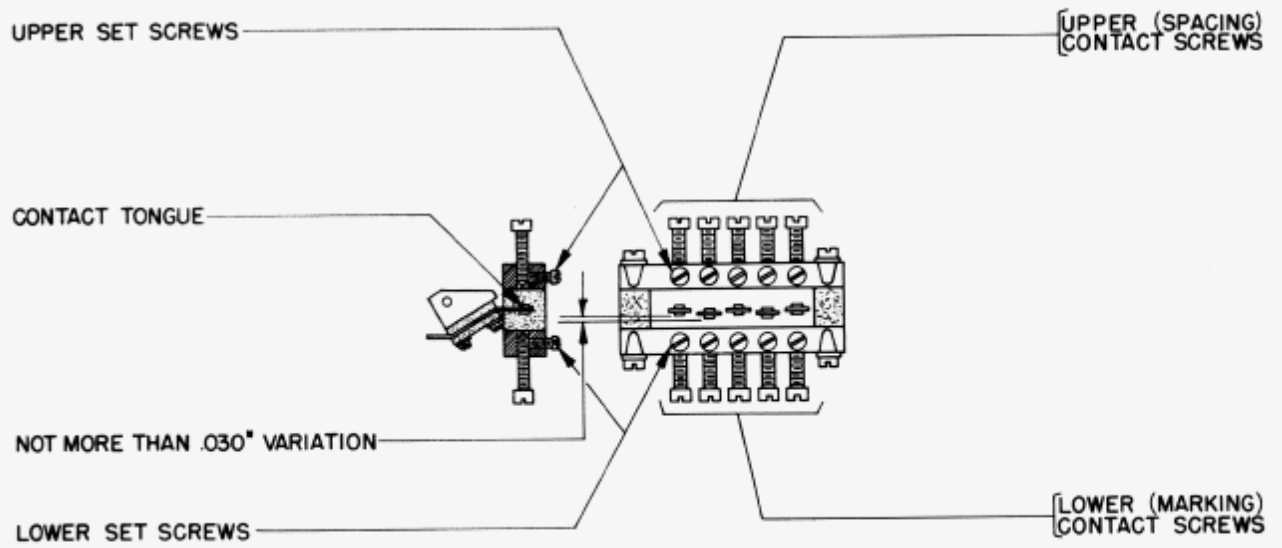

FIGURE 39

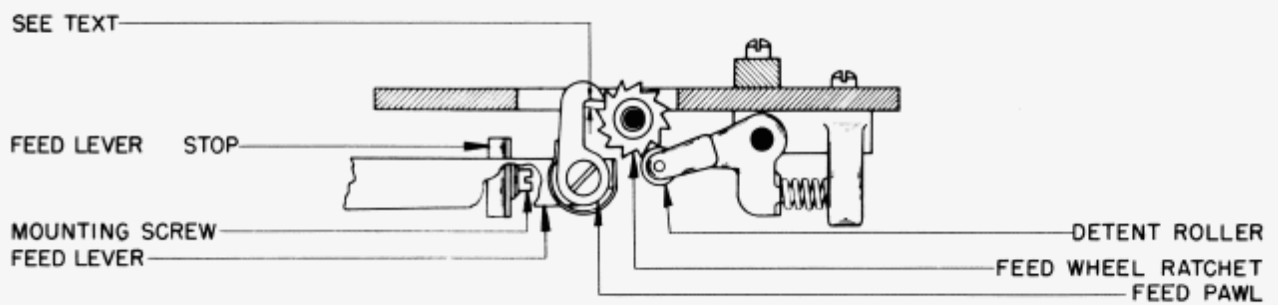

FIGURE 40

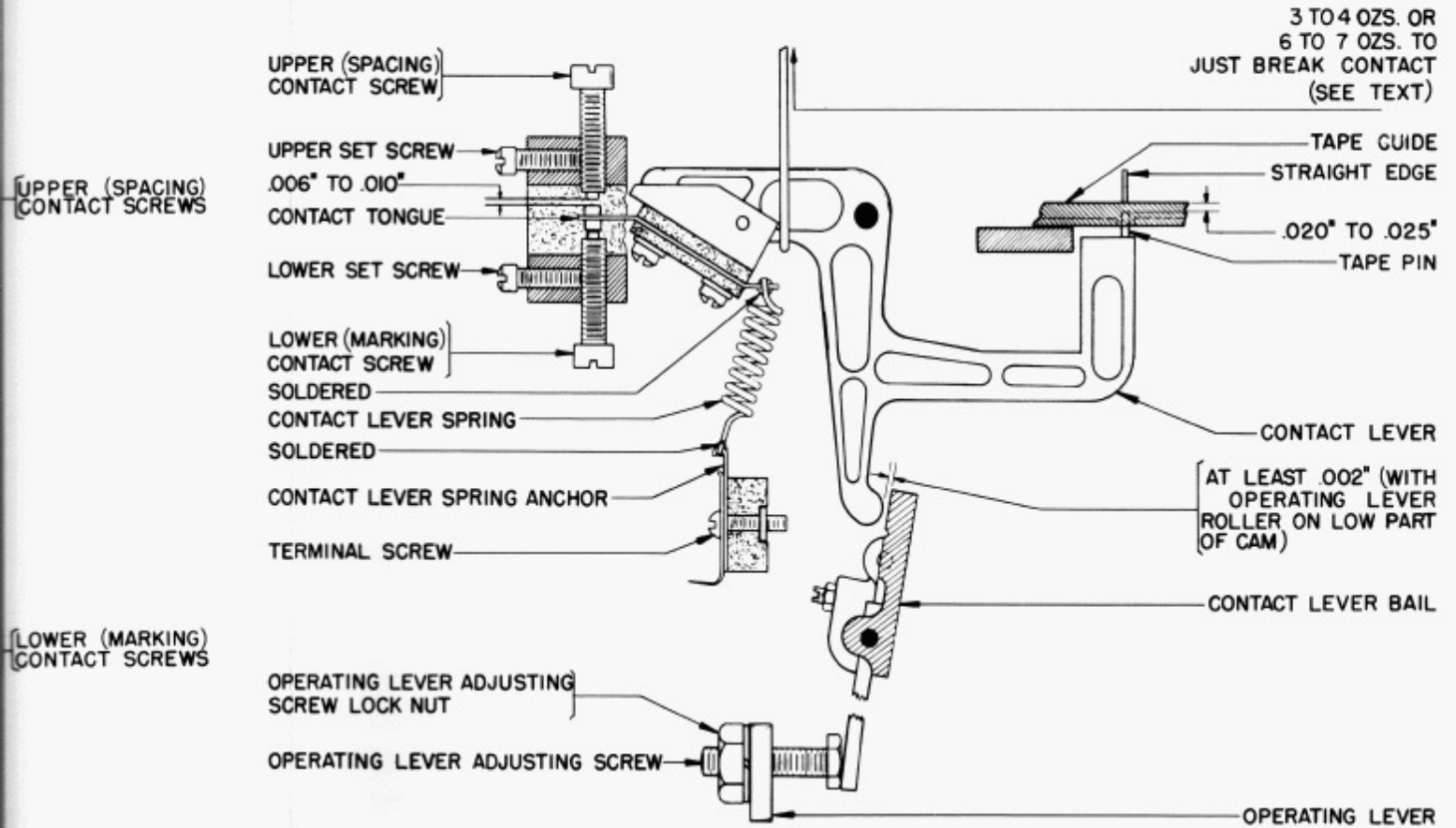

FIGURE 41

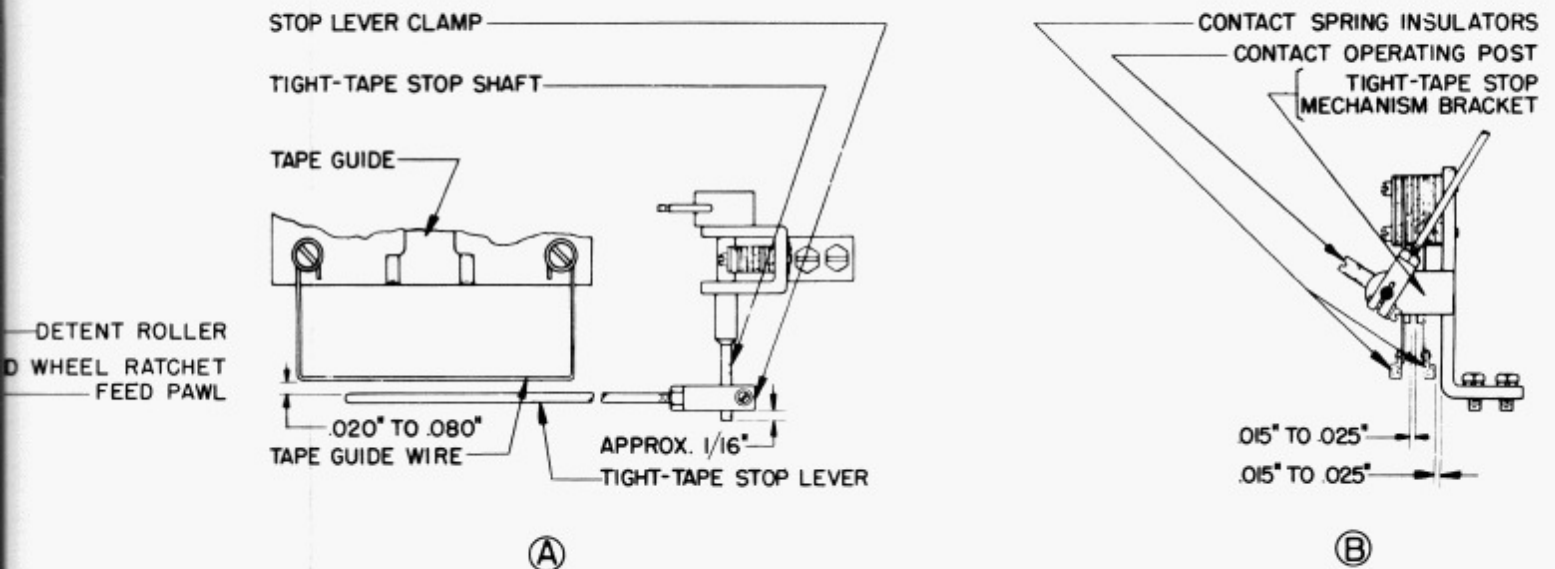

FIGURE 42

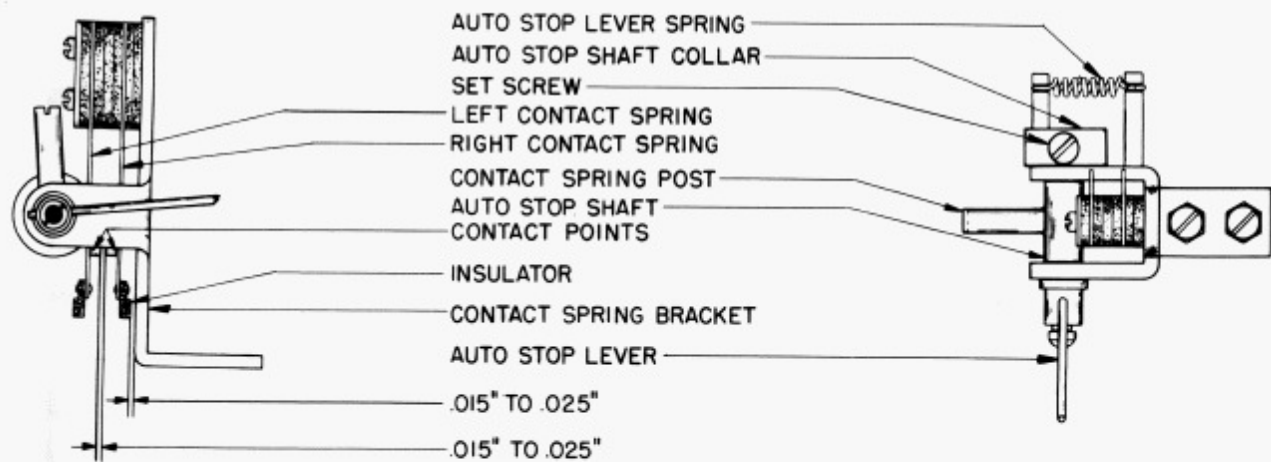

FIGURE 43

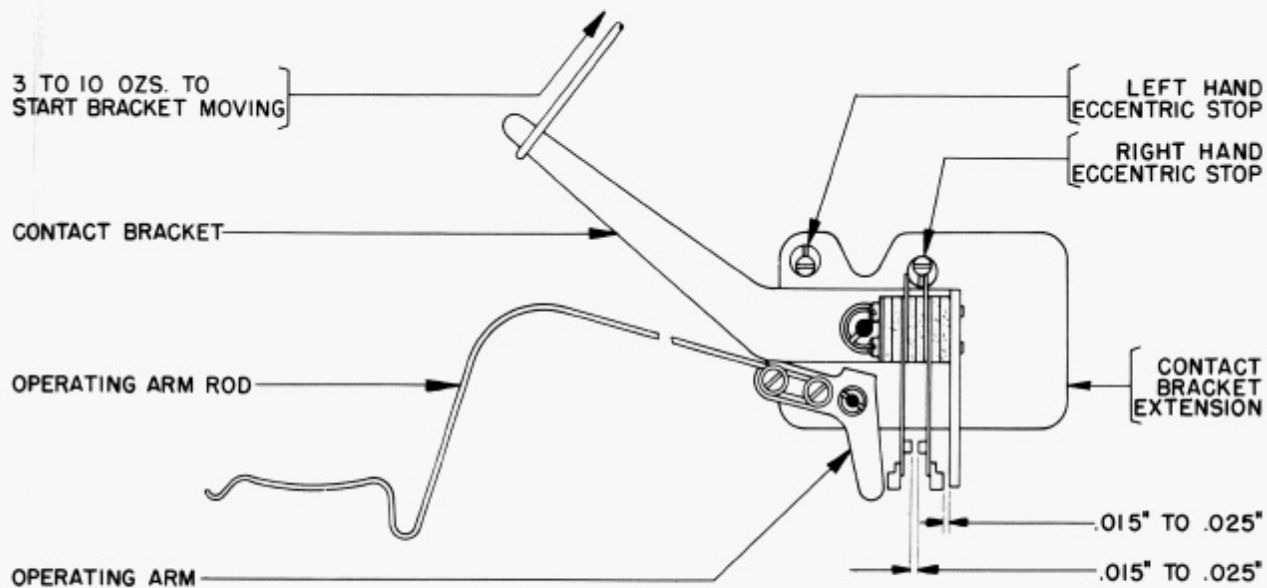

FIGURE 44

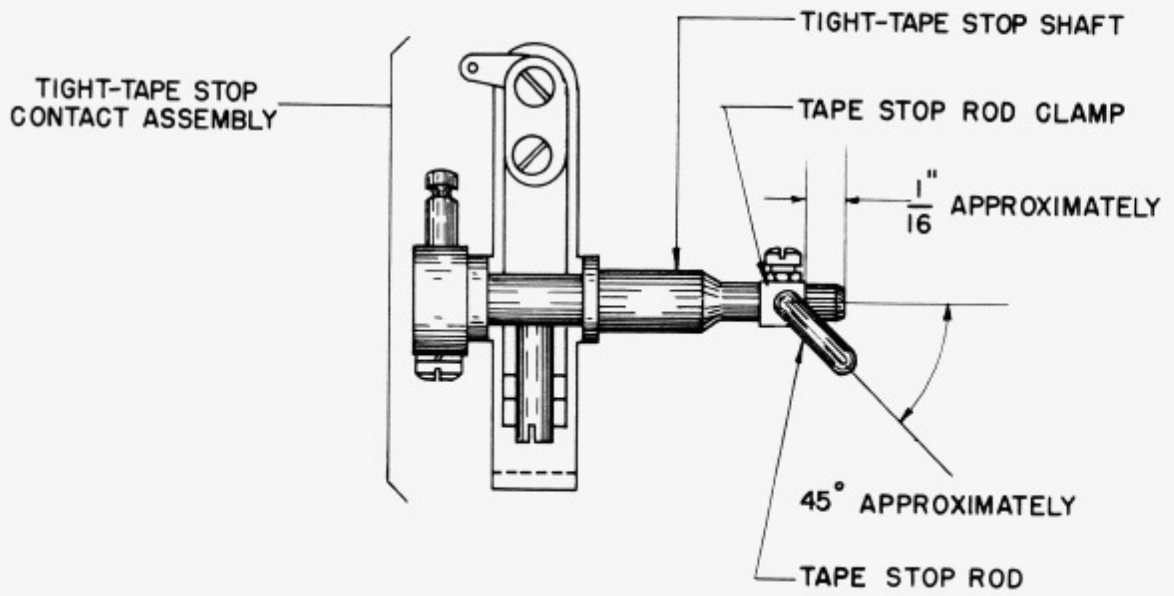

FIGURE 45 A

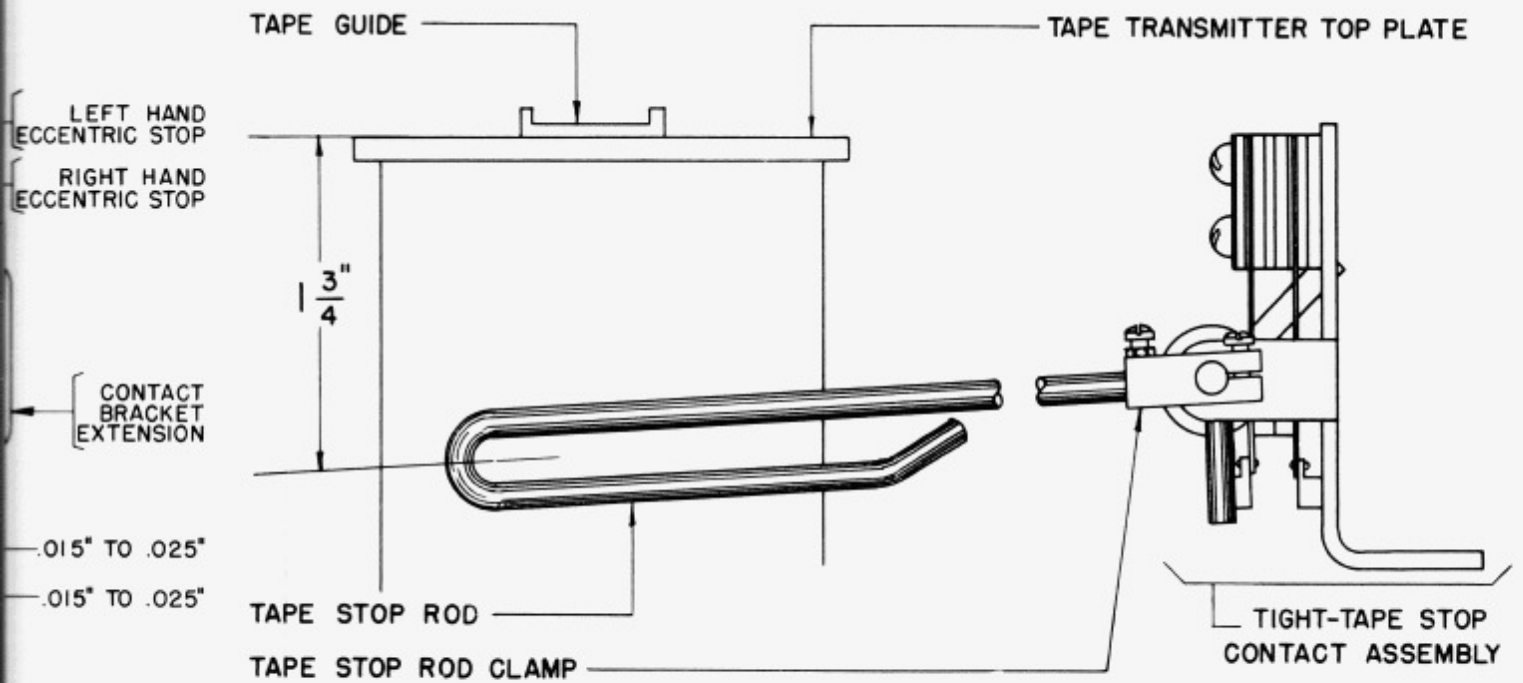

FIGURE 45 B

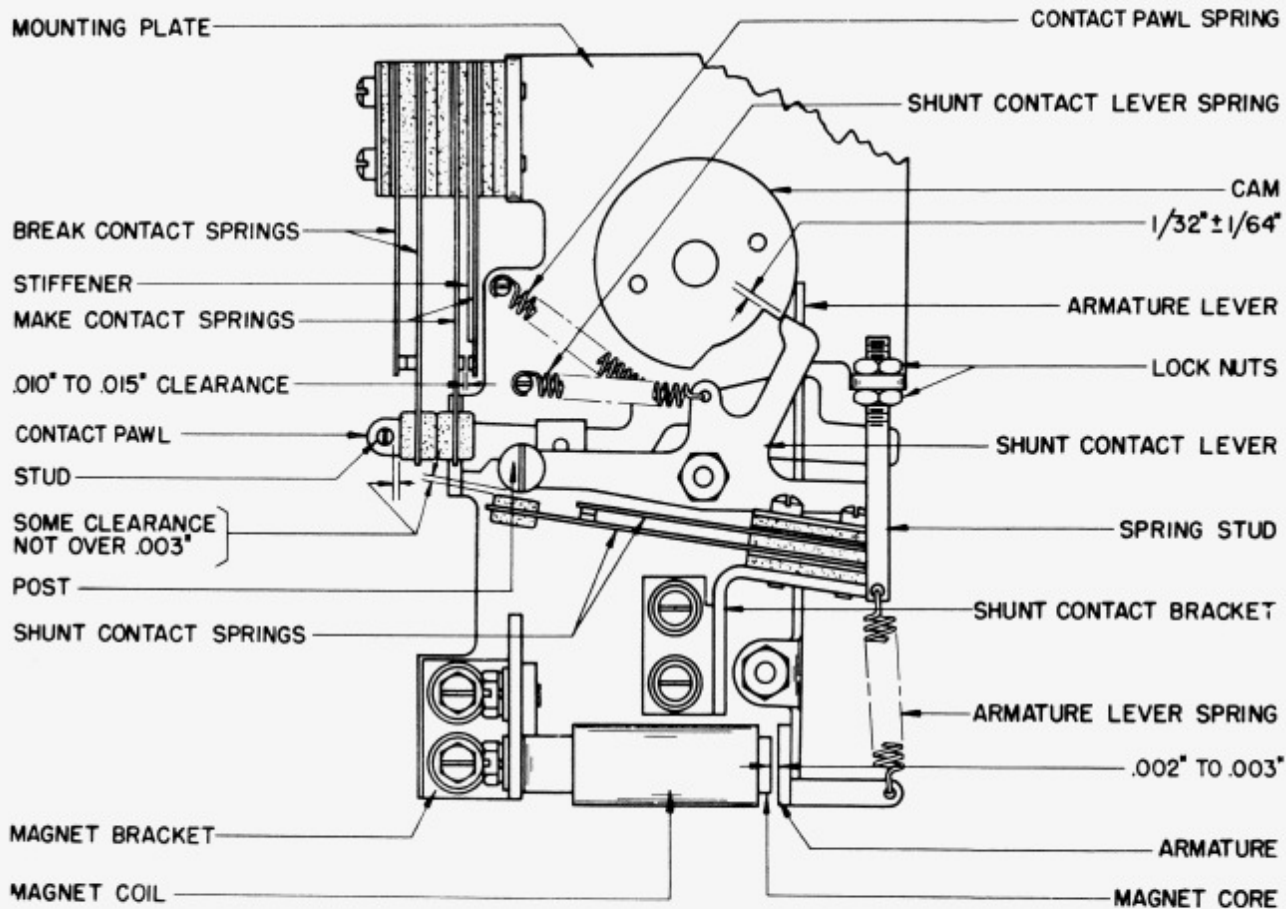

FIGURE 46

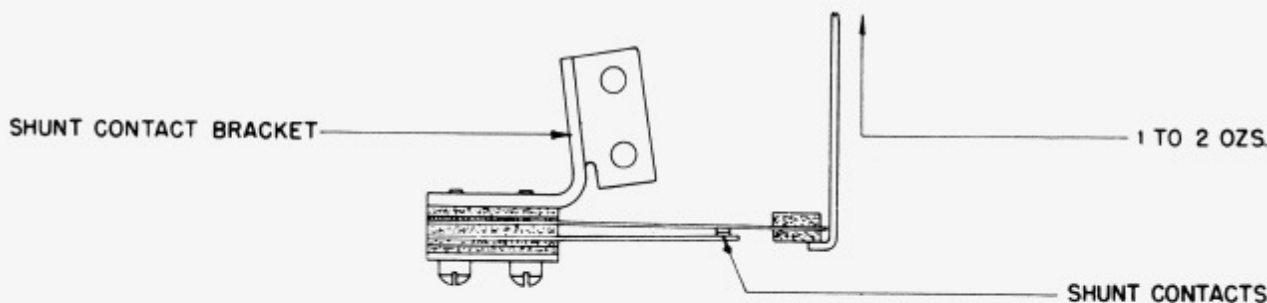

FIGURE 47

CONTACT PAWL SPRING
 CONTACT LEVER SPRING
 CAM
 $1/32" \pm 1/64"$
 ARMATURE LEVER
 LOCK NUTS
 SHUNT CONTACT LEVER
 SPRING STUD
 CONTACT BRACKET
 ARMATURE LEVER SPRING
 $.002" \text{ TO } .003"$
 ARMATURE
 MAGNET CORE

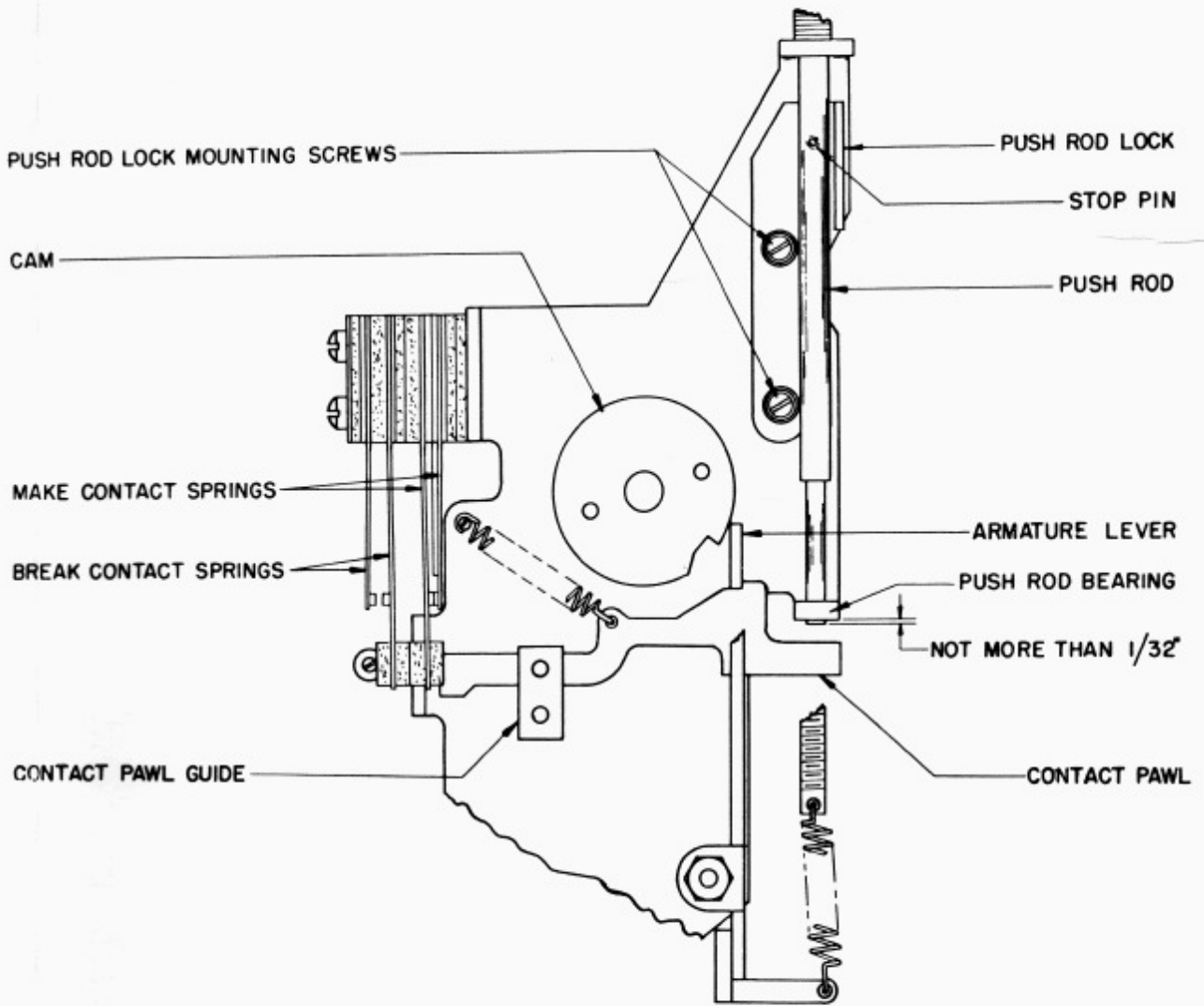

FIGURE 48

1 TO 2 OZS.
 SHUNT CONTACTS

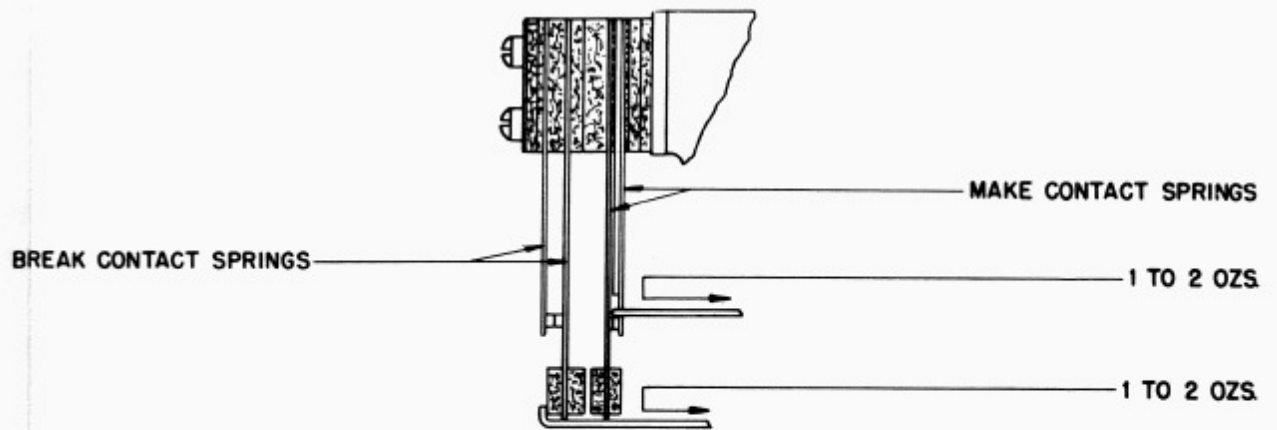

FIGURE 49

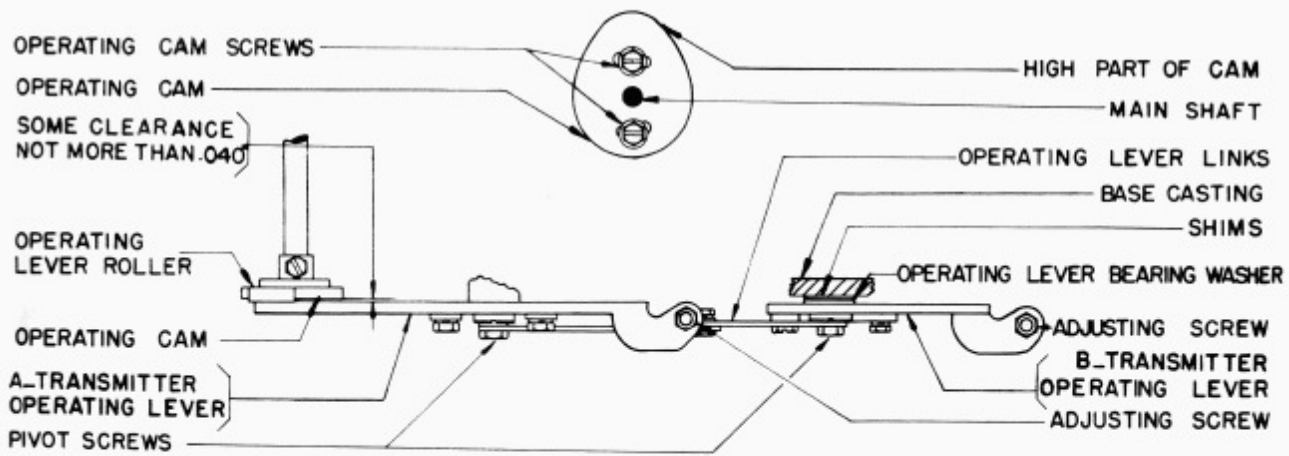

FIGURE 50

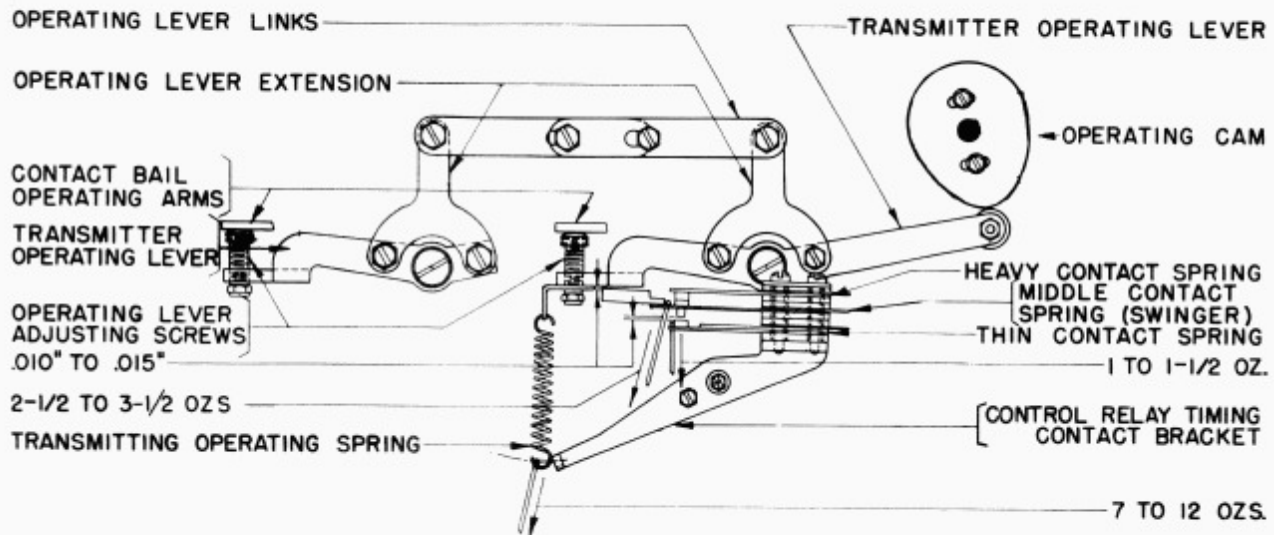

FIGURE 51

HIGH PART OF CAM
 MAIN SHAFT
 OPERATING LEVER LINKS
 BASE CASTING
 SHIMS
 LEVER BEARING WASHER
 ADJUSTING SCREW
 B-TRANSMITTER
 OPERATING LEVER
 ADJUSTING SCREW

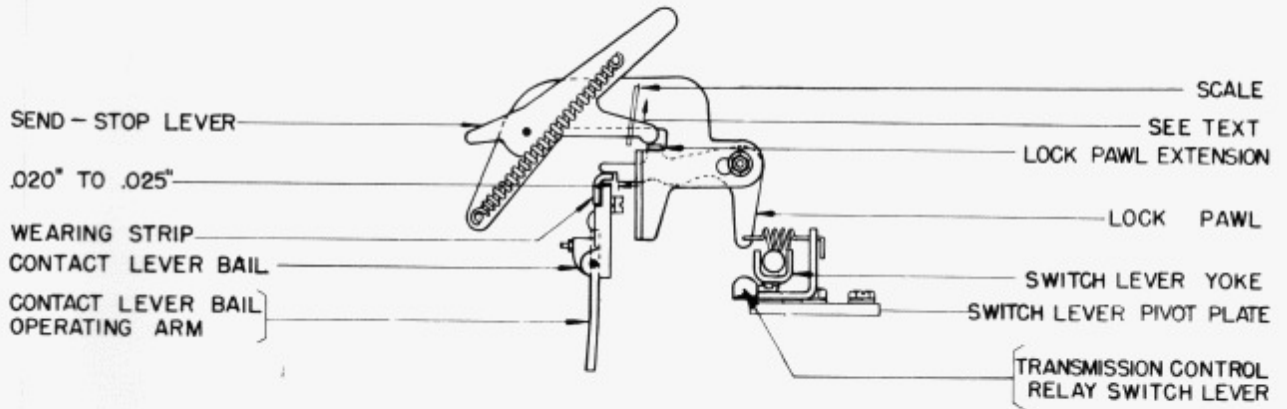

FIGURE 52

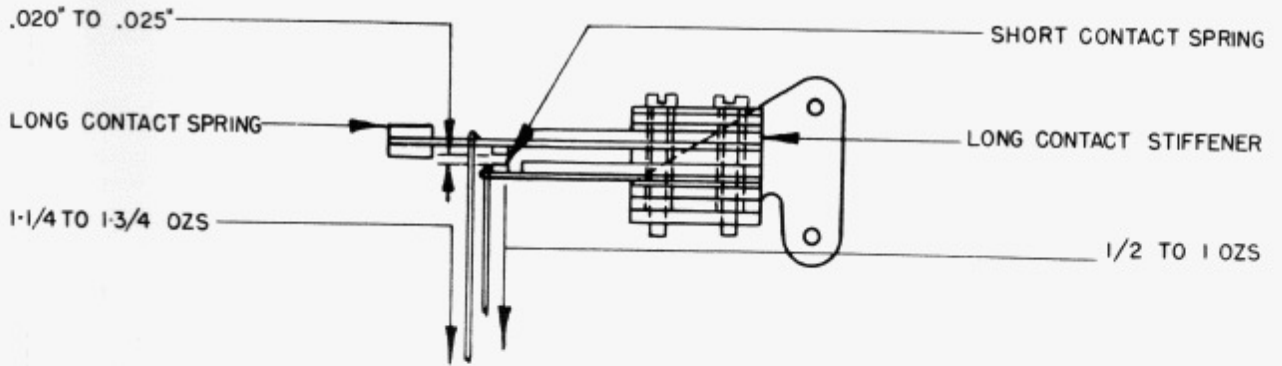

FIGURE 53

OPERATING LEVER
 OPERATING CAM
 CONTACT SPRING
 MIDDLE CONTACT
 SPRING (SWINGER)
 CONTACT SPRING
 1 TO 1-1/2 OZ.
 CONTROL RELAY TIMING
 CONTACT BRACKET
 7 TO 12 OZS.

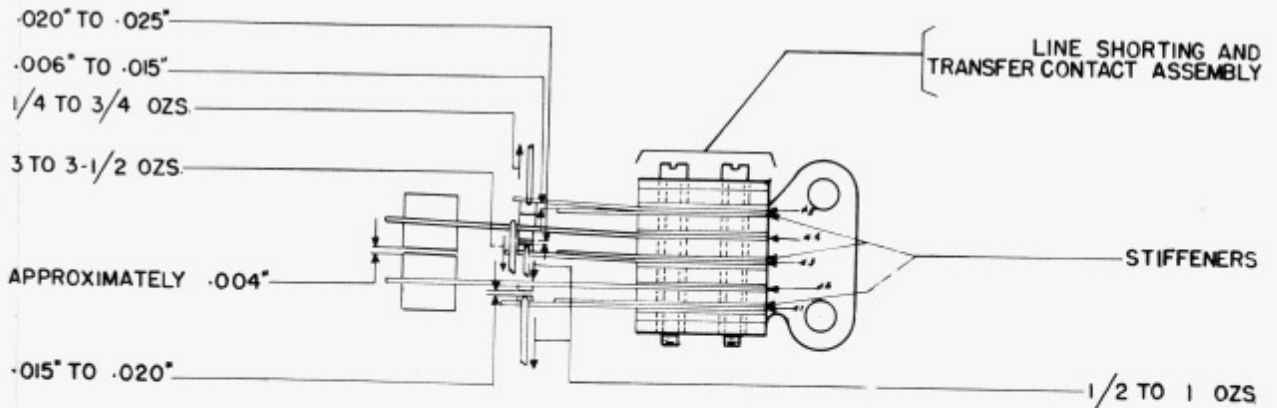

FIGURE 54

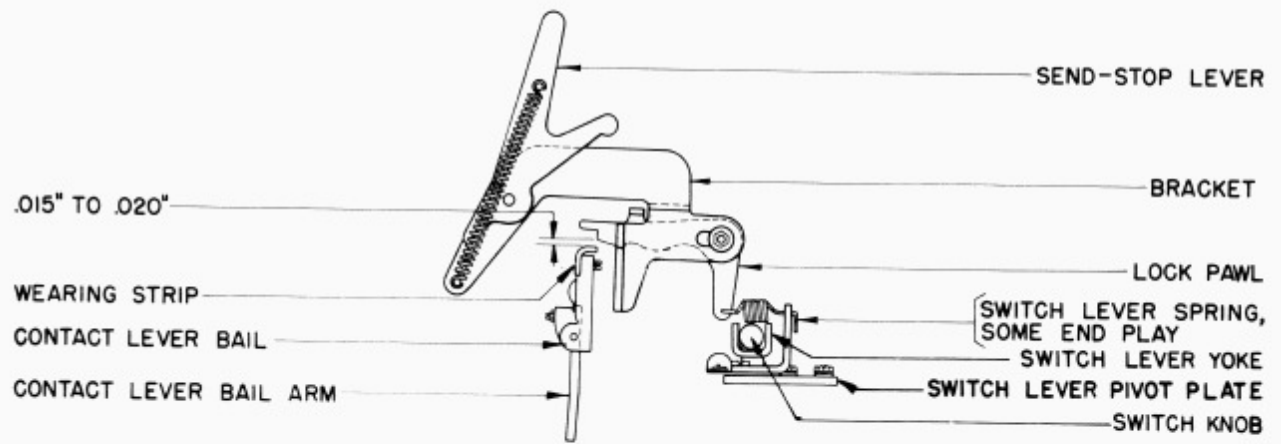

FIGURE 55

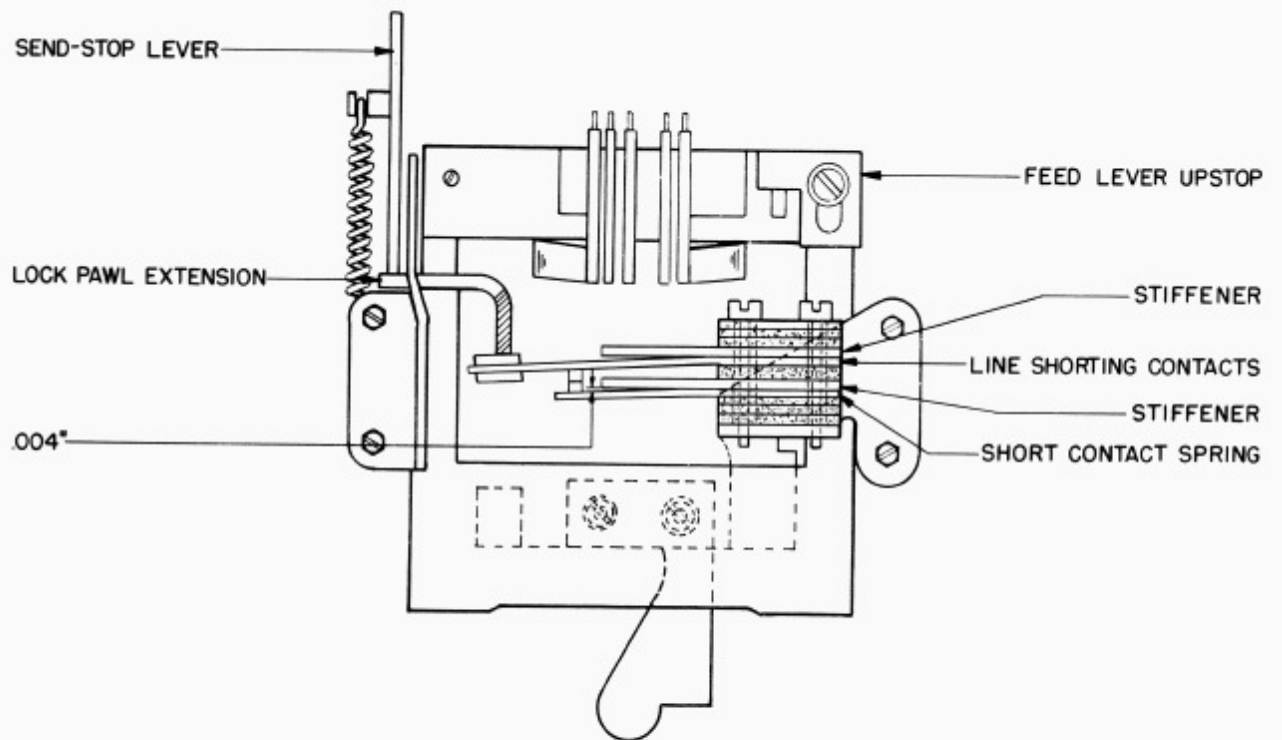

FIGURE 56

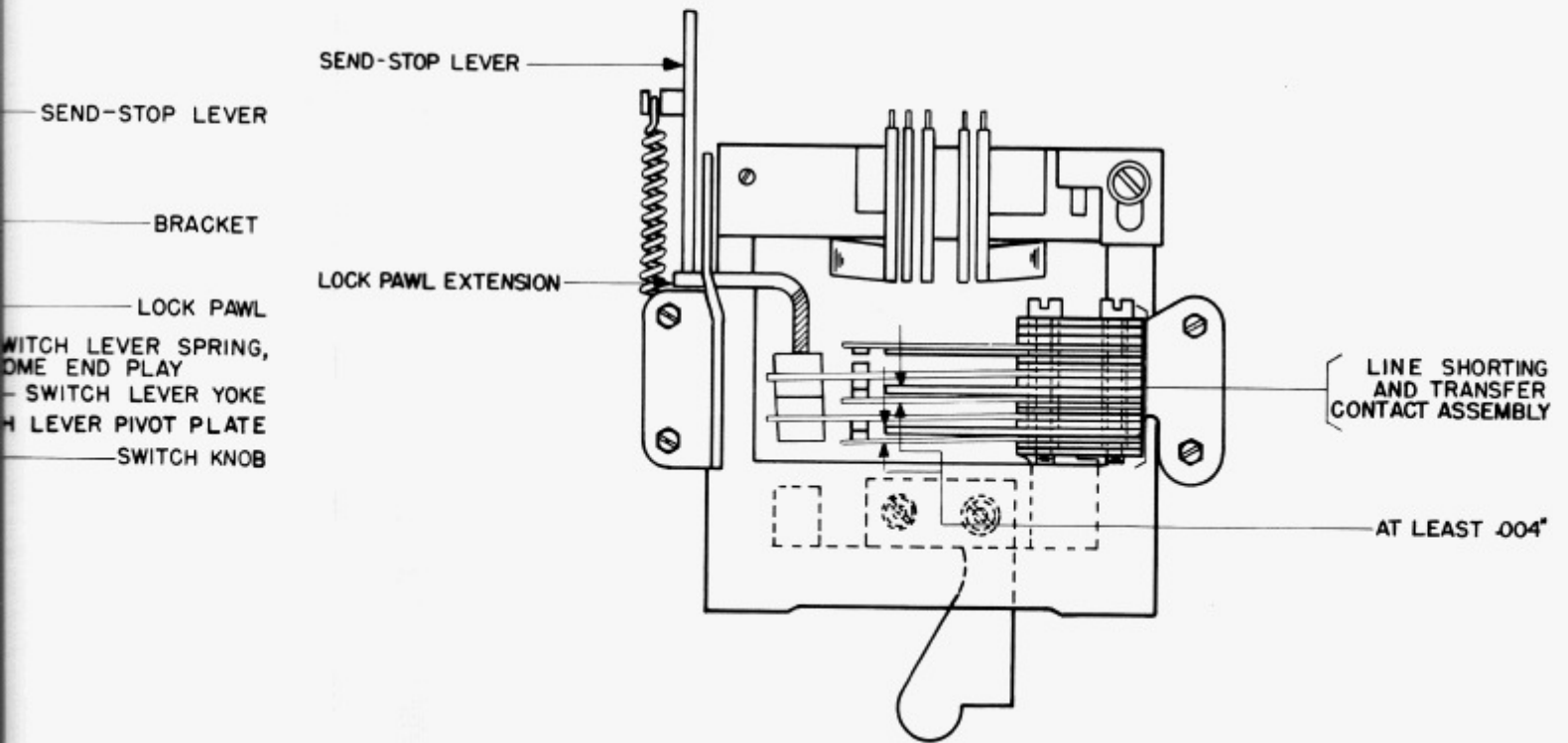

FIGURE 57

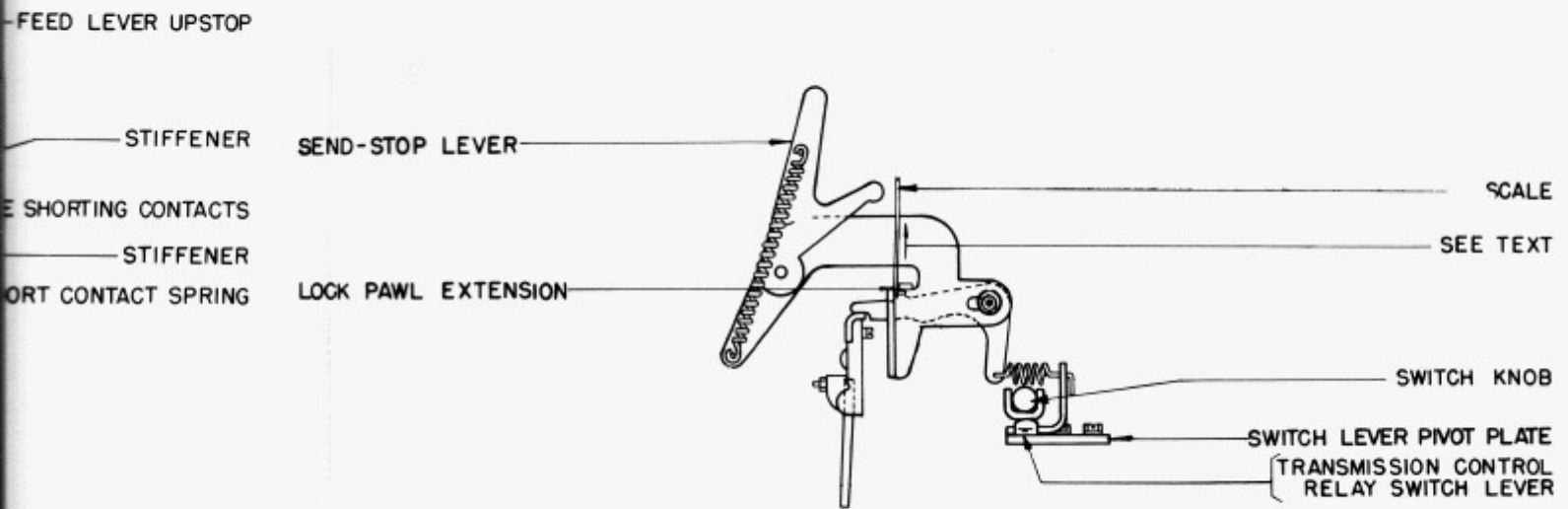

FIGURE 58

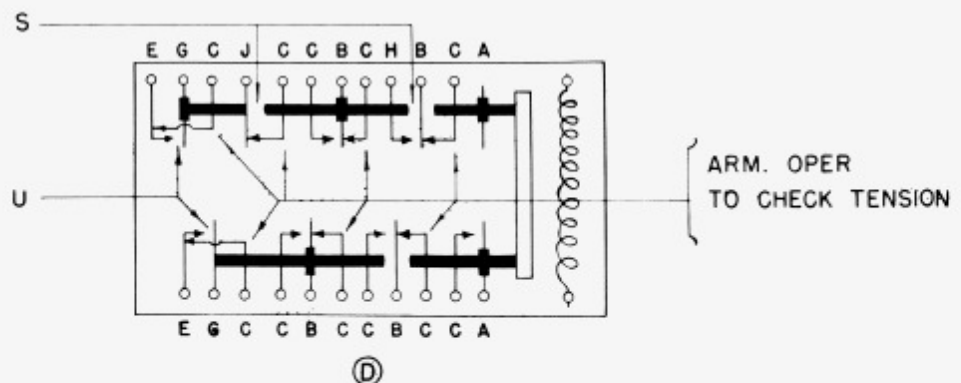
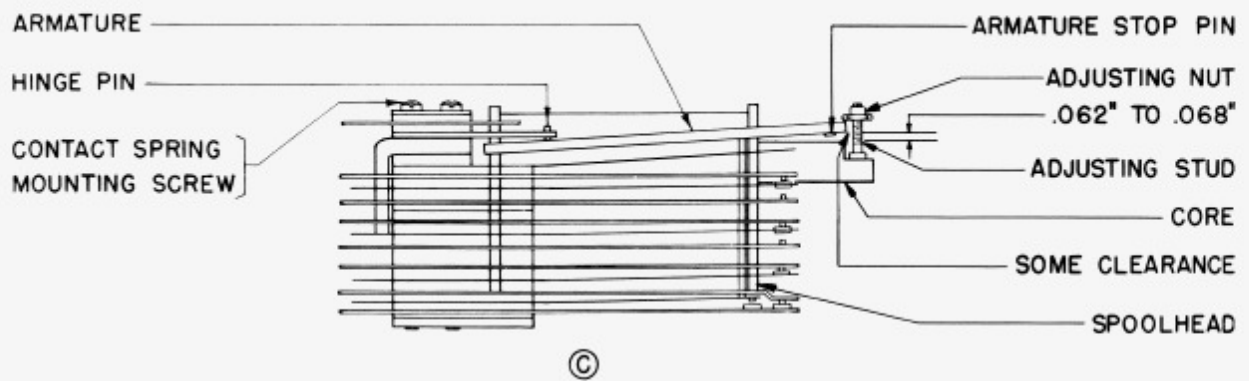
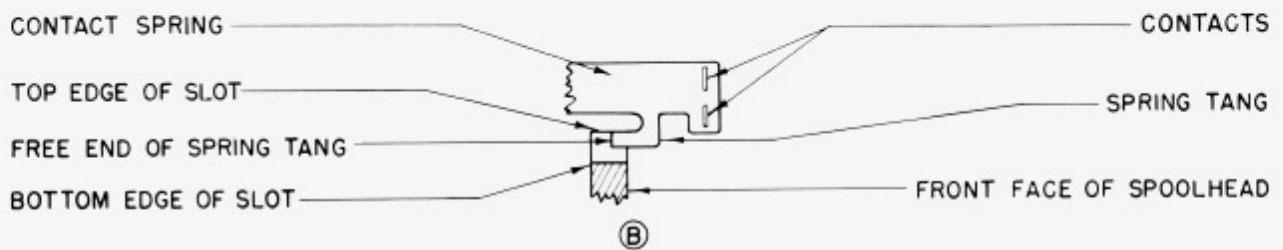
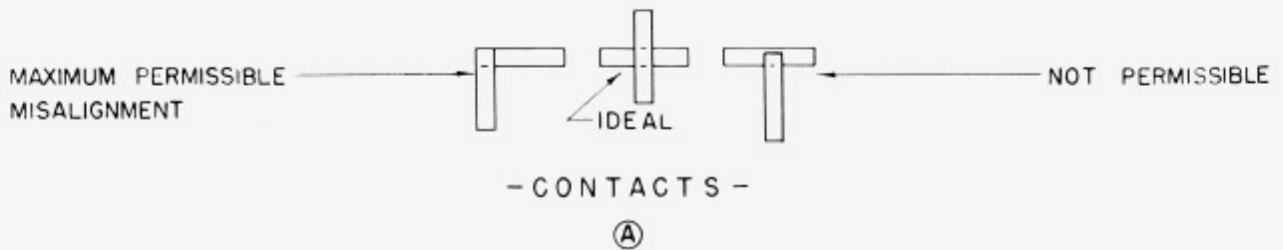

FIGURE 59

141B

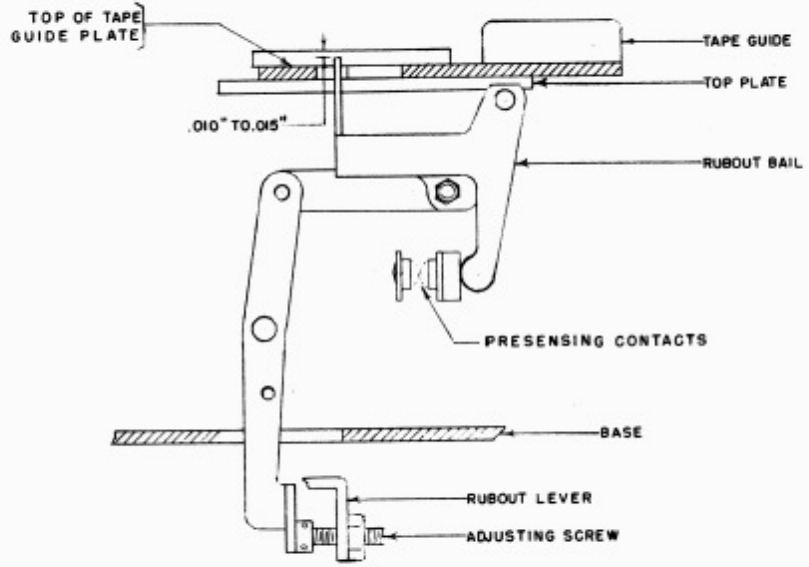

FIGURE 60

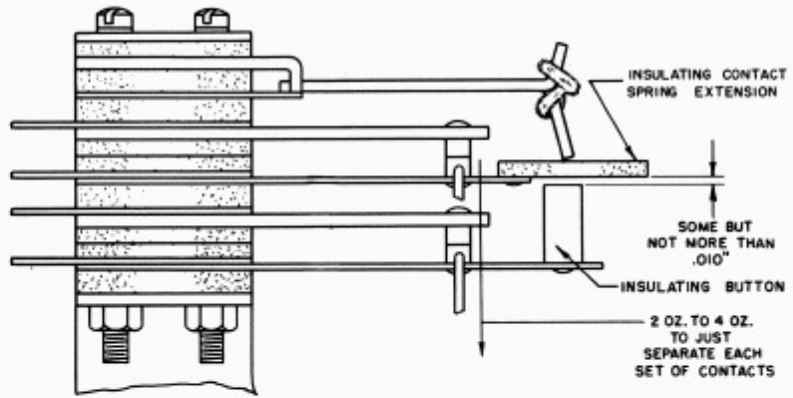
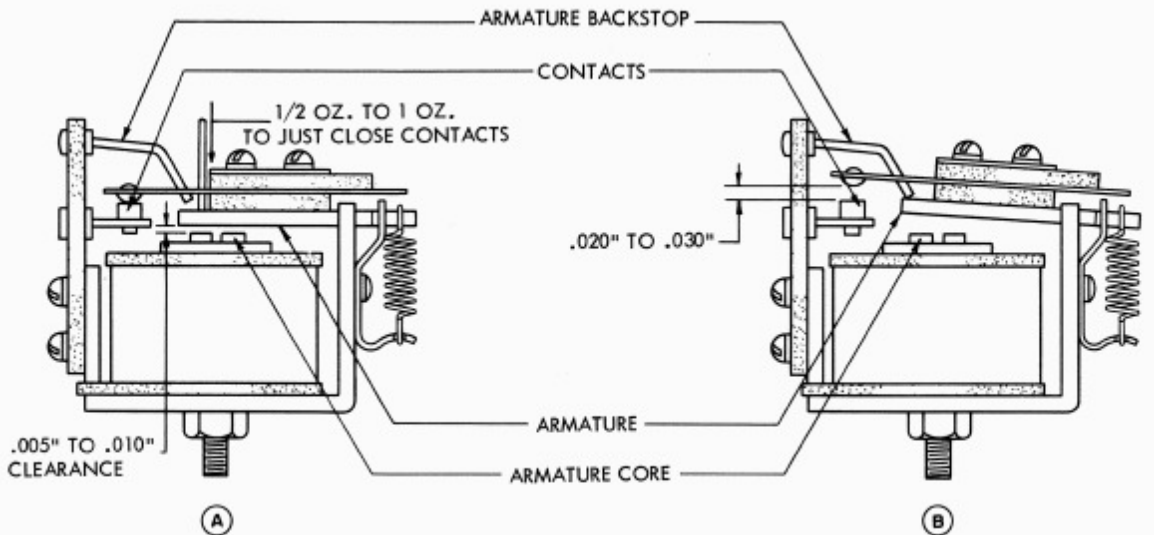

FIGURE 61



(A)

(B)

NOT PERMISSIBLE

CONTACTS

SPRING TANG

FRONT FACE OF SPOOLHEAD

ARMATURE STOP PIN

ADJUSTING NUT

.062" TO .068"

ADJUSTING STUD

CORE

SOME CLEARANCE

SPOOLHEAD

ARM. OPER
TO CHECK TENSION

.005" TO .010"
CLEARANCE

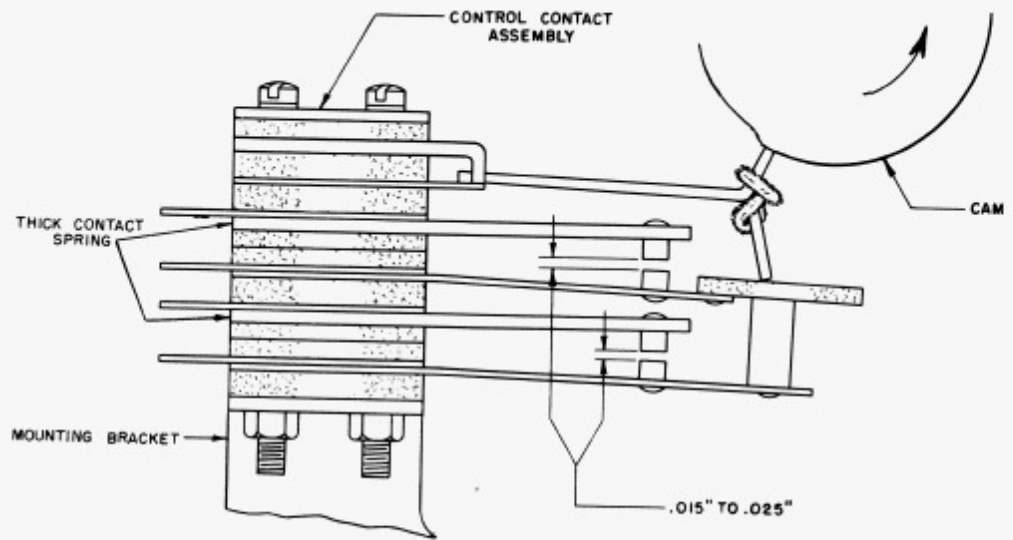

FIGURE 63

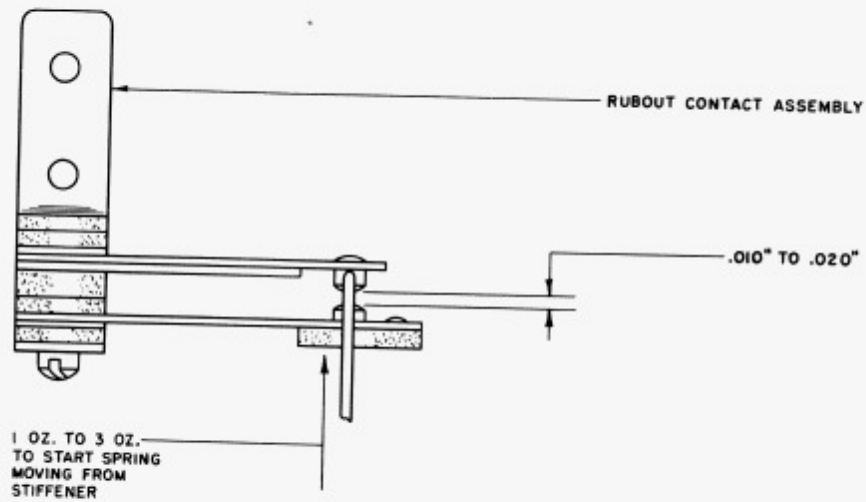

FIGURE 64

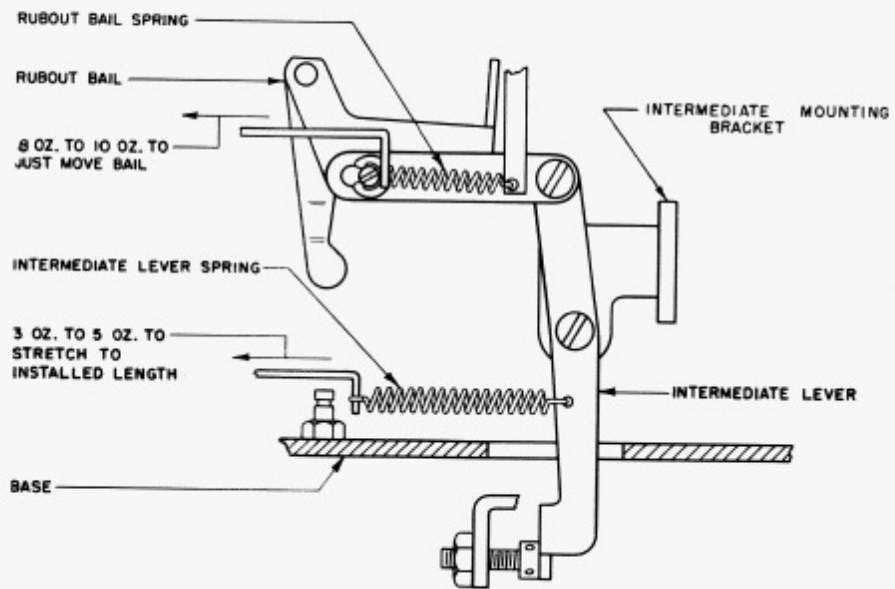

FIGURE 65

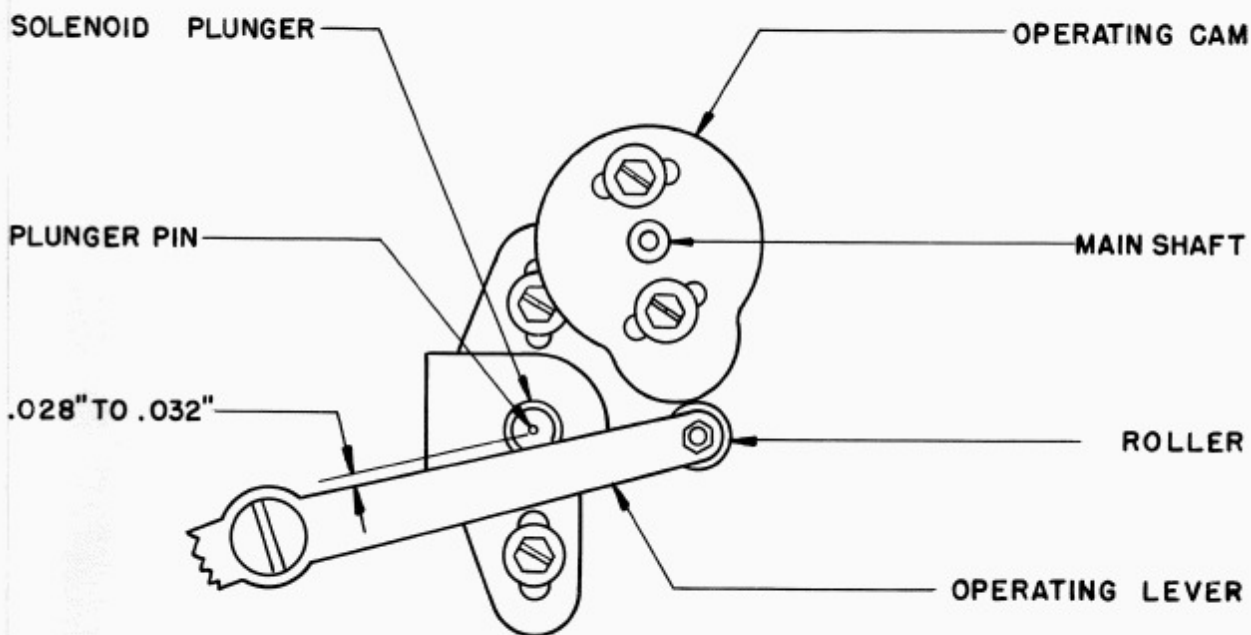

FIGURE 66

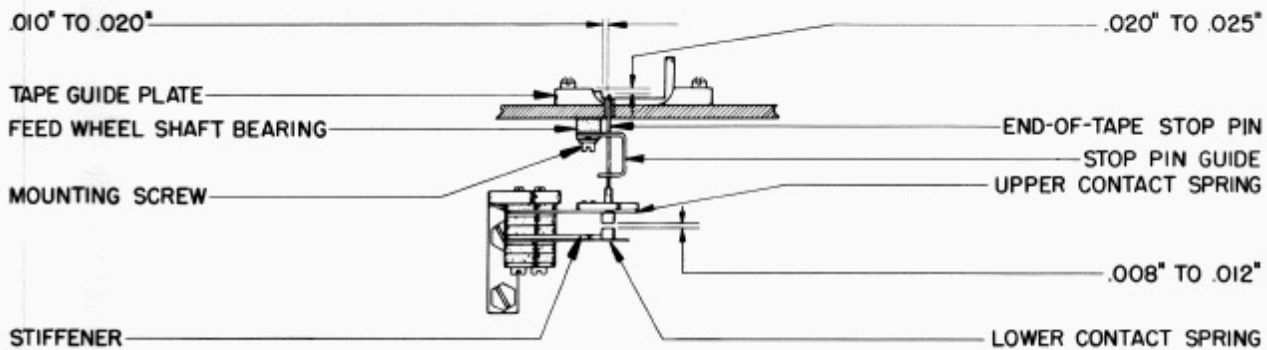
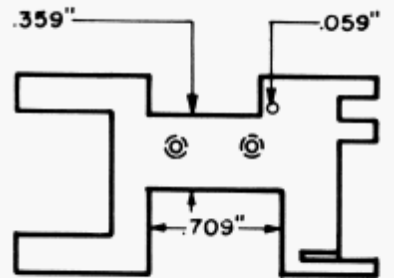
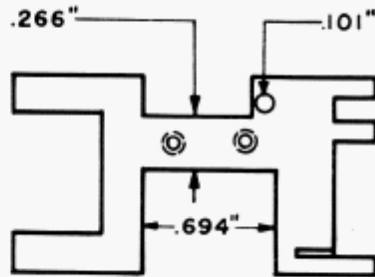
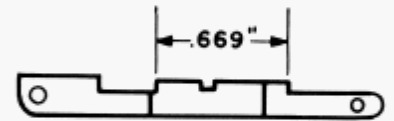
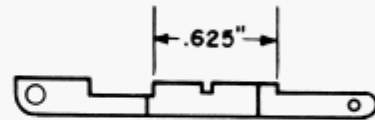

FIGURE 67



(A)

(B)

FIGURE 68

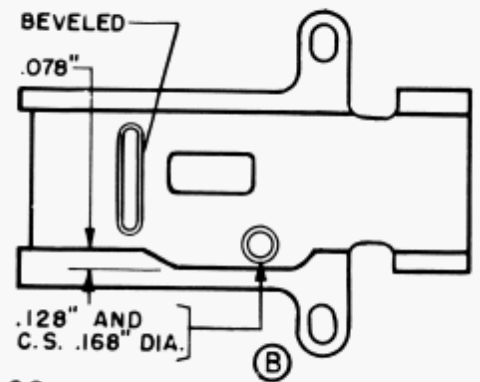
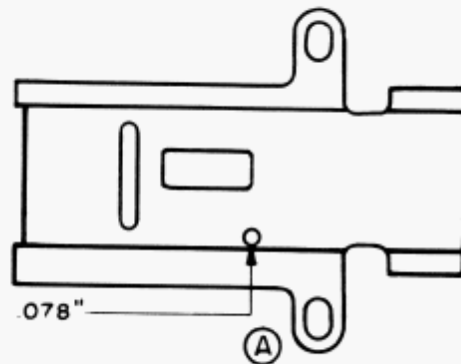

FIGURE 69

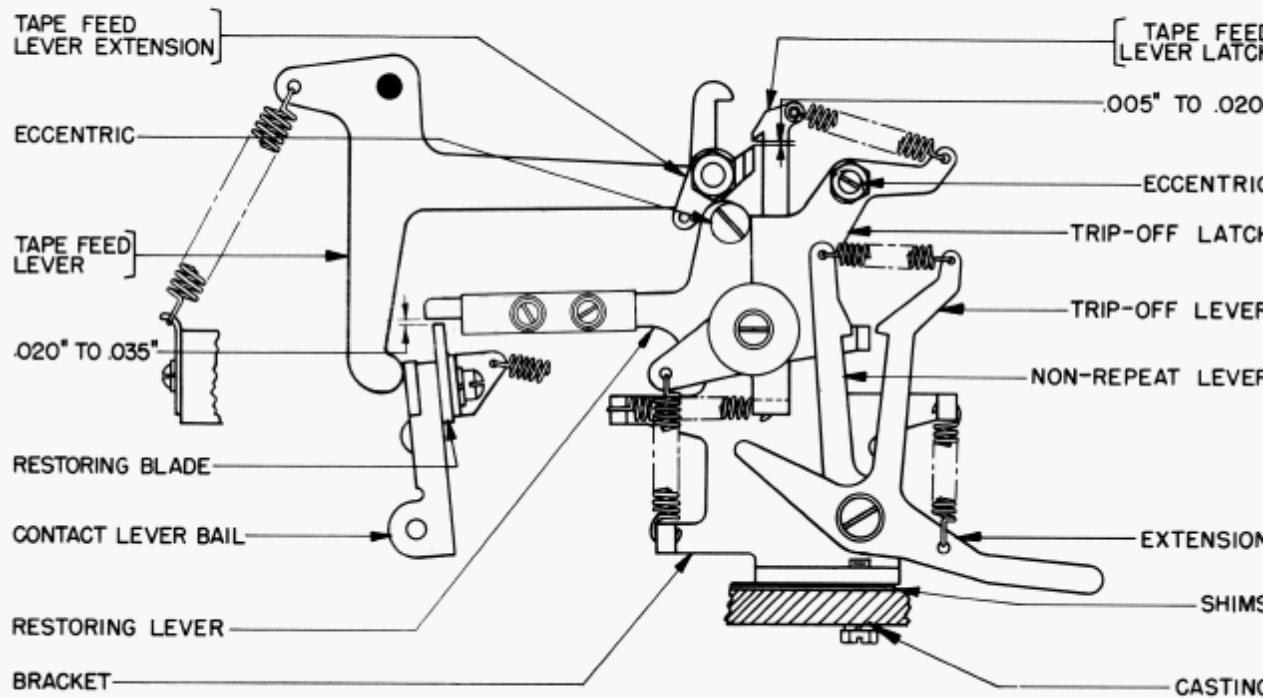

FIGURE 70

141B

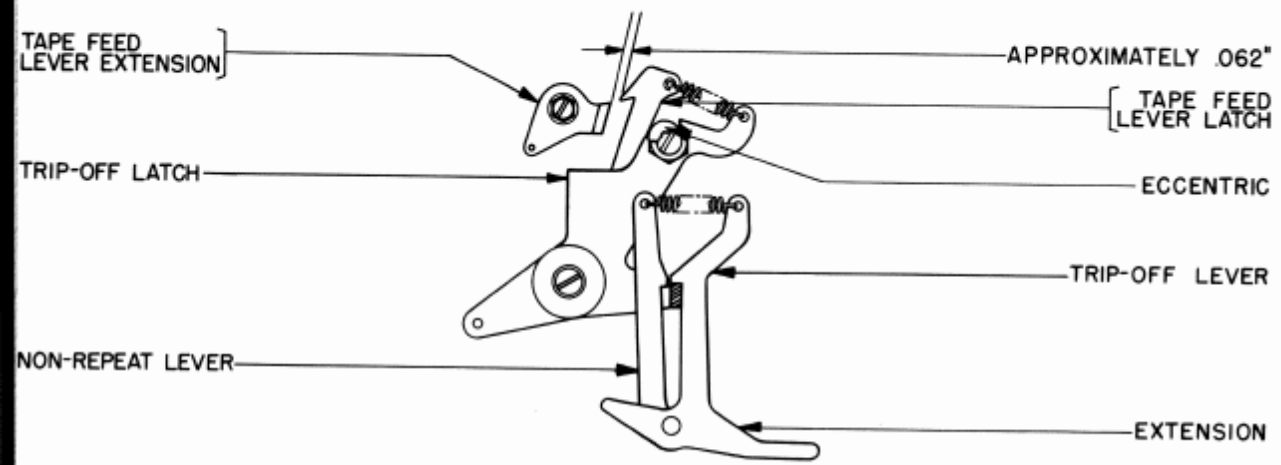

FIGURE 71

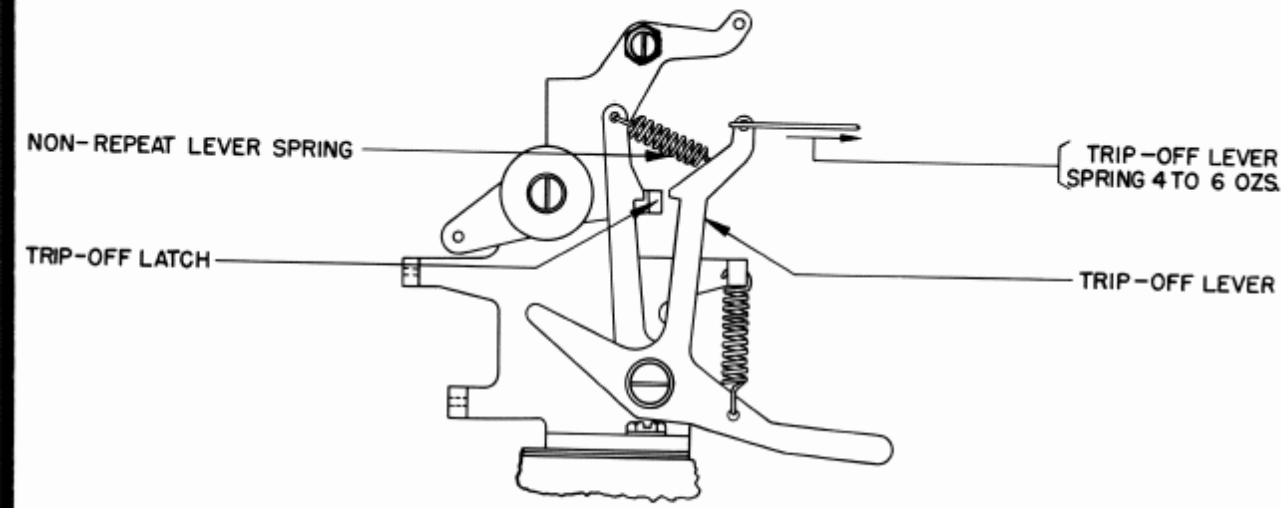

FIGURE 72

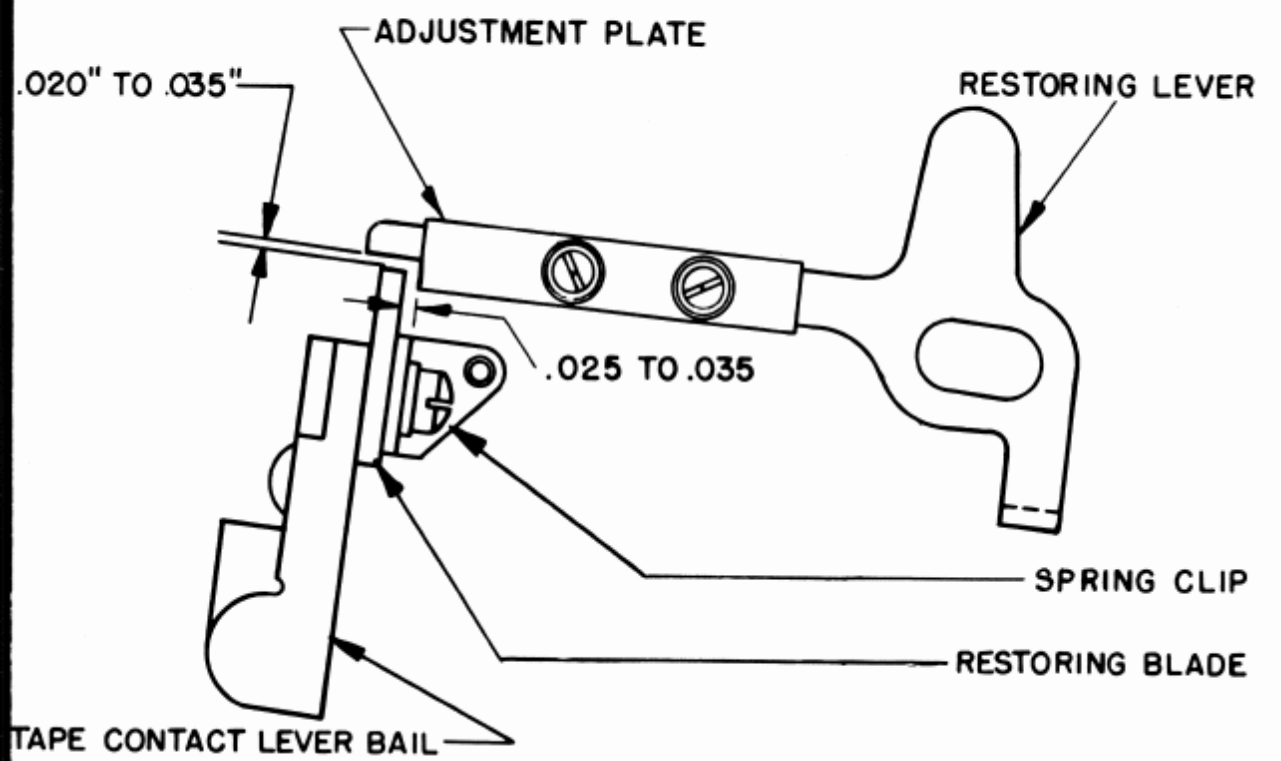

FIGURE 73

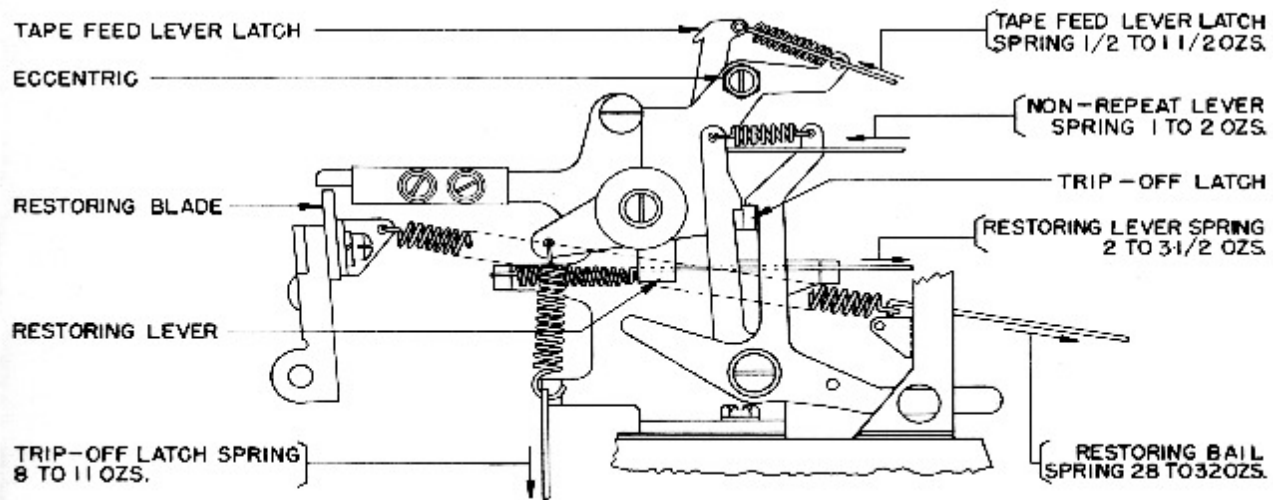

FIGURE 74

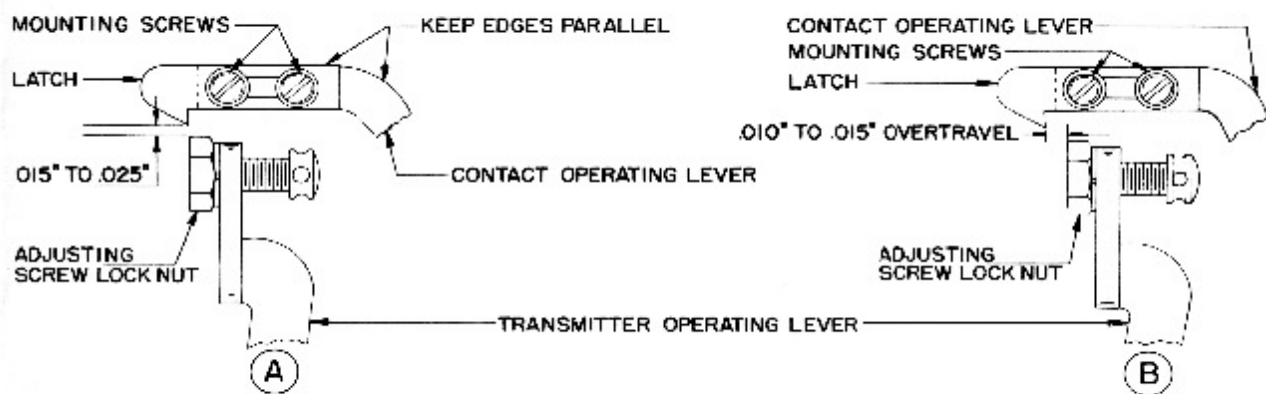

FIGURE 75

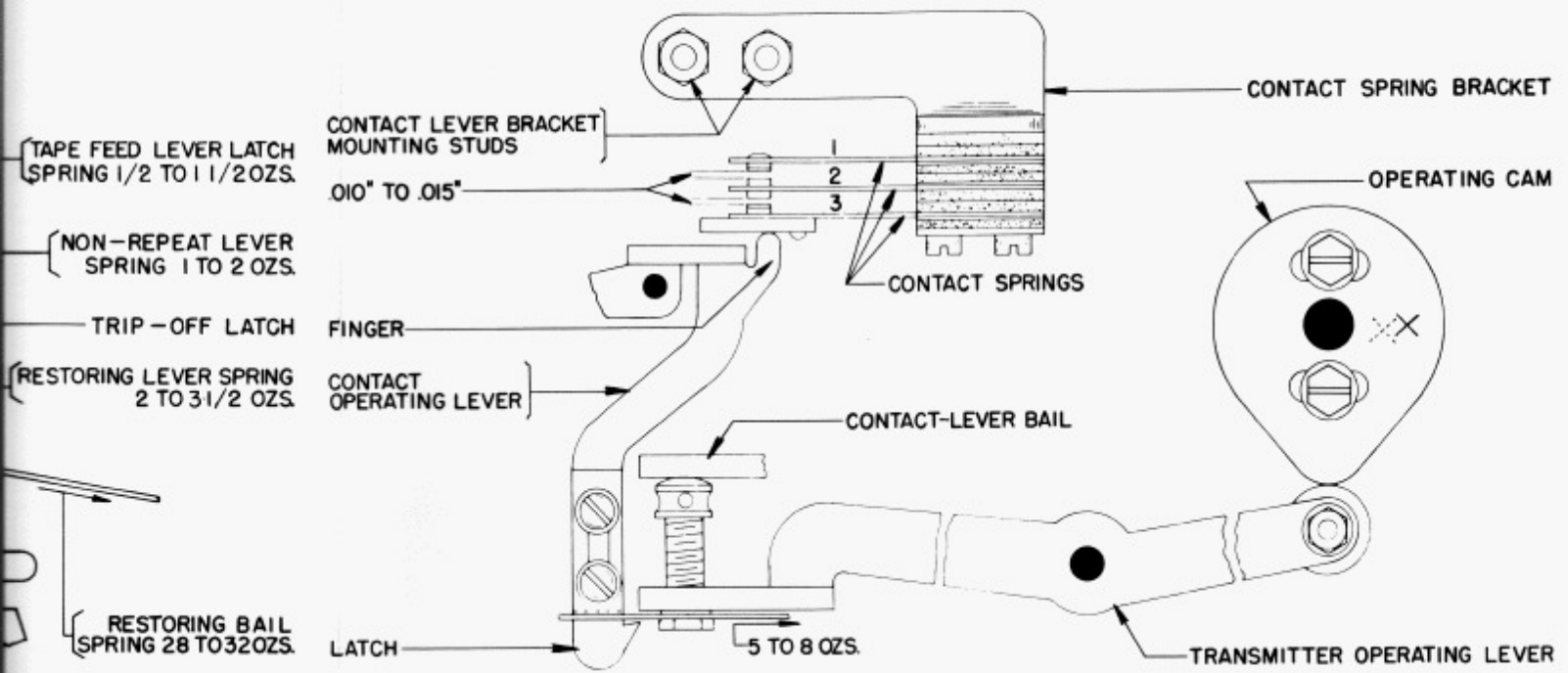

FIGURE 76

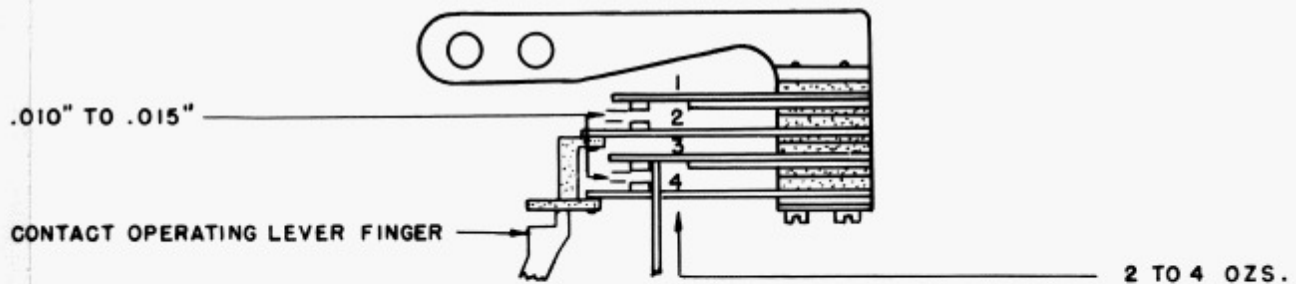
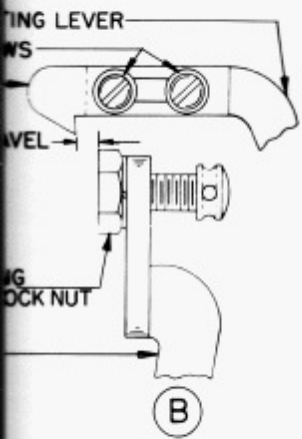

FIGURE 77

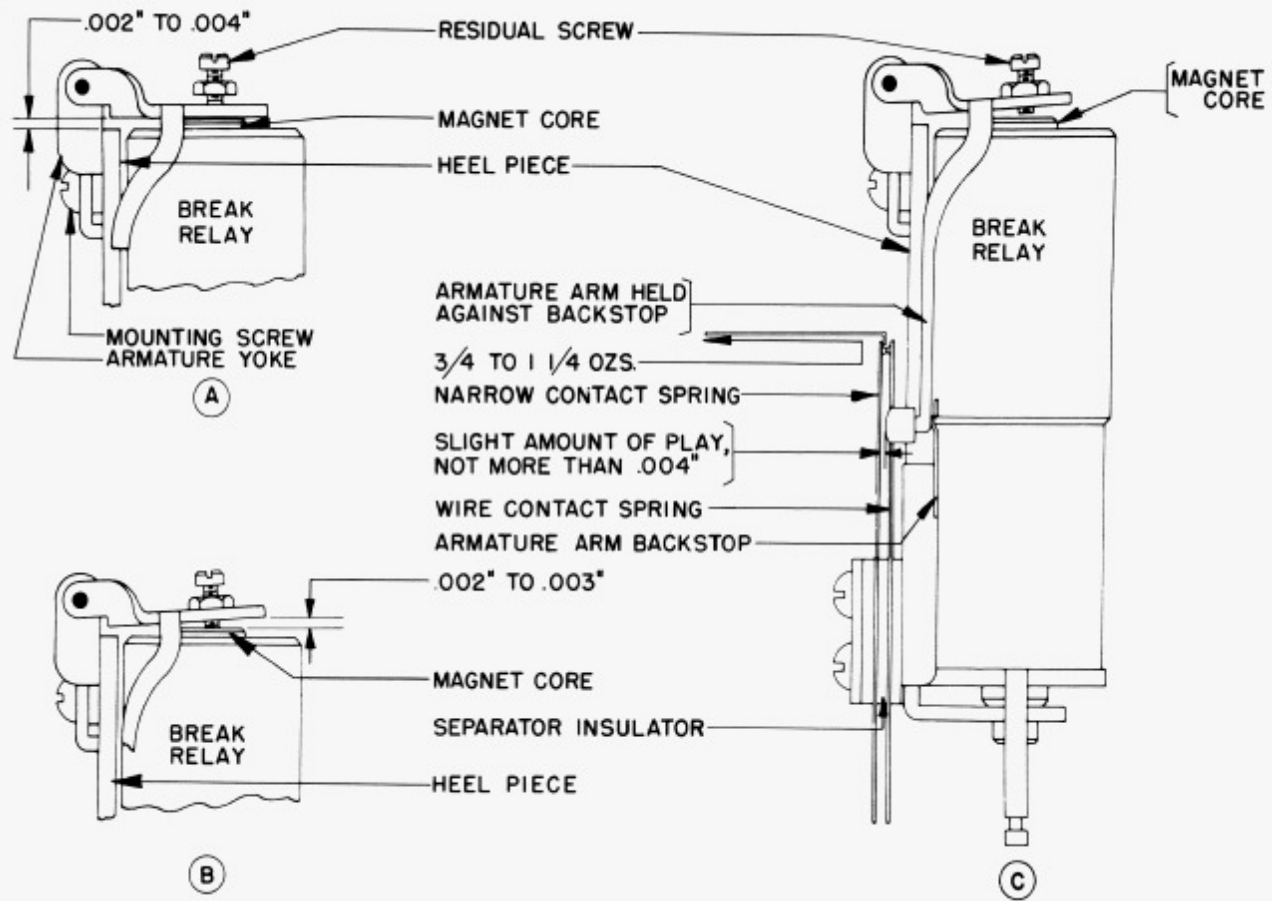

FIGURE 78

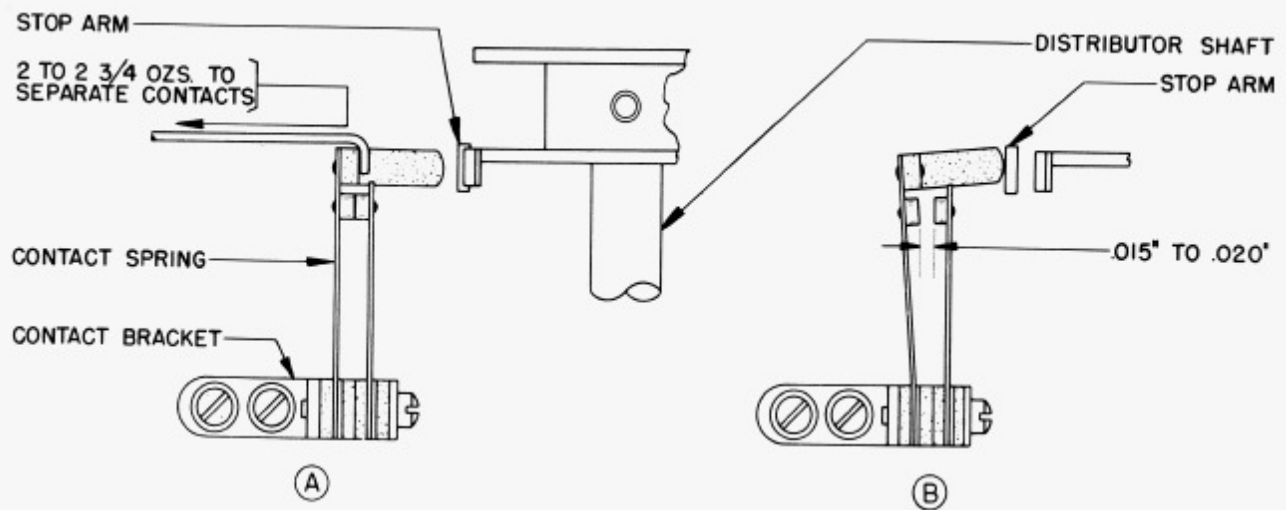

FIGURE 79

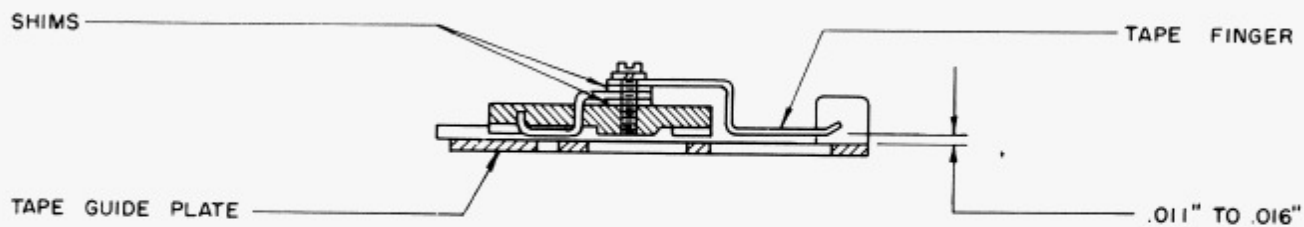

FIGURE 80

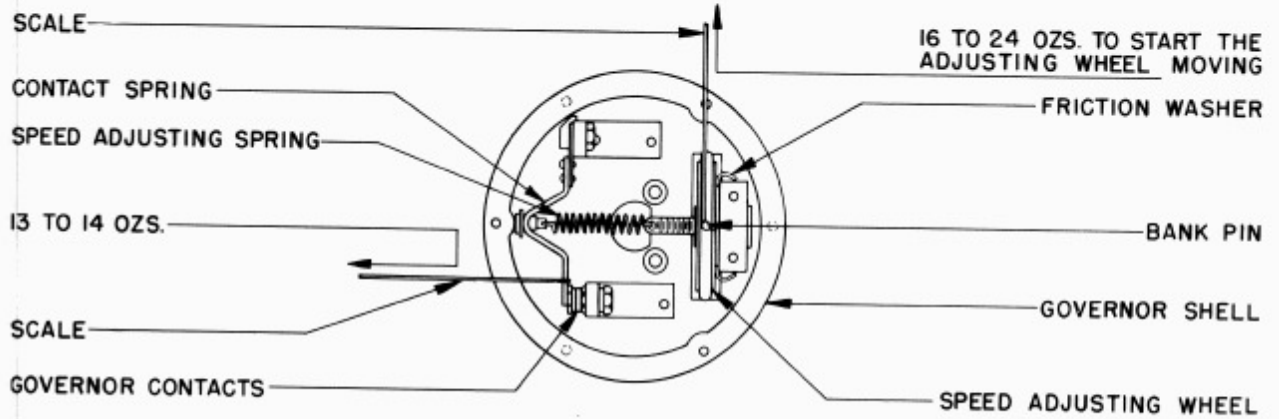
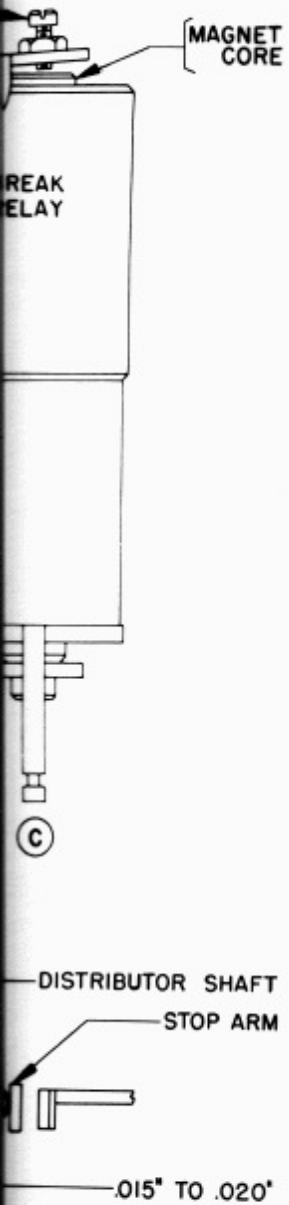

FIGURE 81

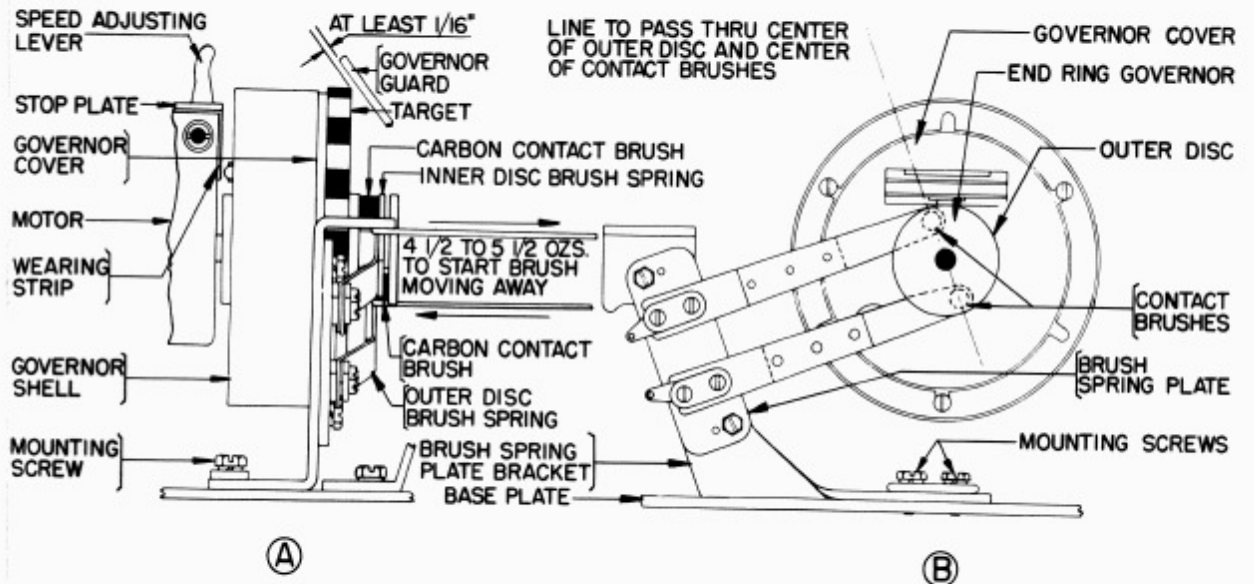

FIGURE 82

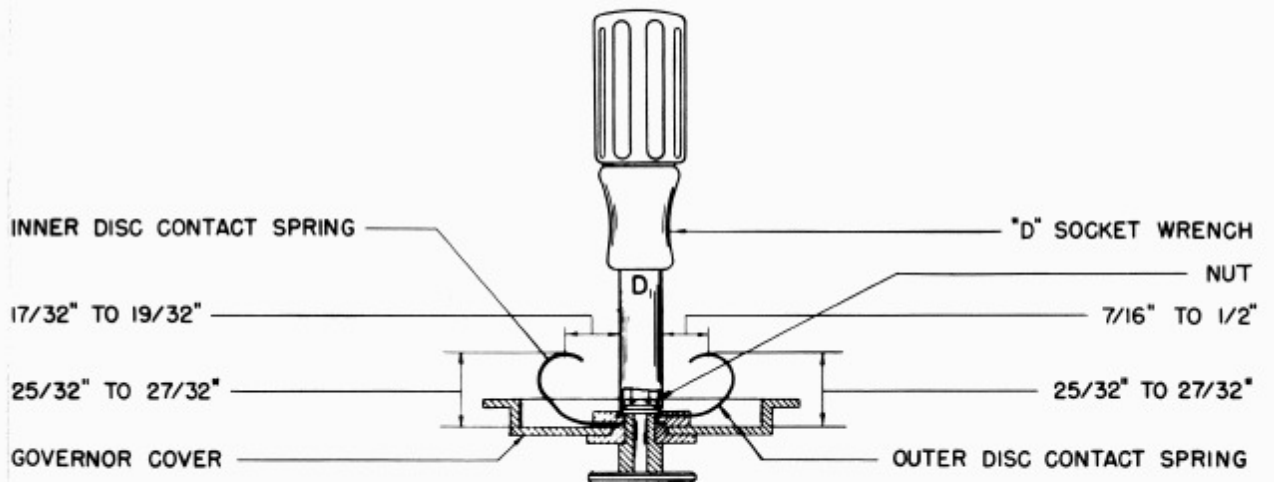

FIGURE 83

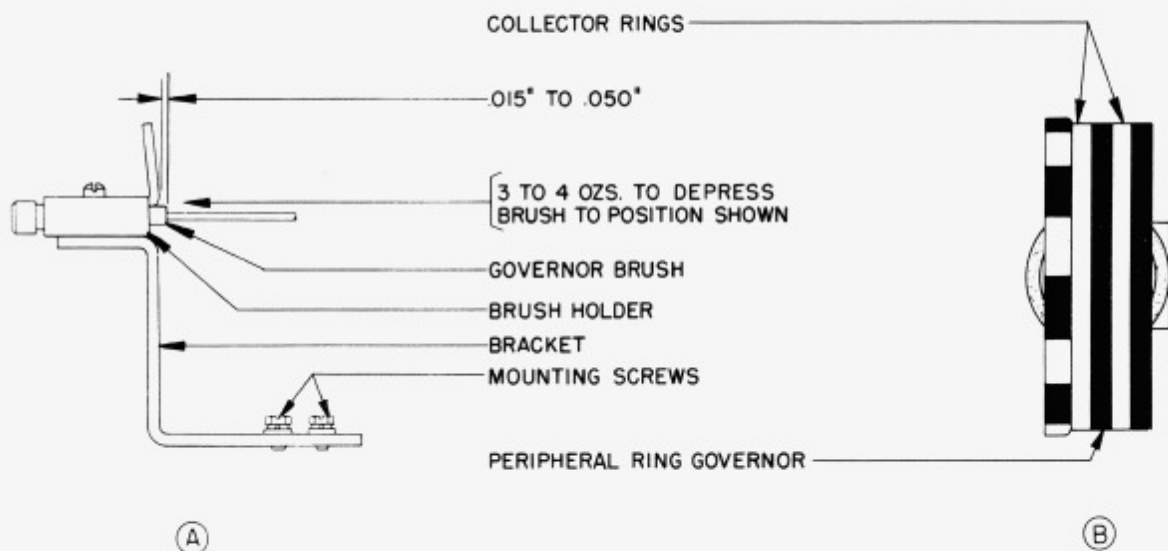

FIGURE 84

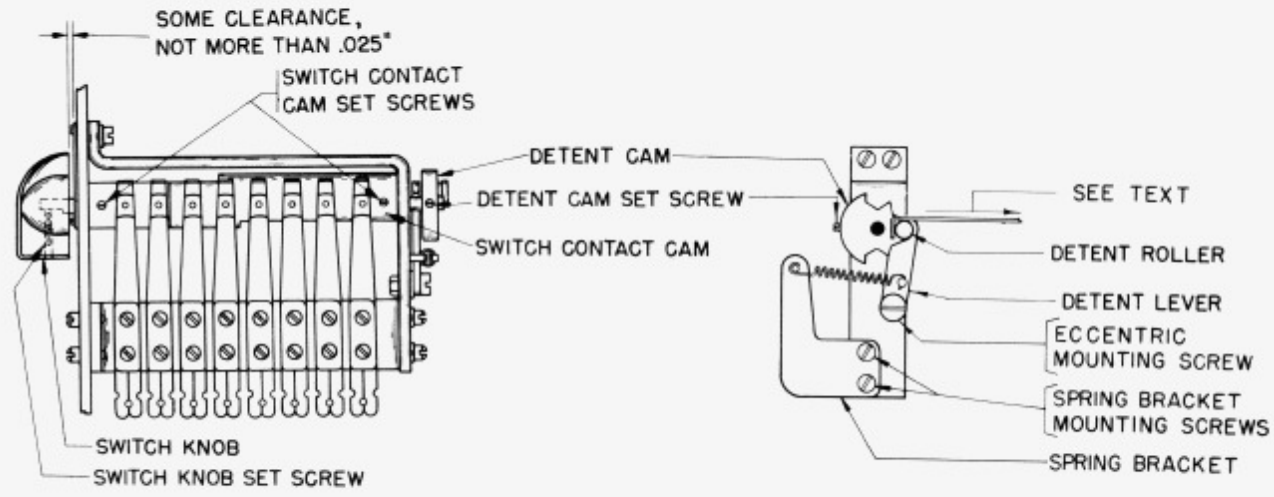

FIGURE 85

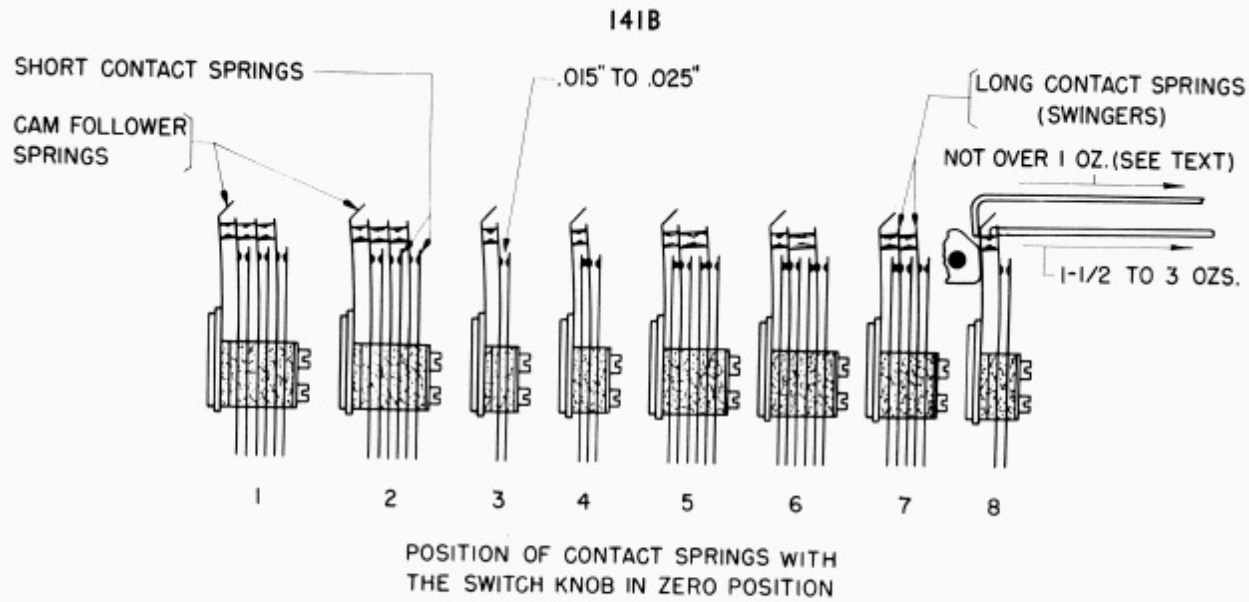

FIGURE 86

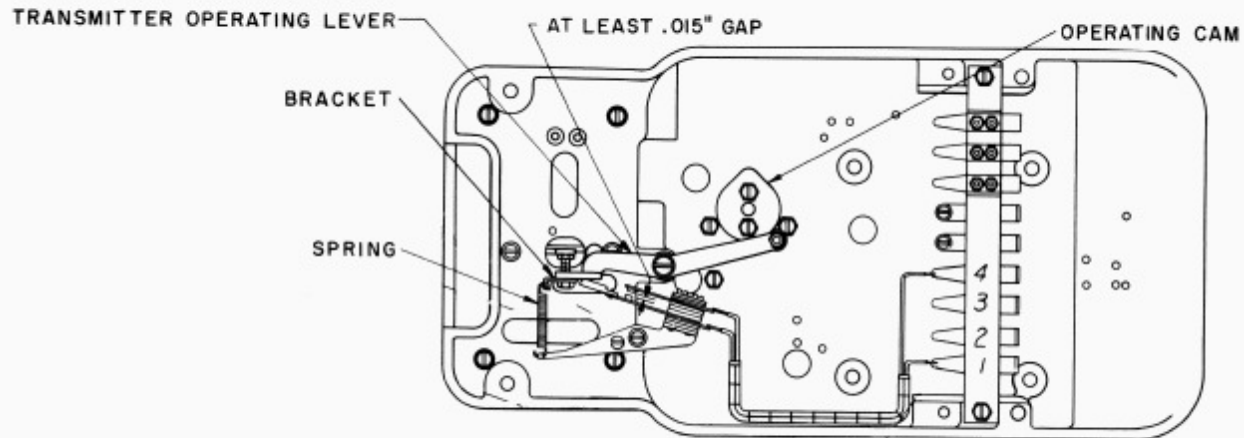

FIGURE 87

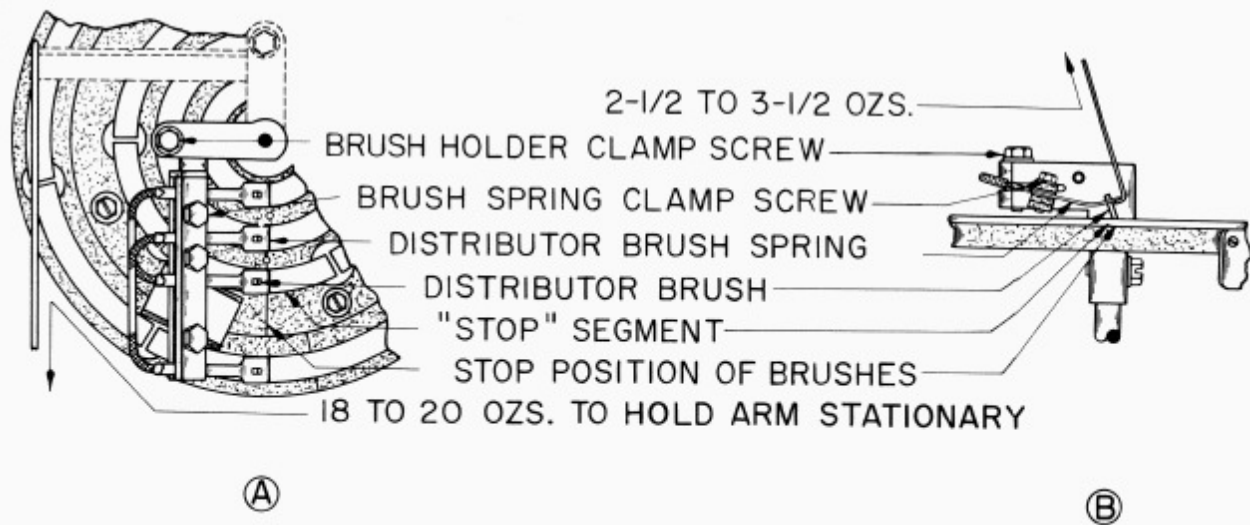

FIGURE 88